

TUTORIEL : BASE ROULANTE DU ROBOT 2010



Réalisé par la *PERRIN'S TEAM*

<http://www.perrinsteam.fr>

Grâce à ce tutoriel, vous pourrez réaliser la partie droite de la base motrice du robot 2010 de la Perrin's Team qui participera à la Coupe de France de Robotique. Il vous sera aisé de réaliser la base motrice entière.

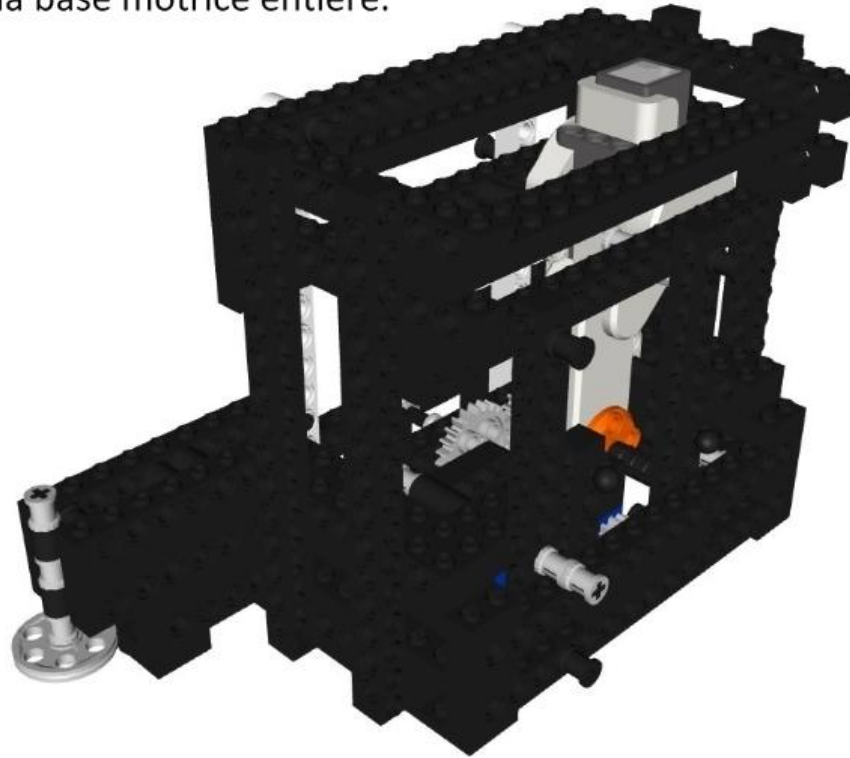

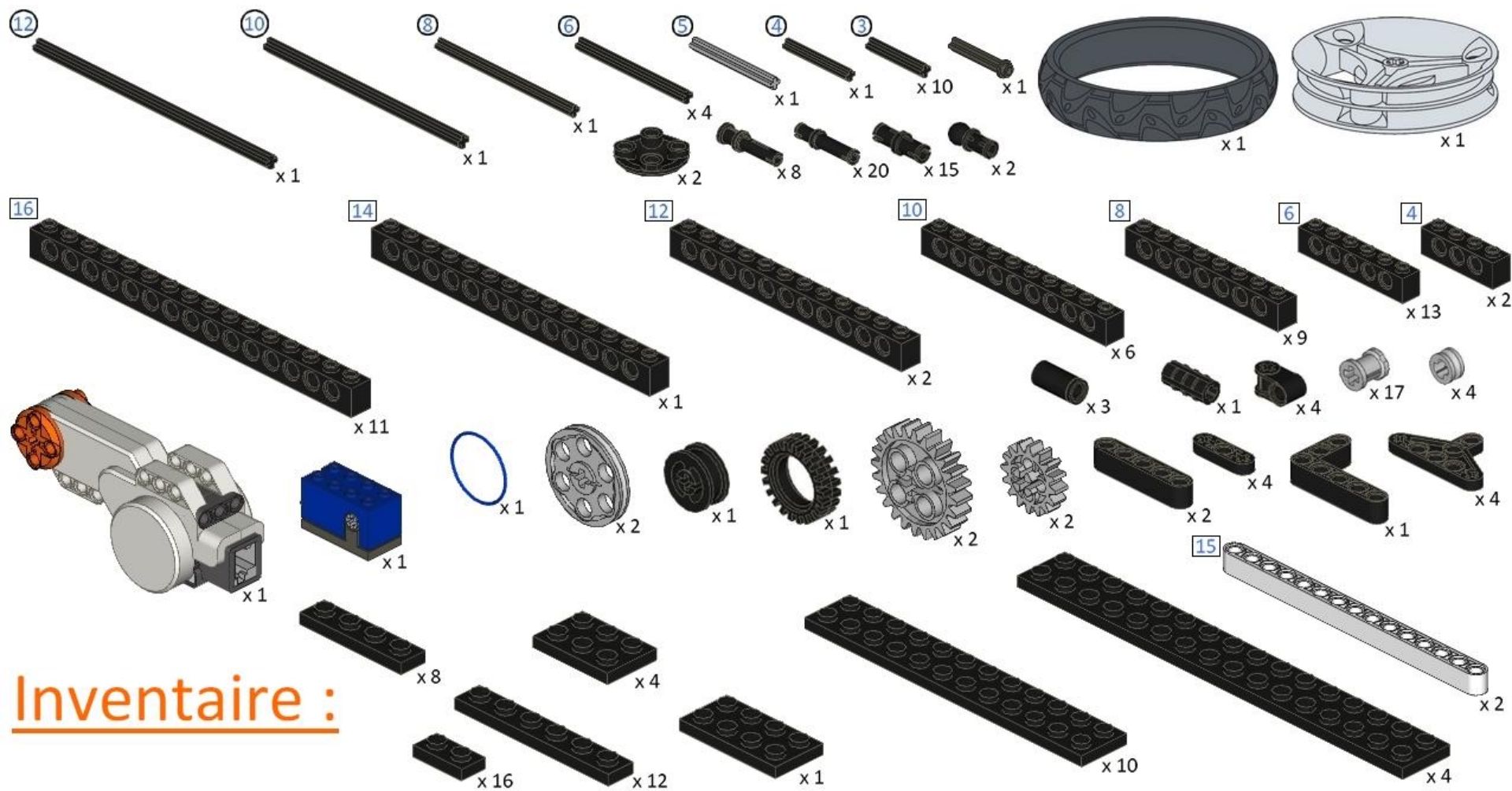

Inventaire :

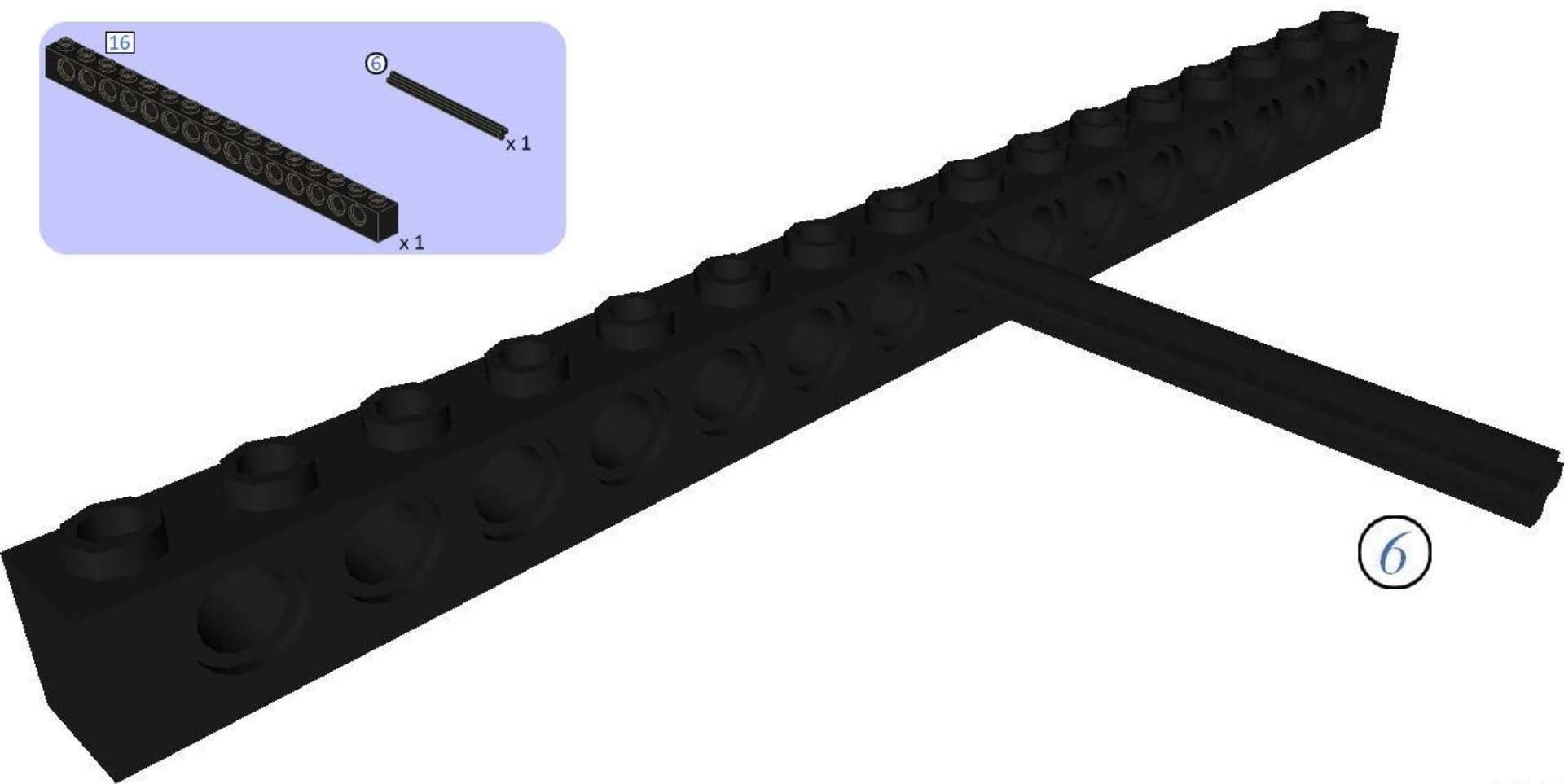
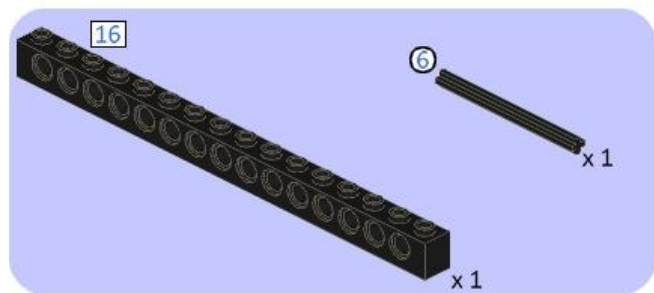



Mettre la roue et le pneu entre les deux rondelles

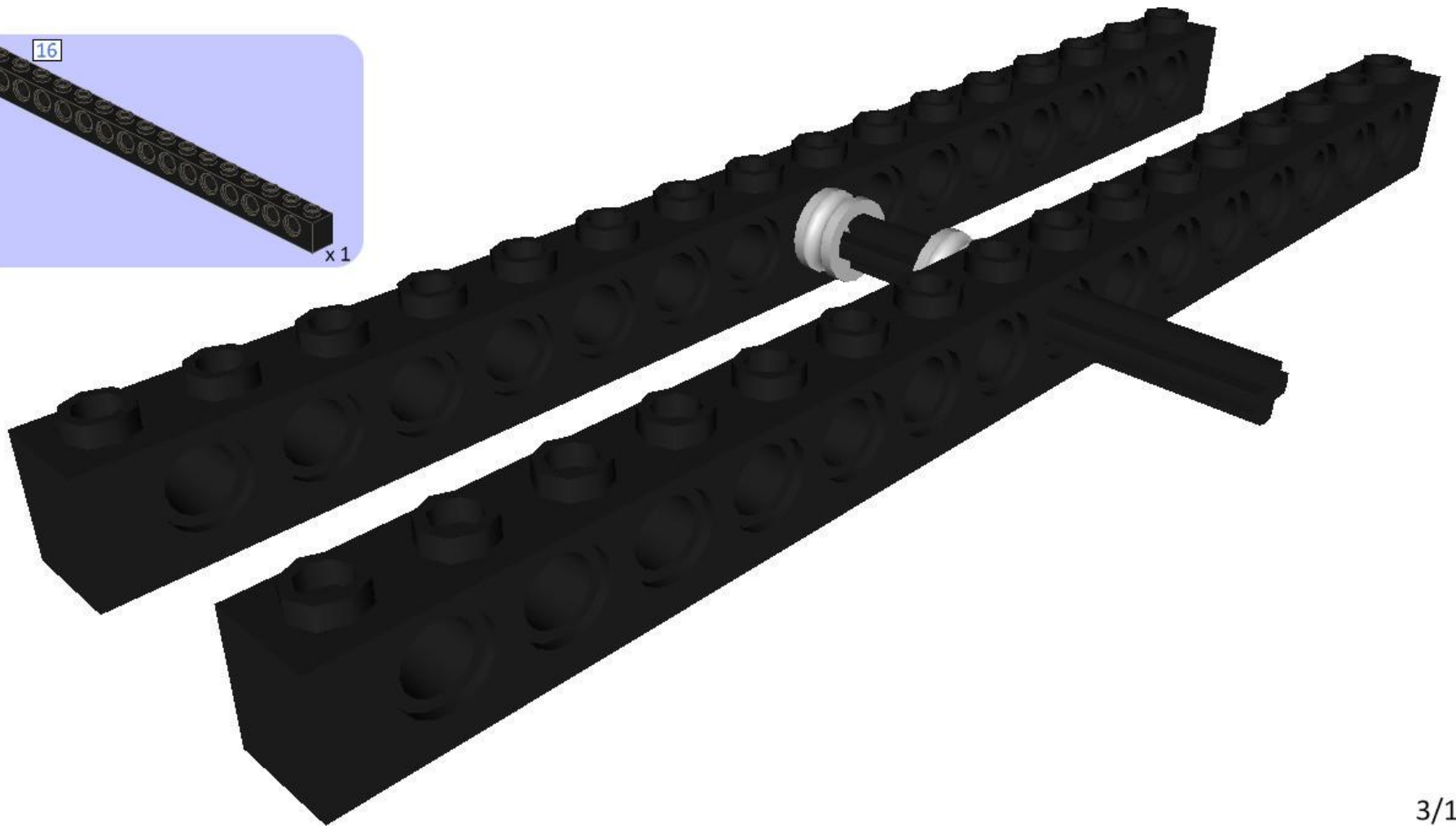
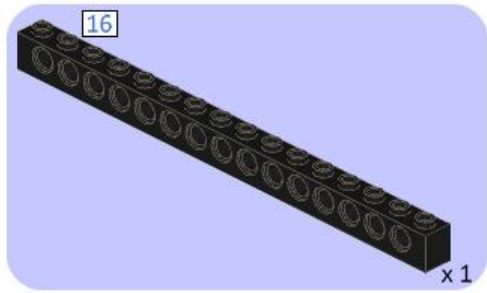

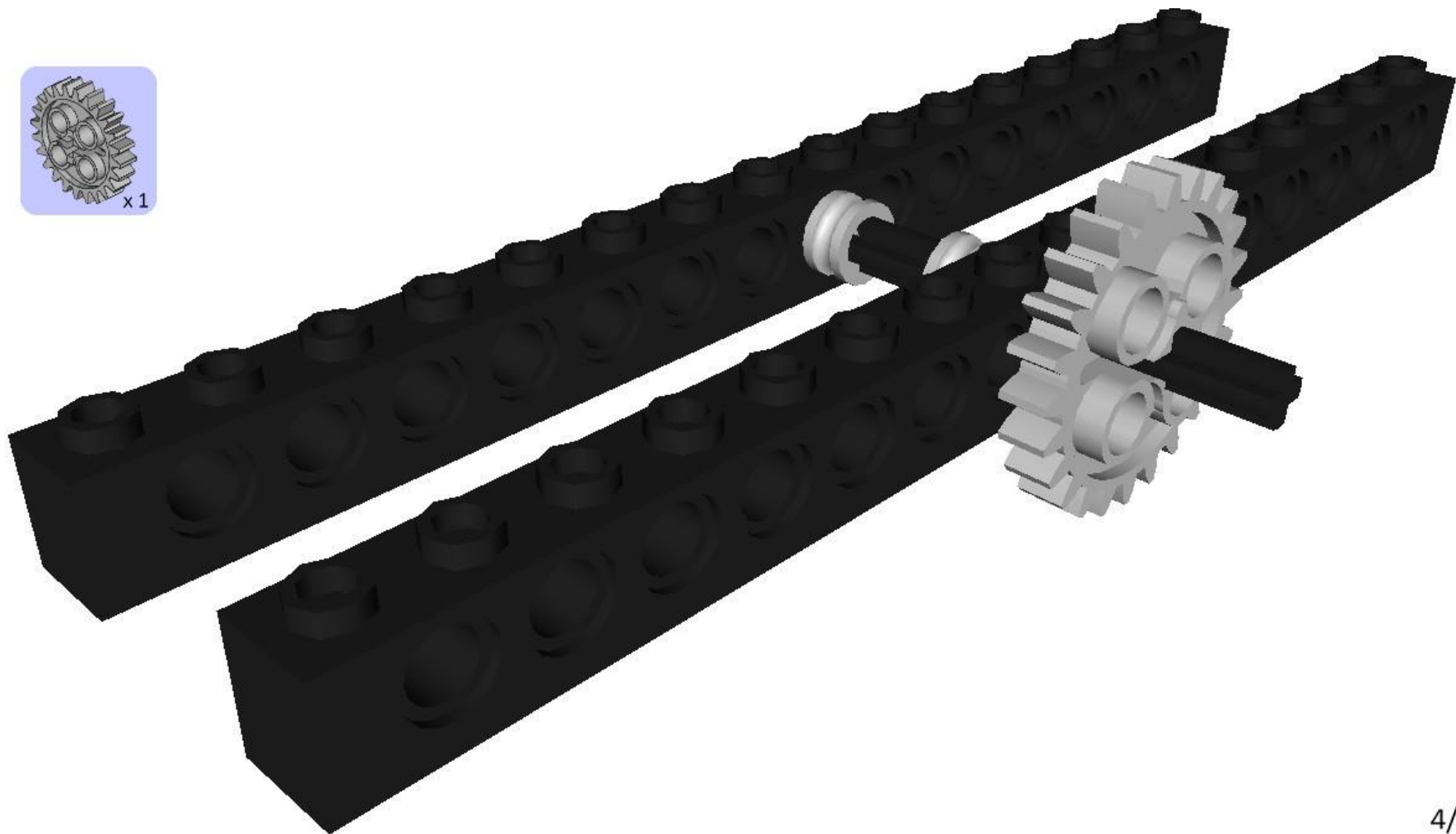

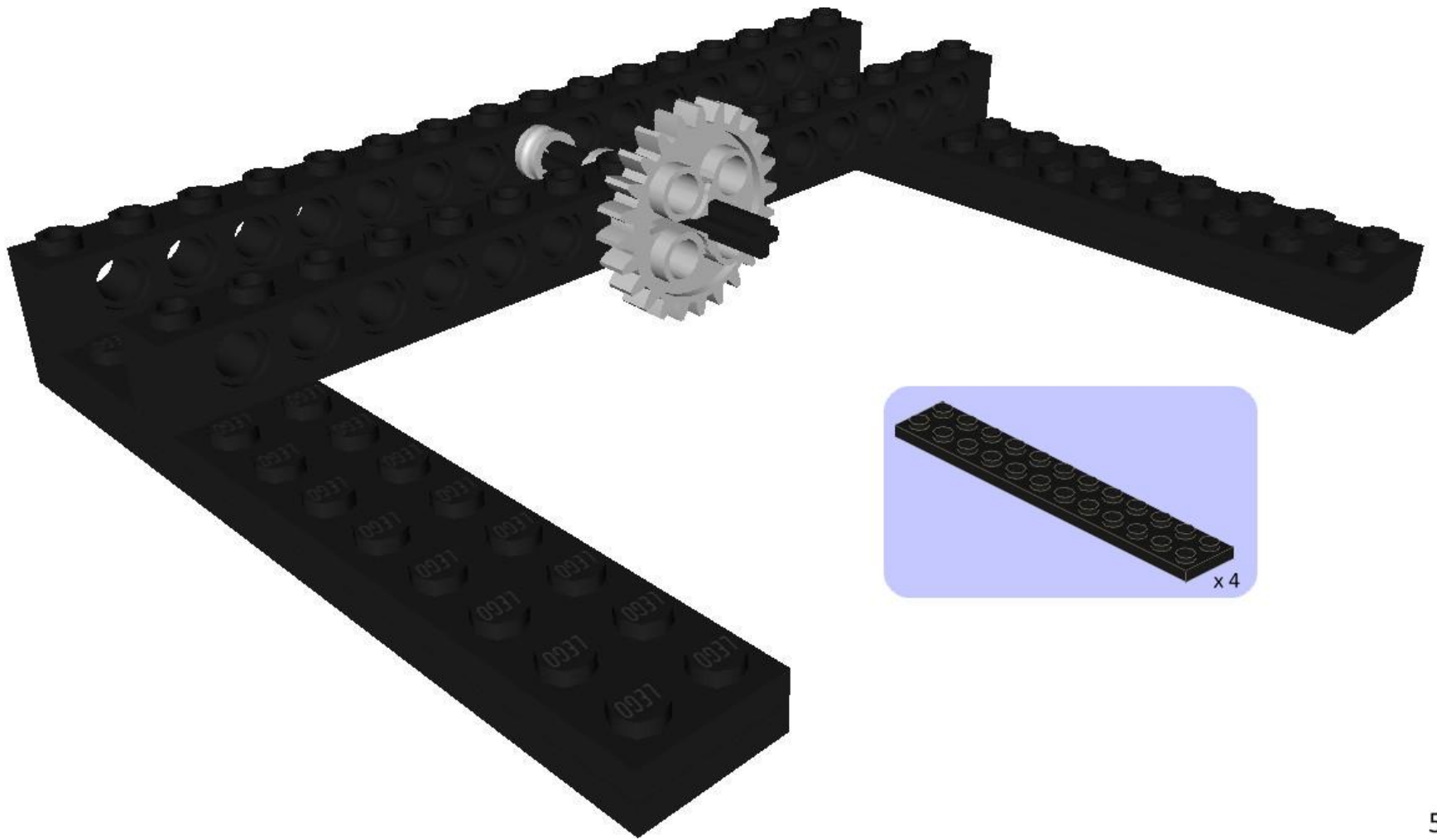

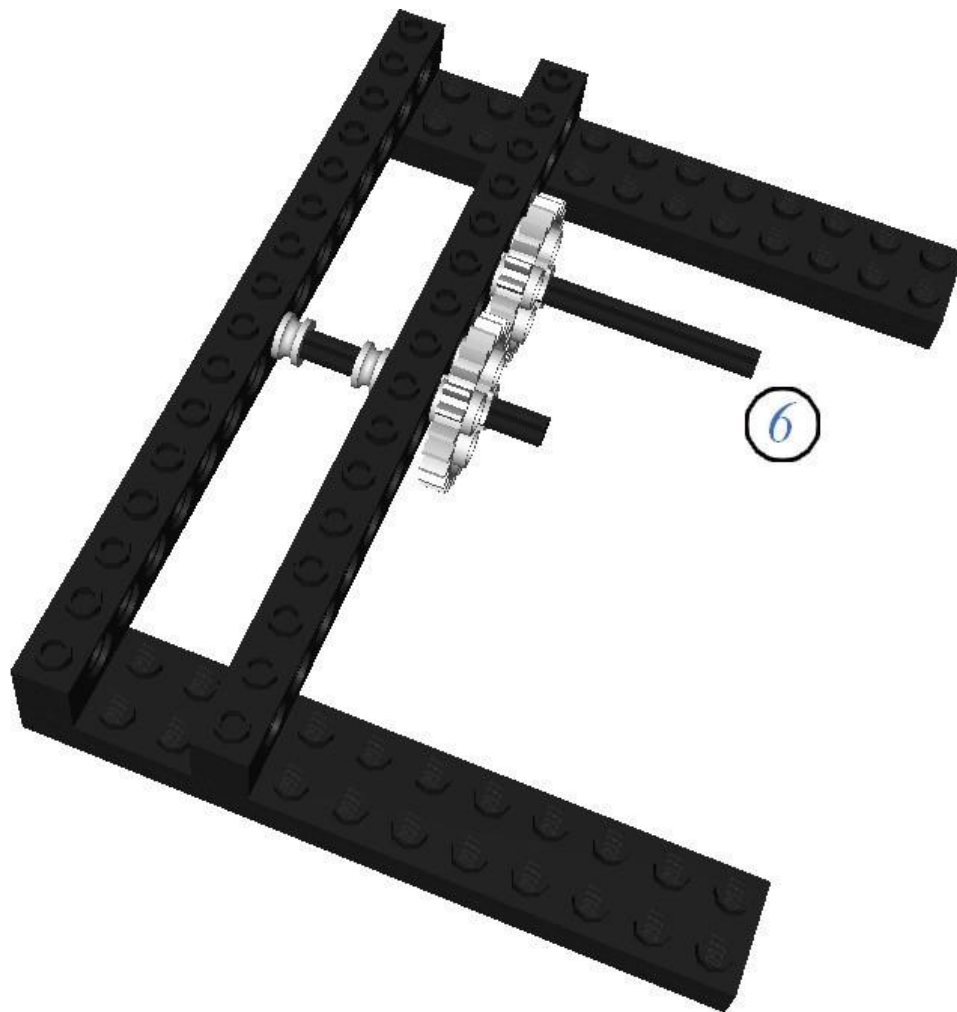
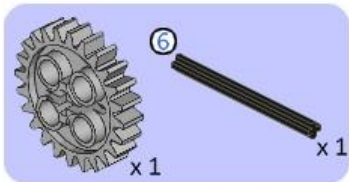

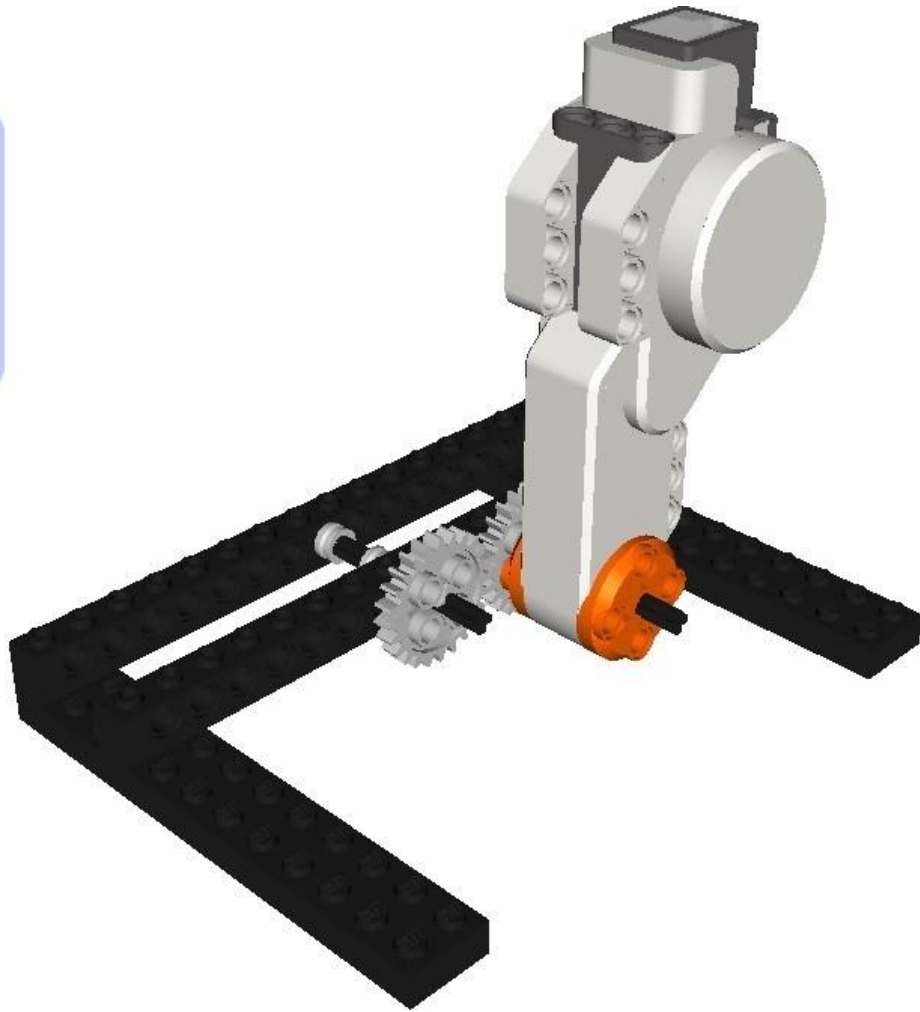
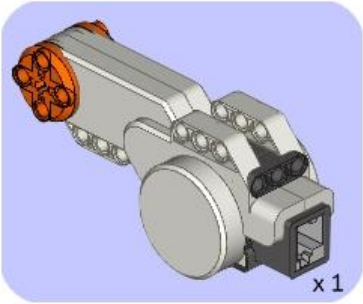

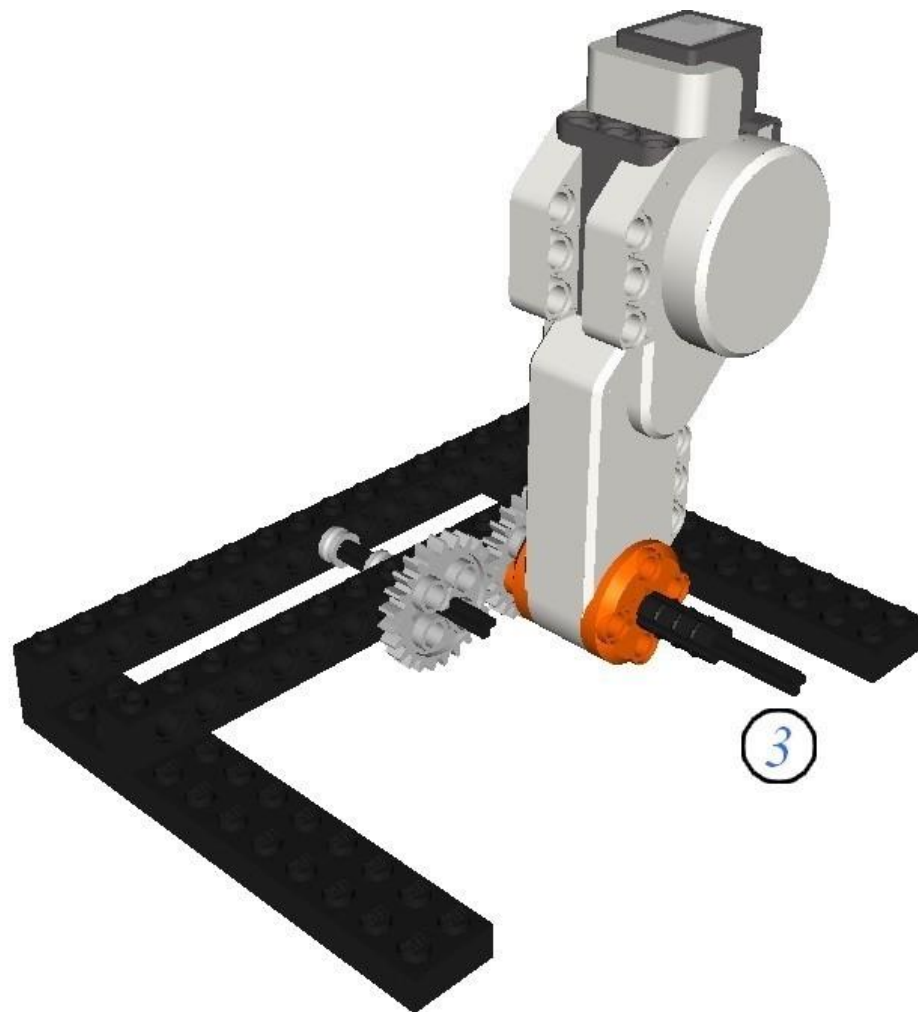

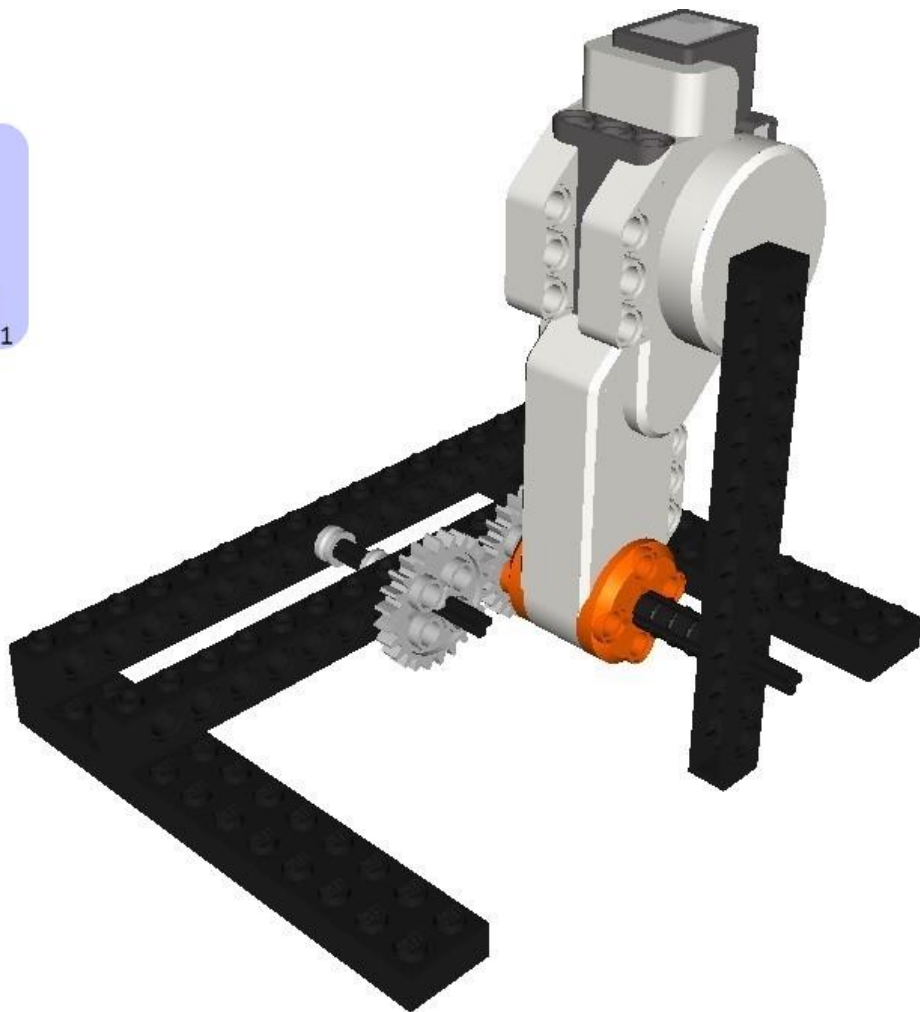
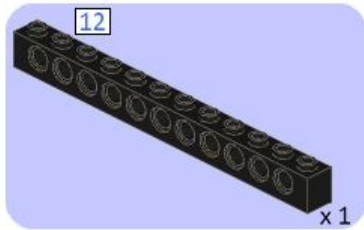

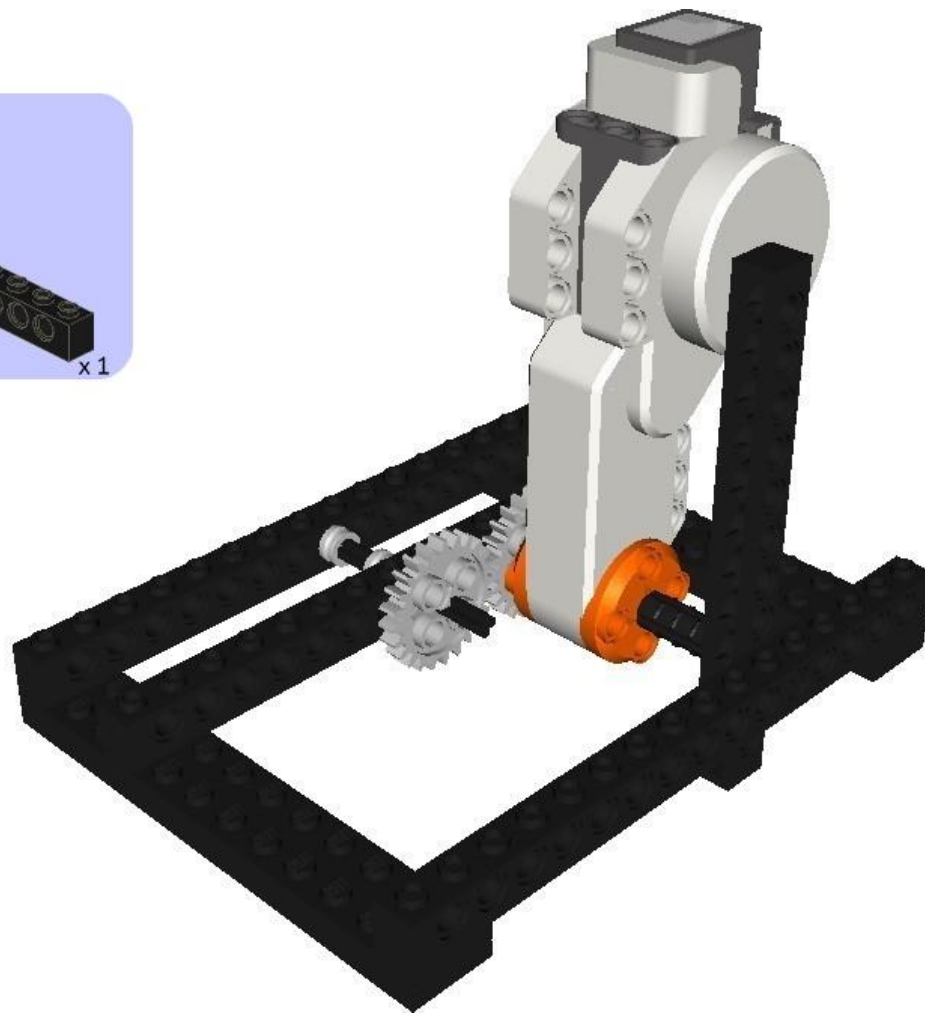
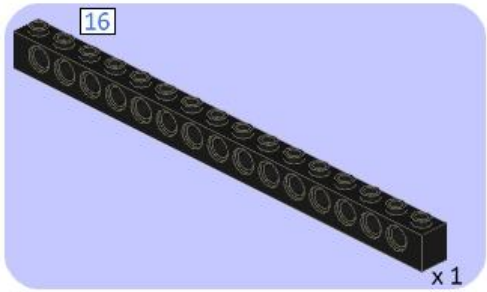

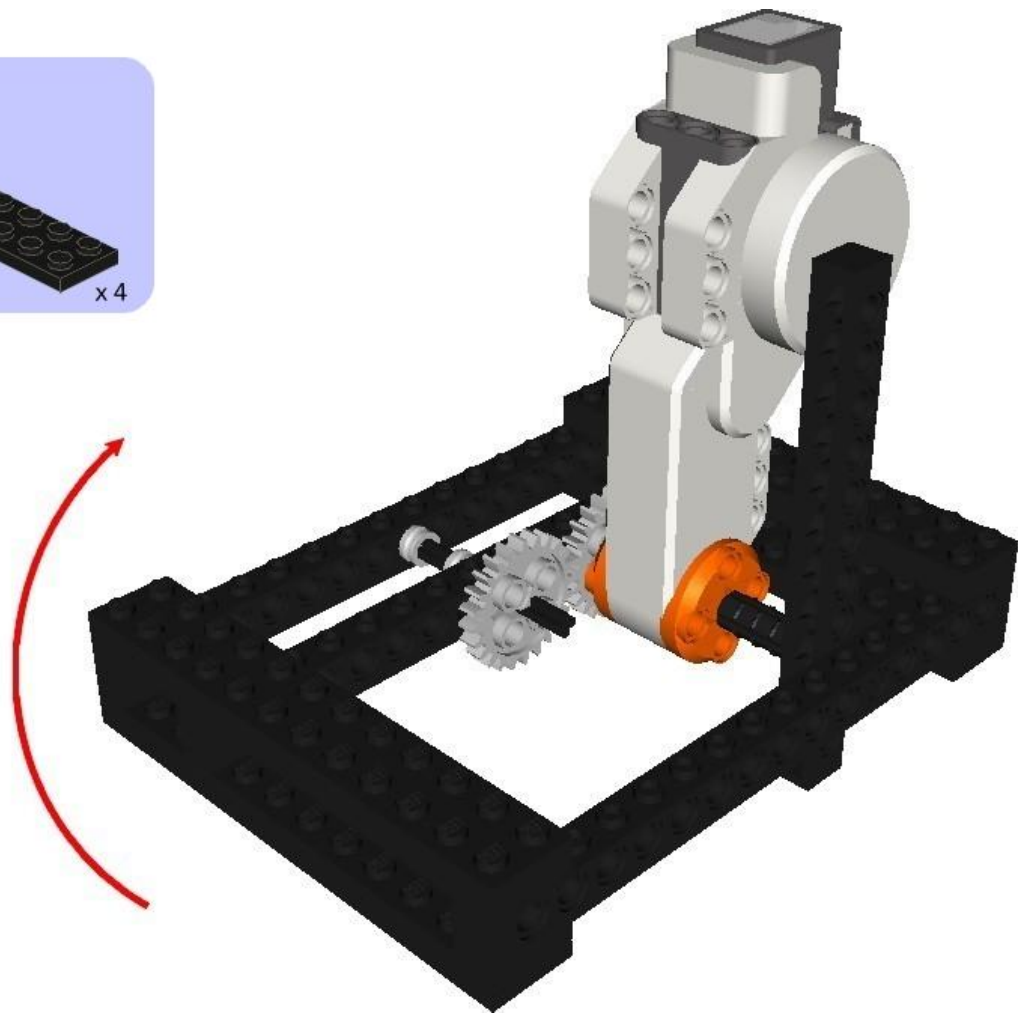
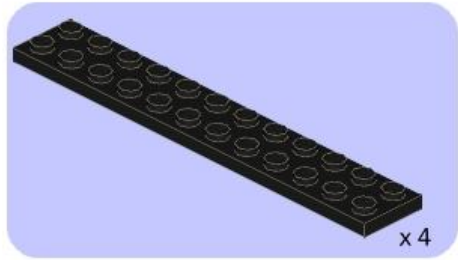

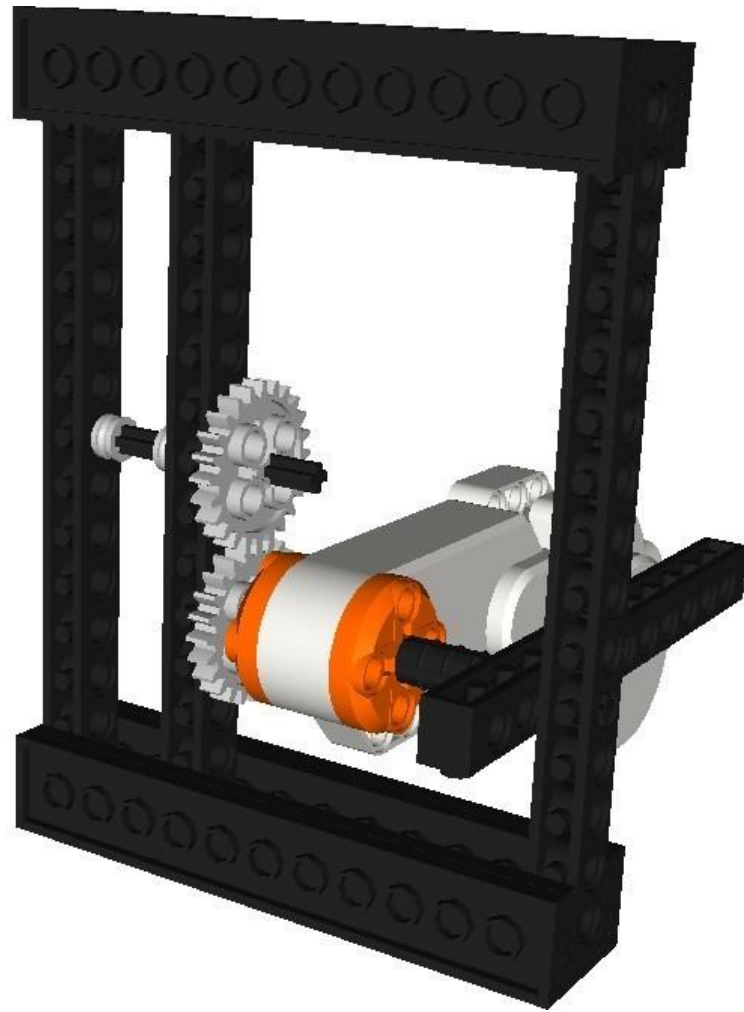

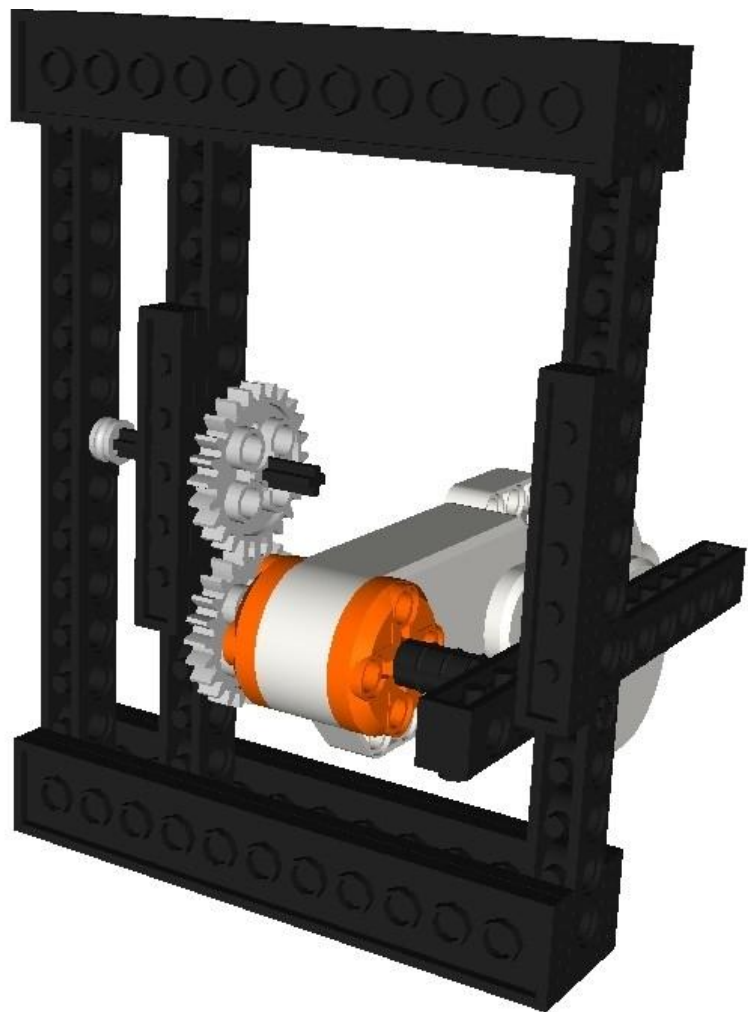

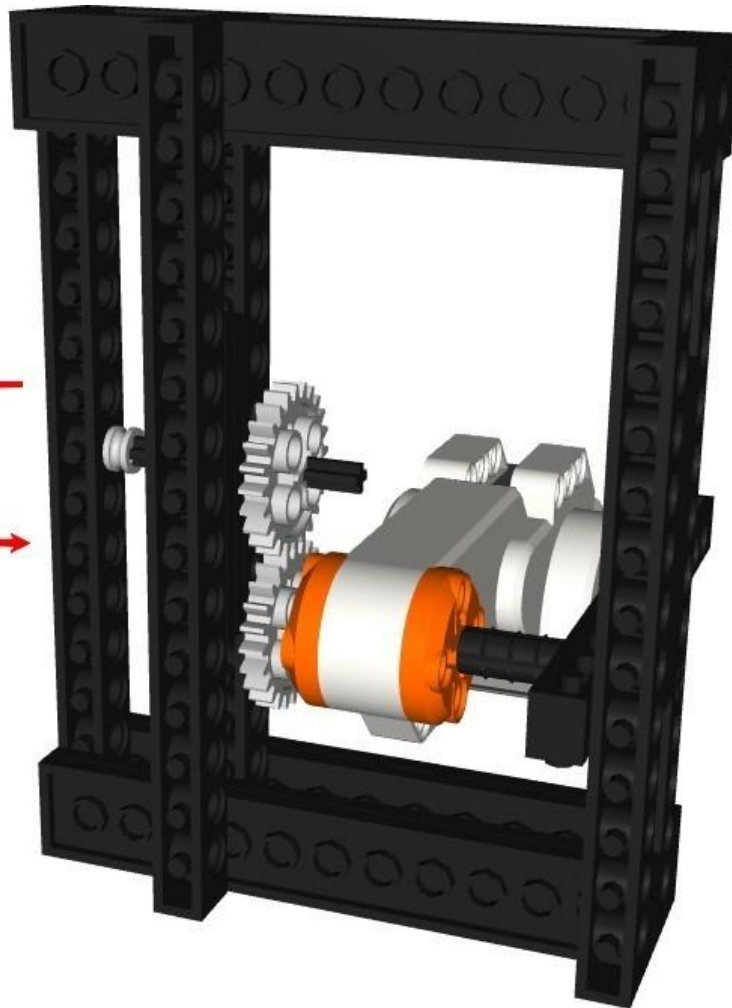
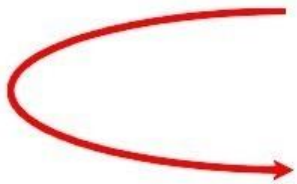
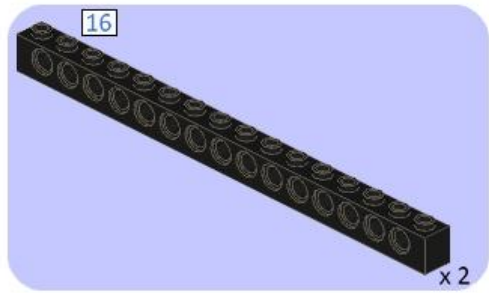

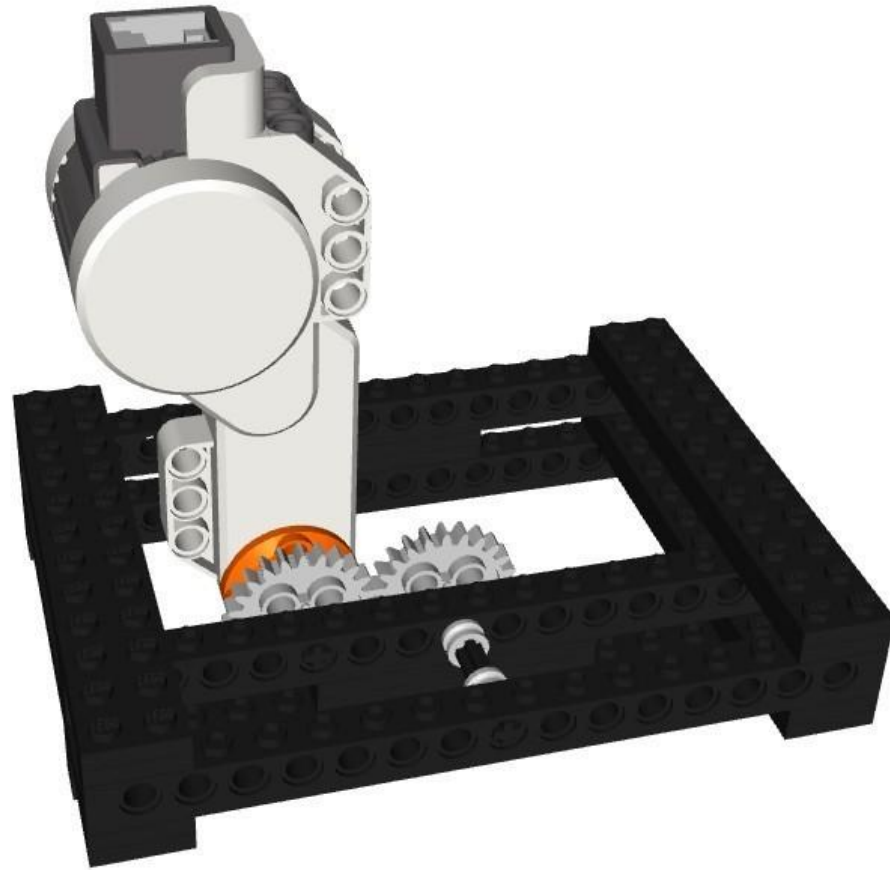

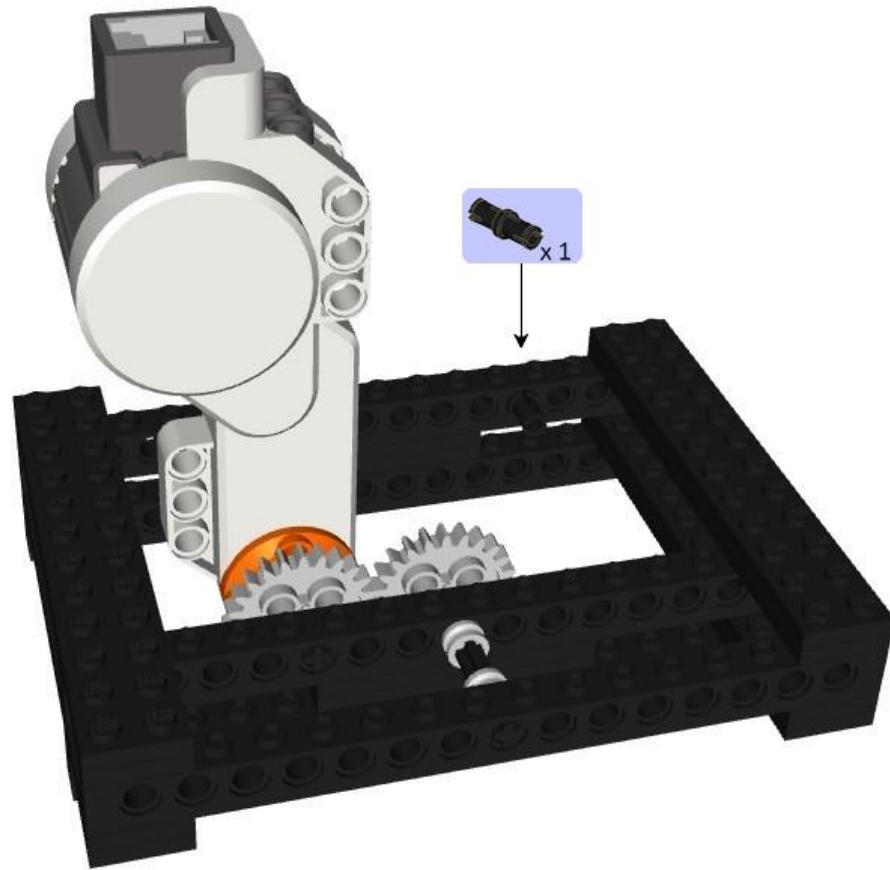

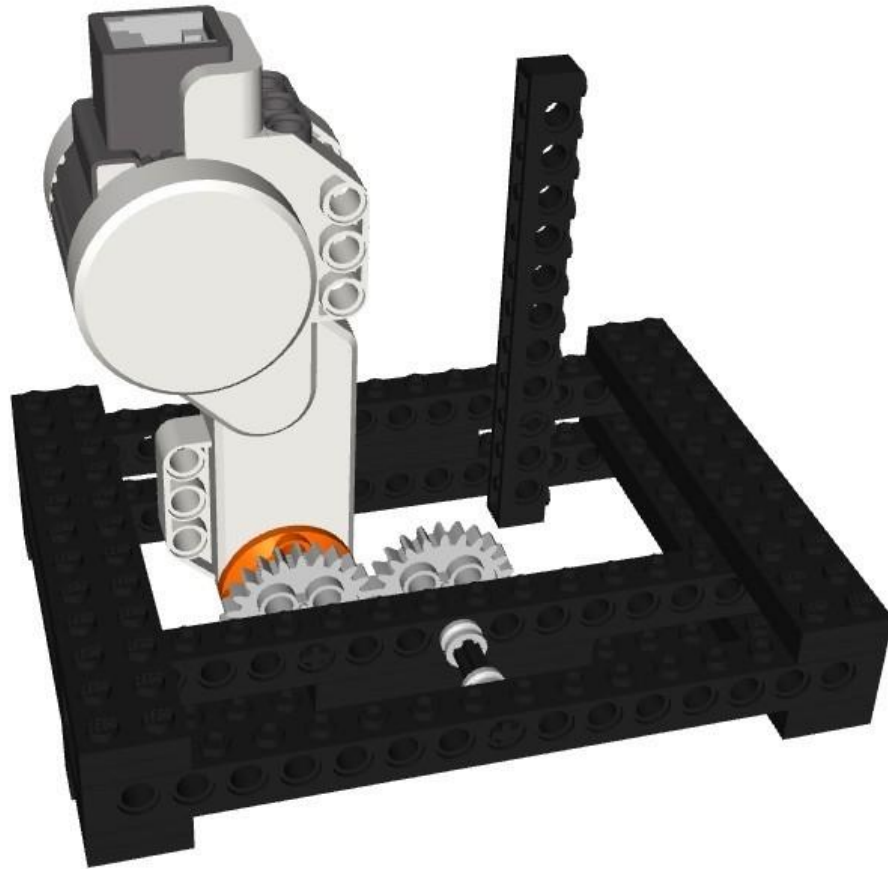
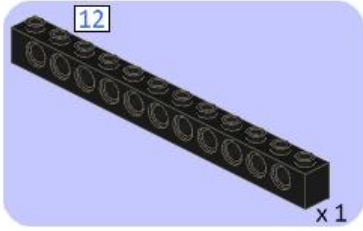

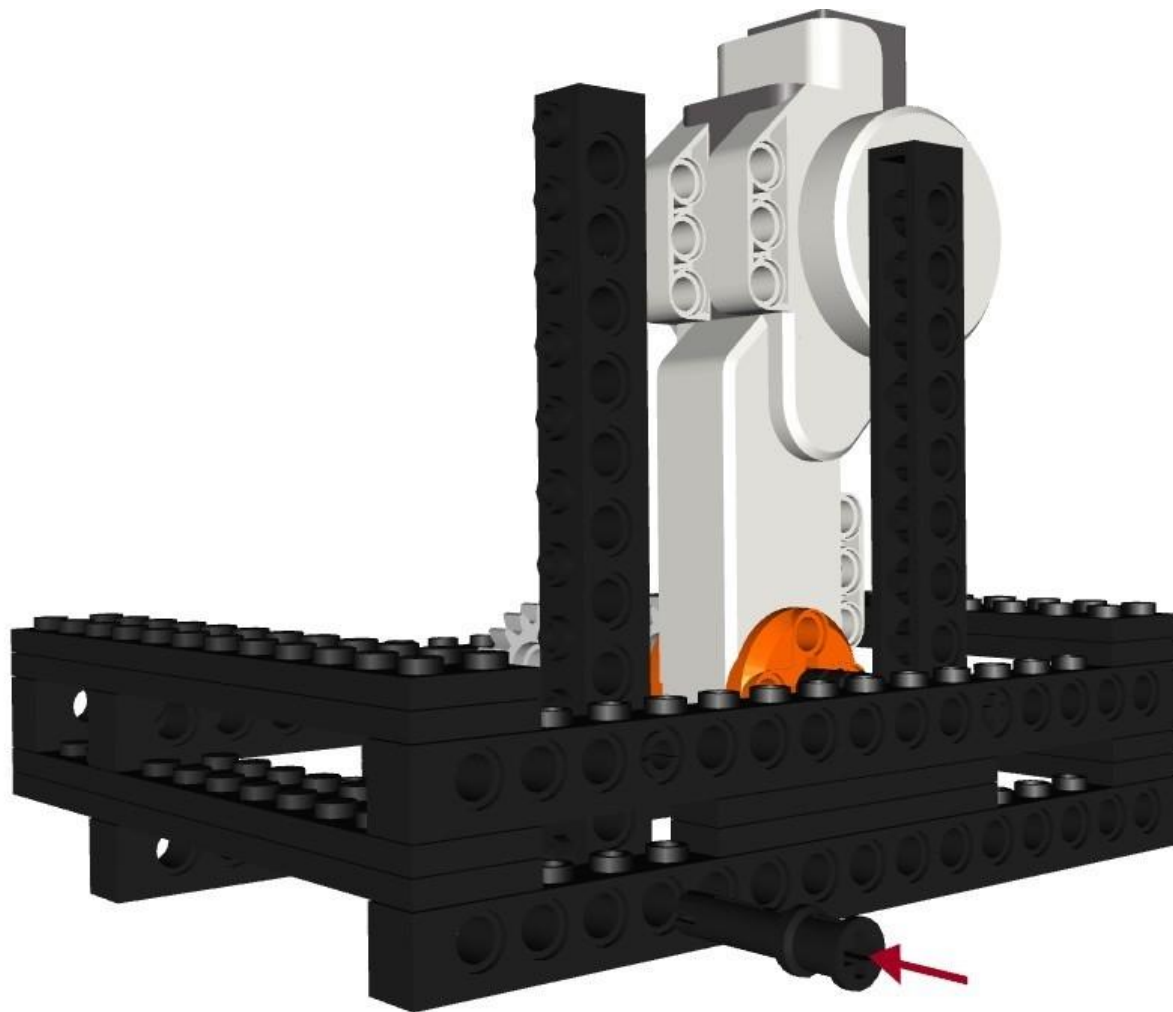

18/147

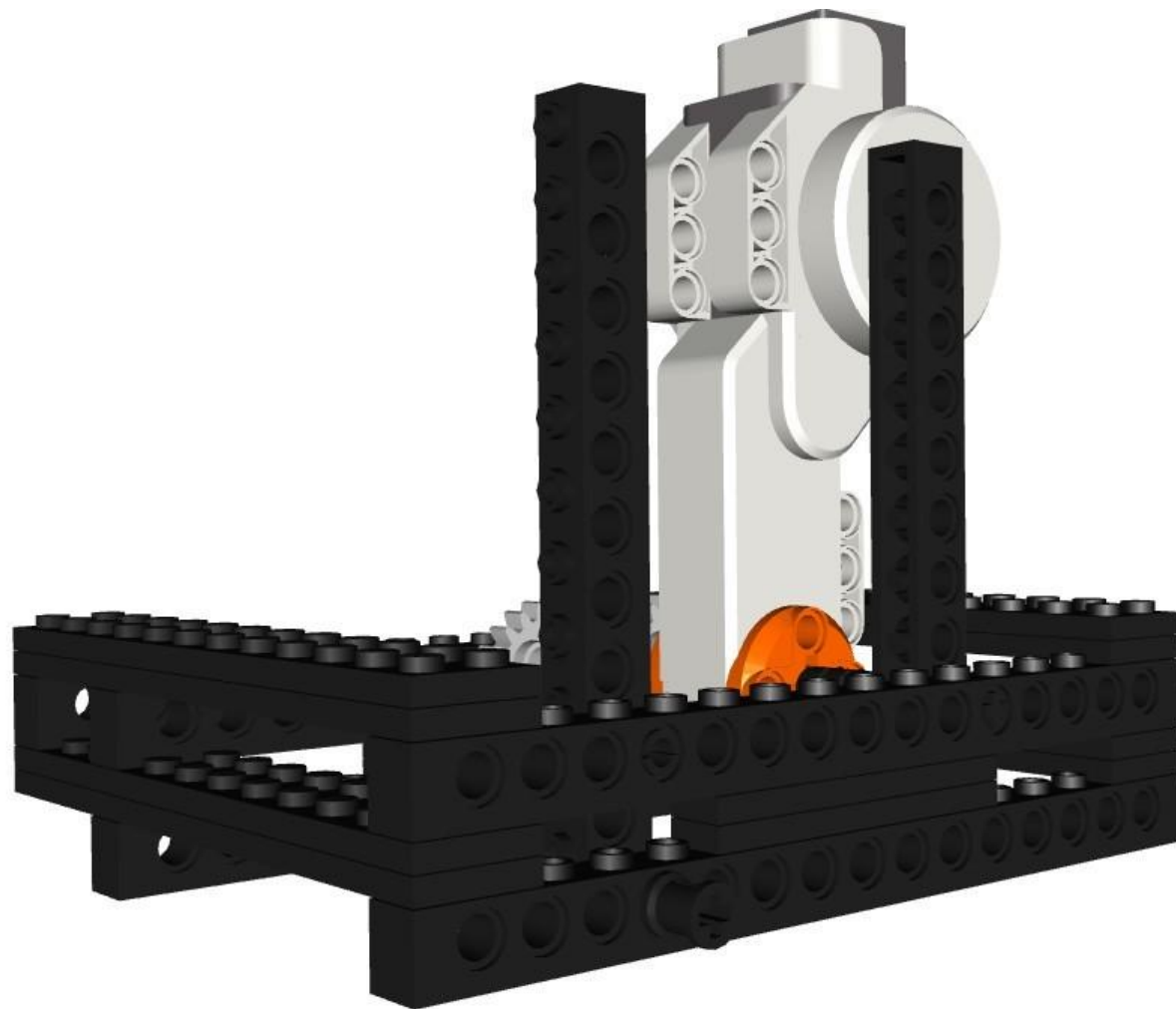

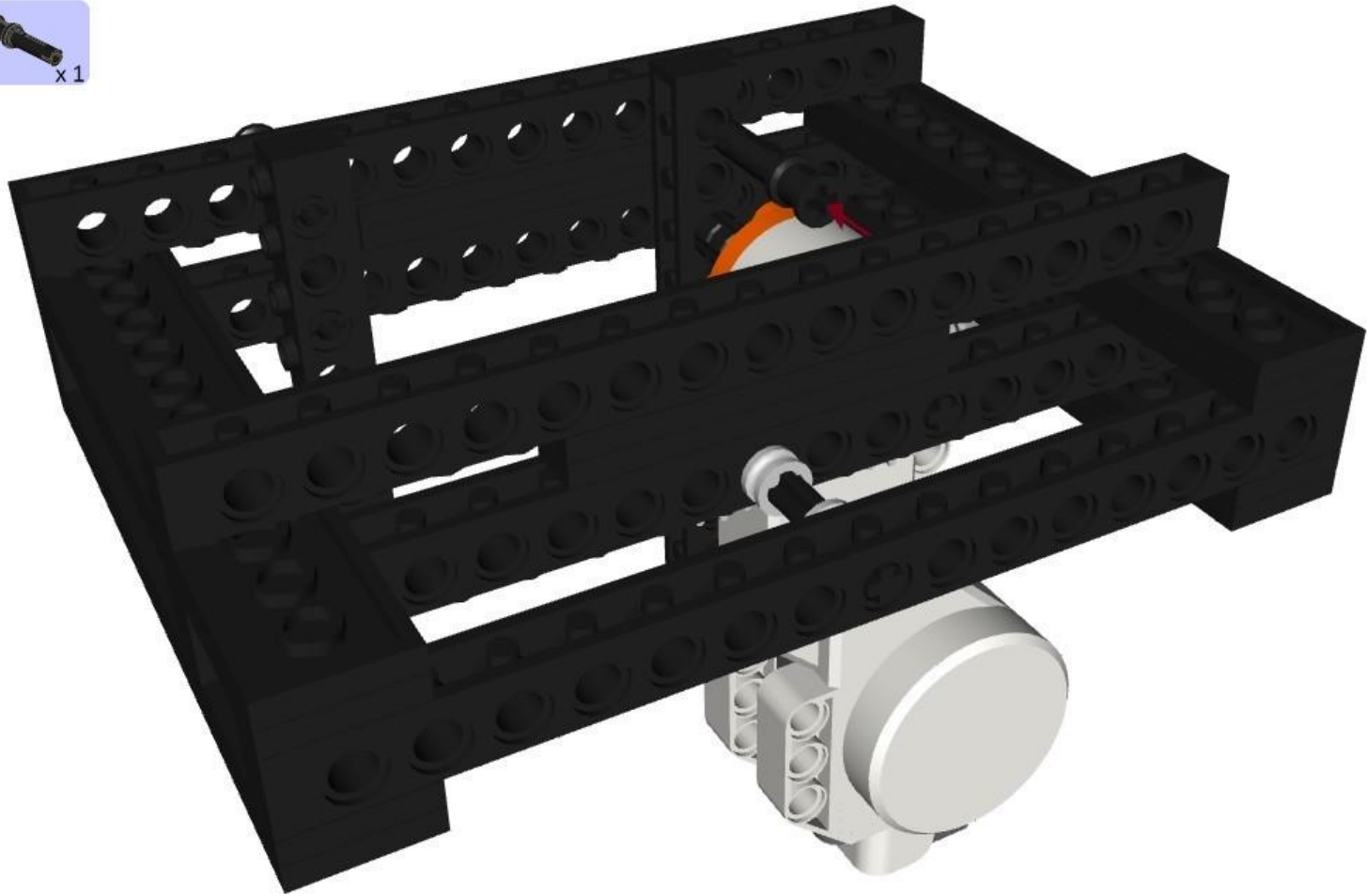

20/147

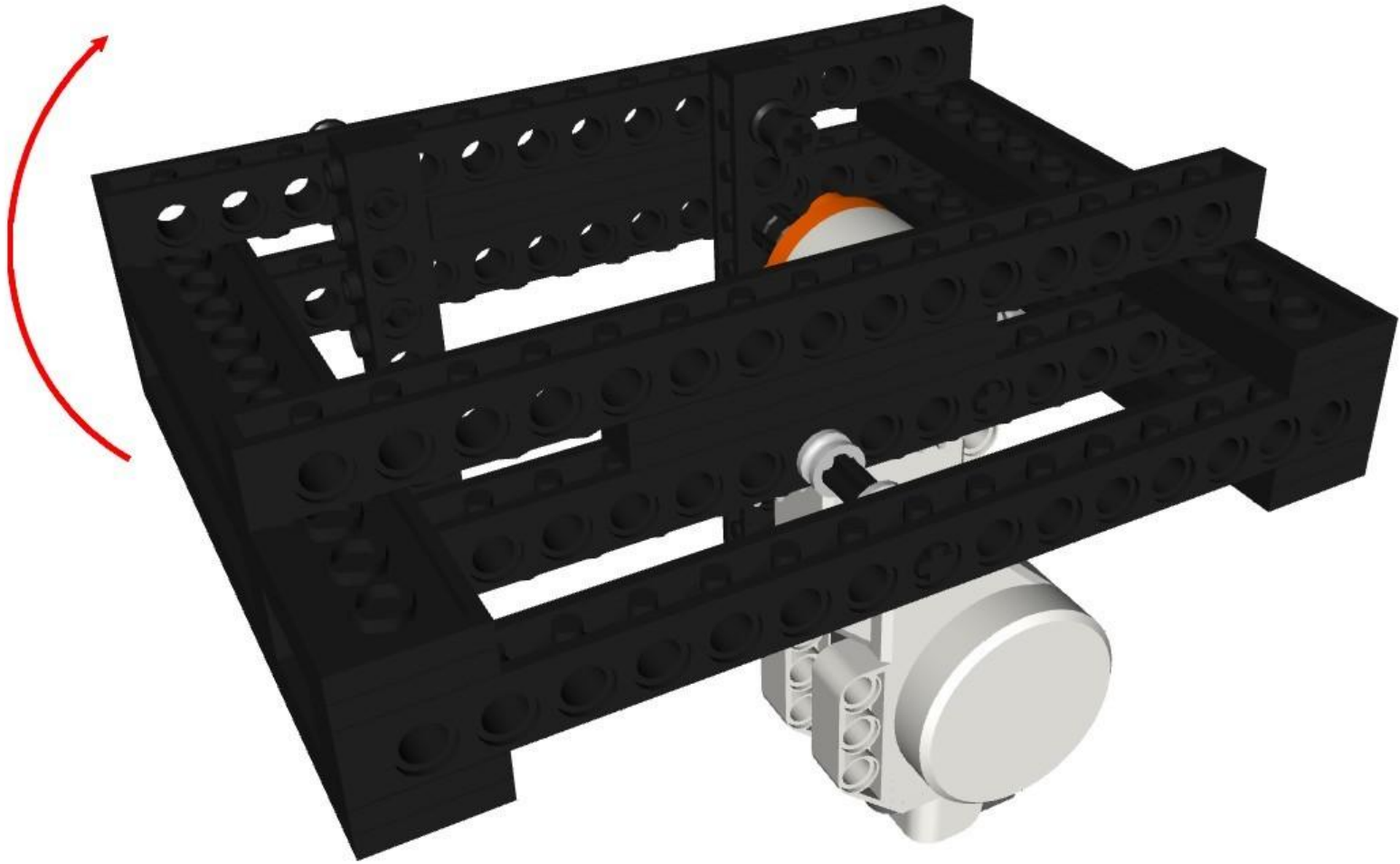

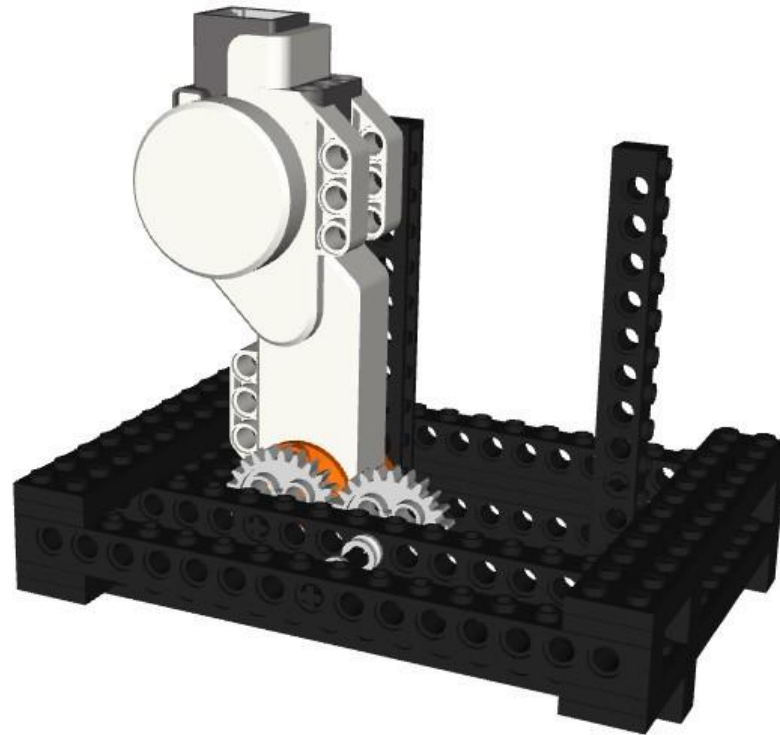

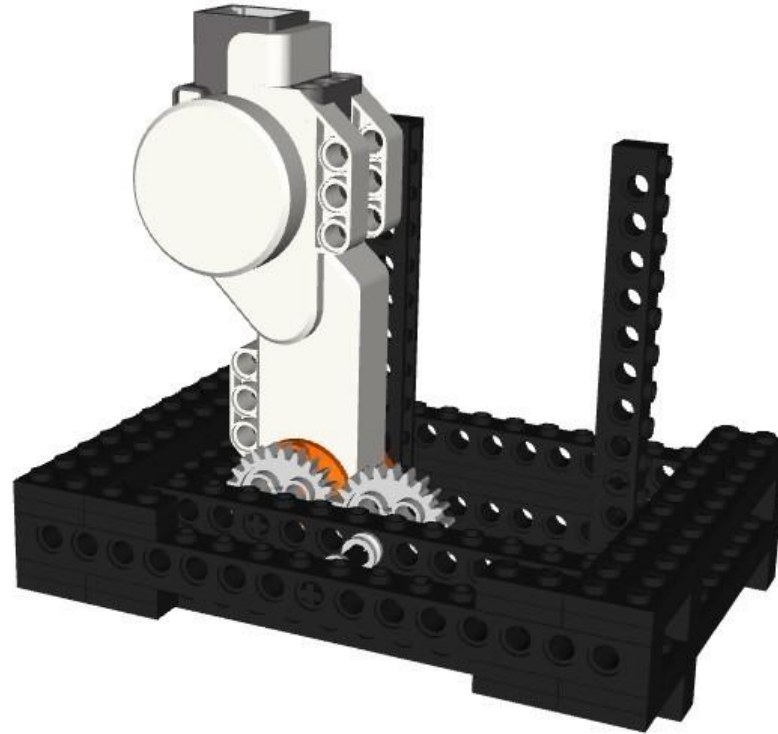
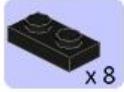

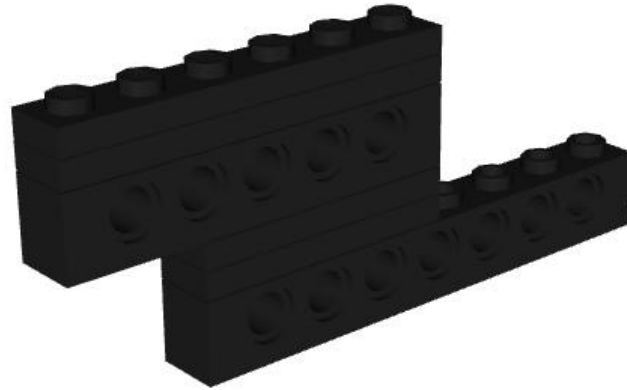
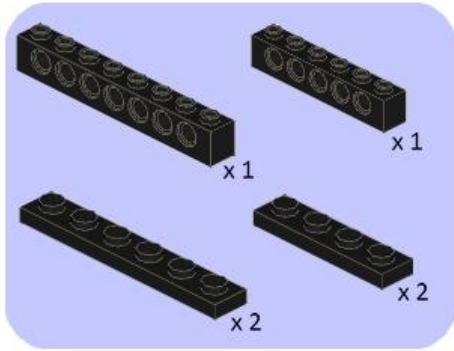

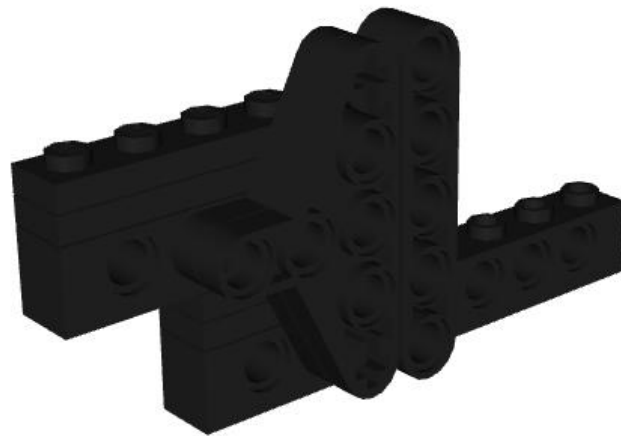
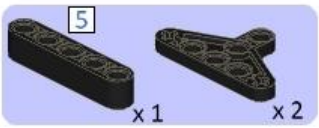

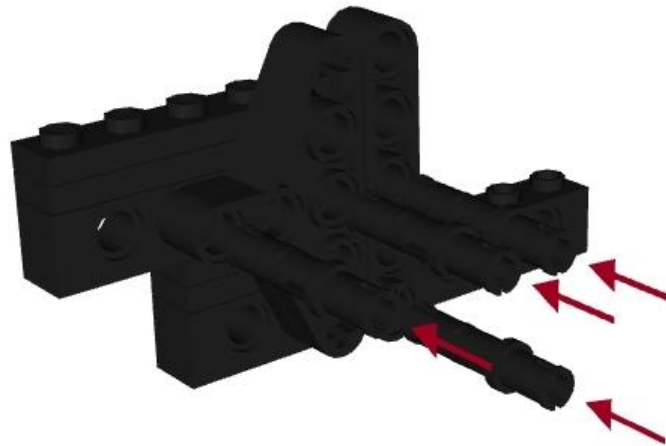

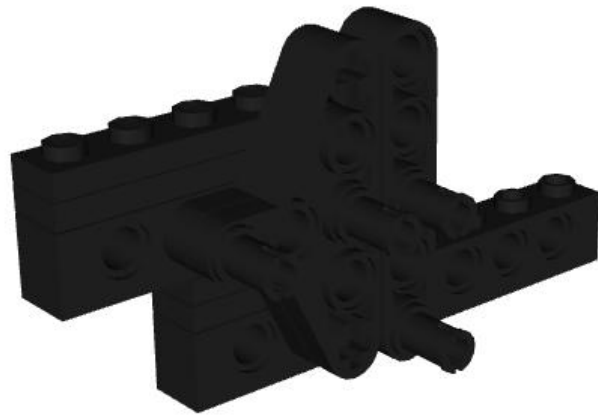

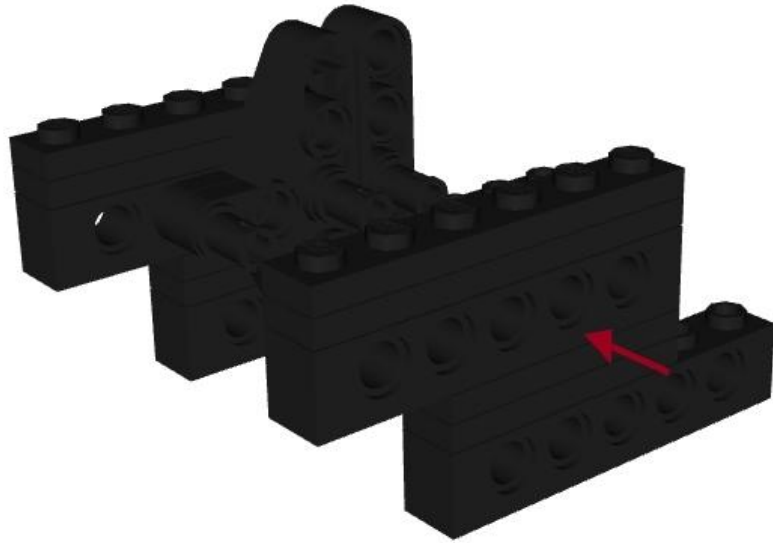
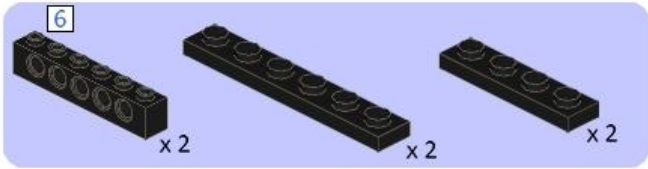

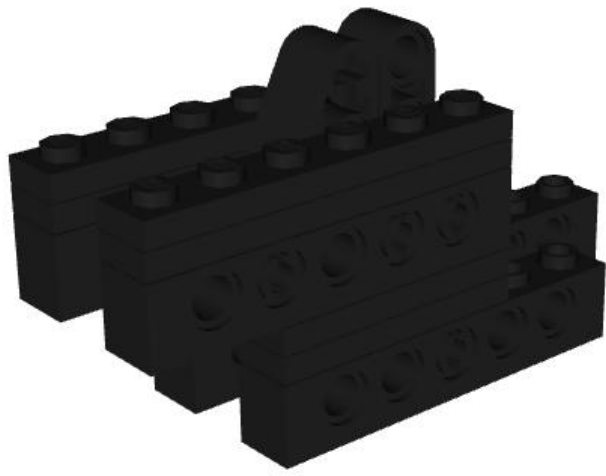

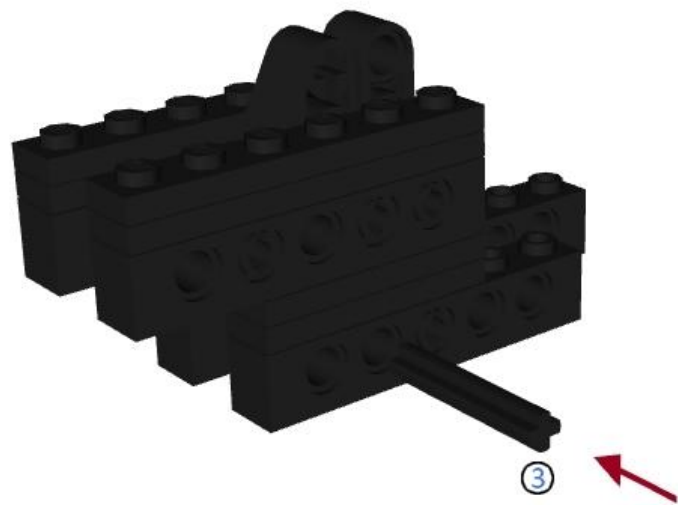

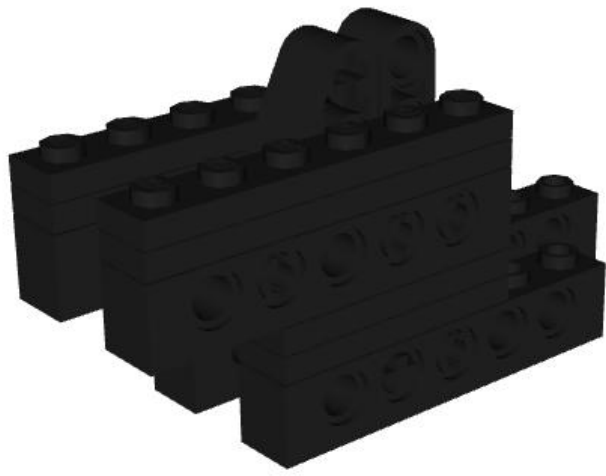

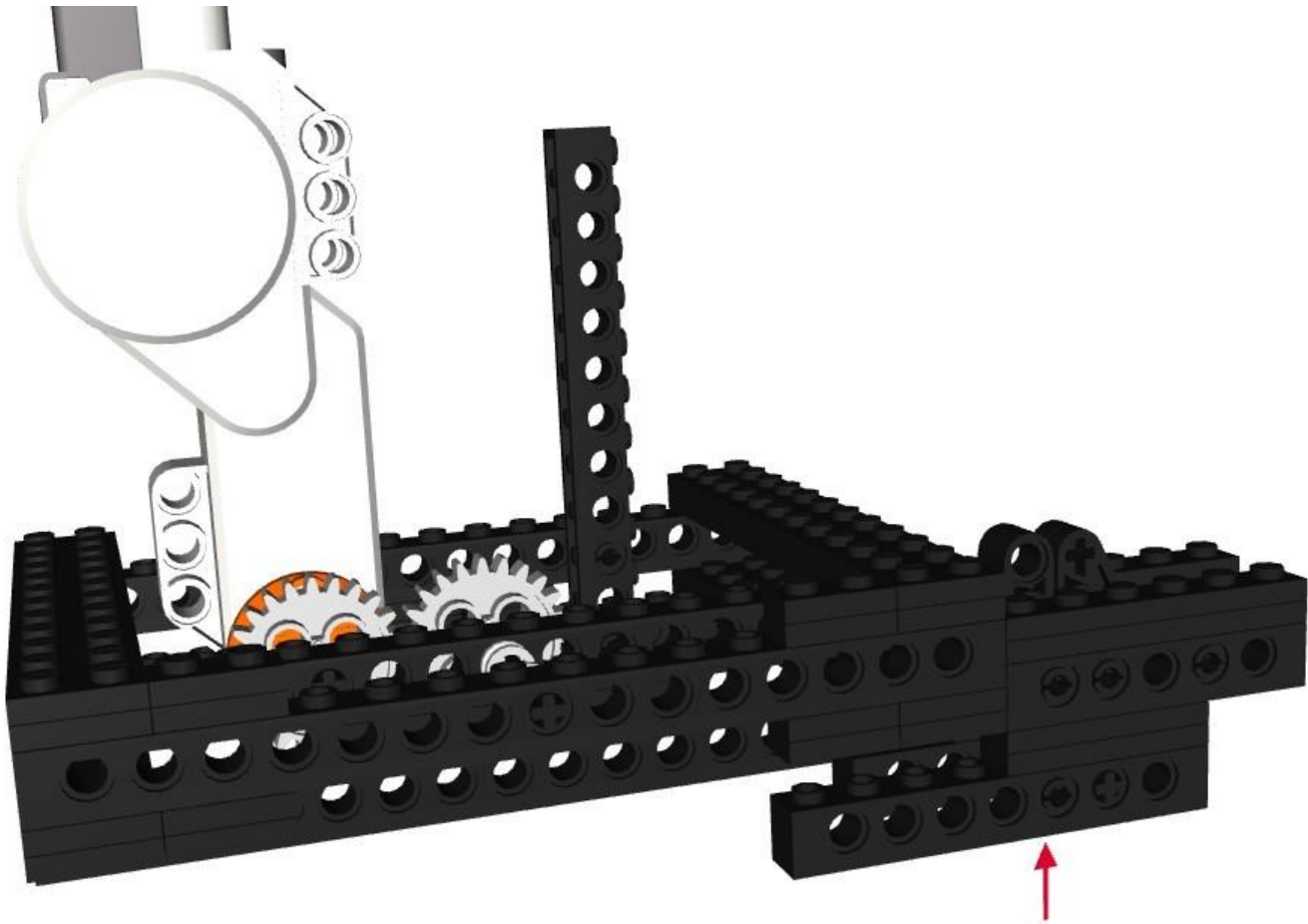

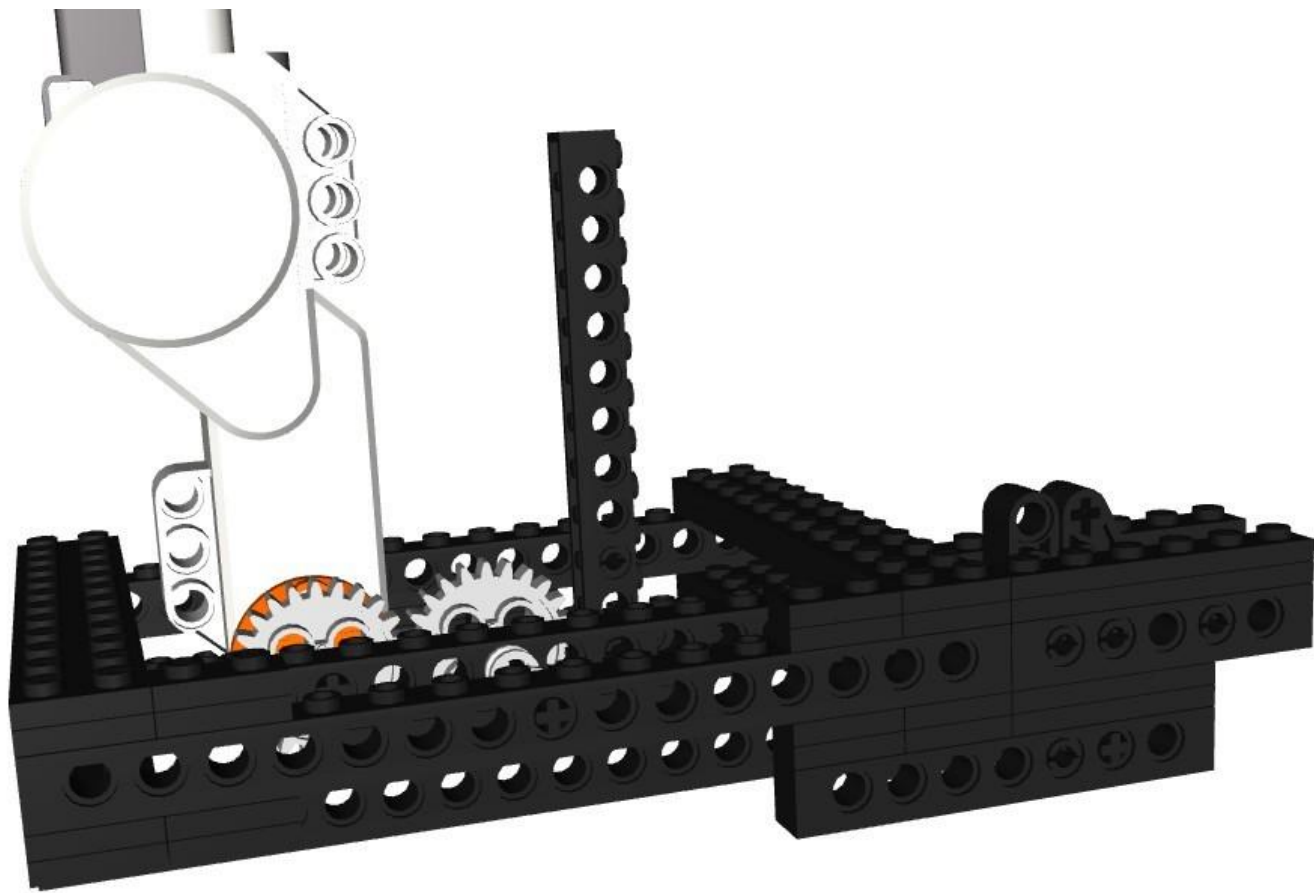

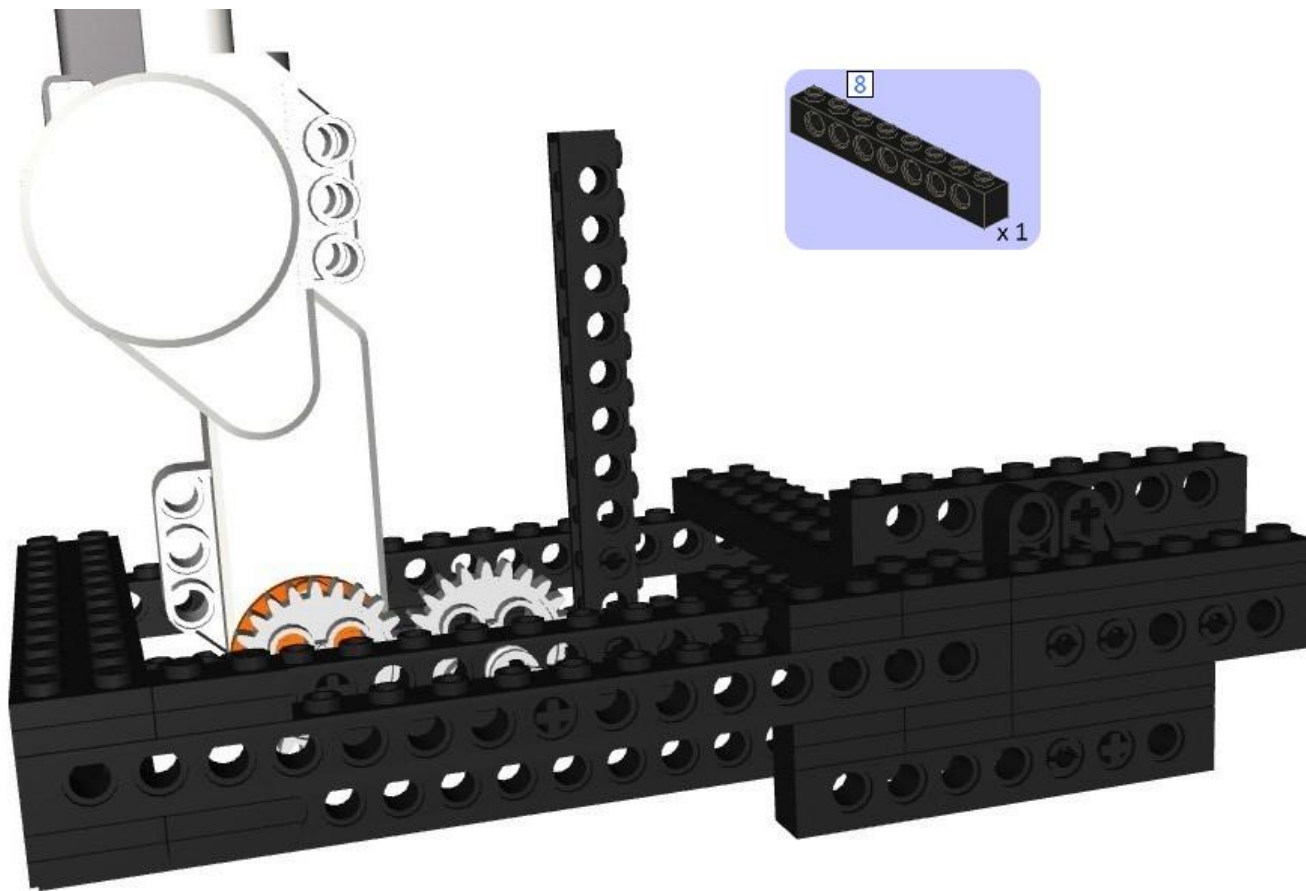

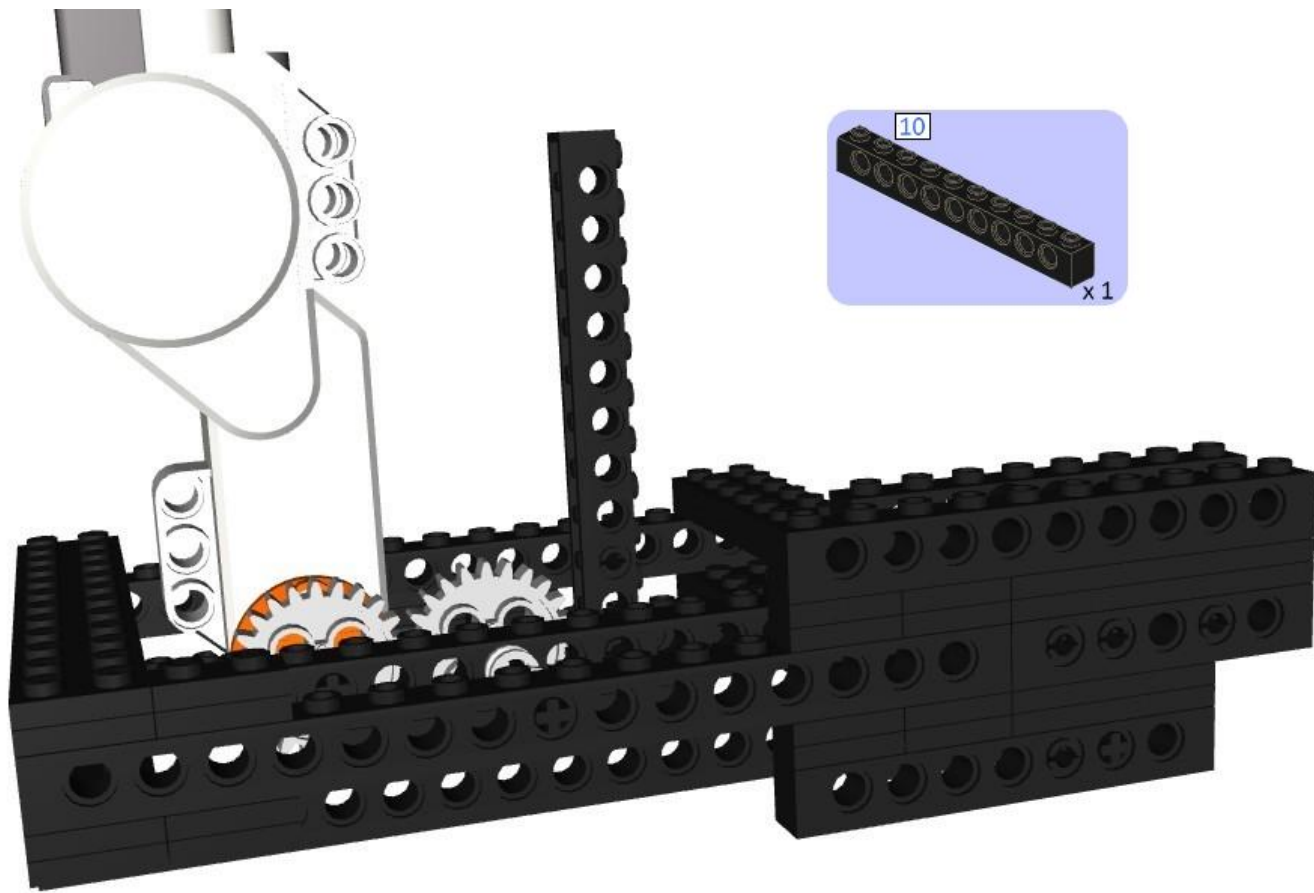

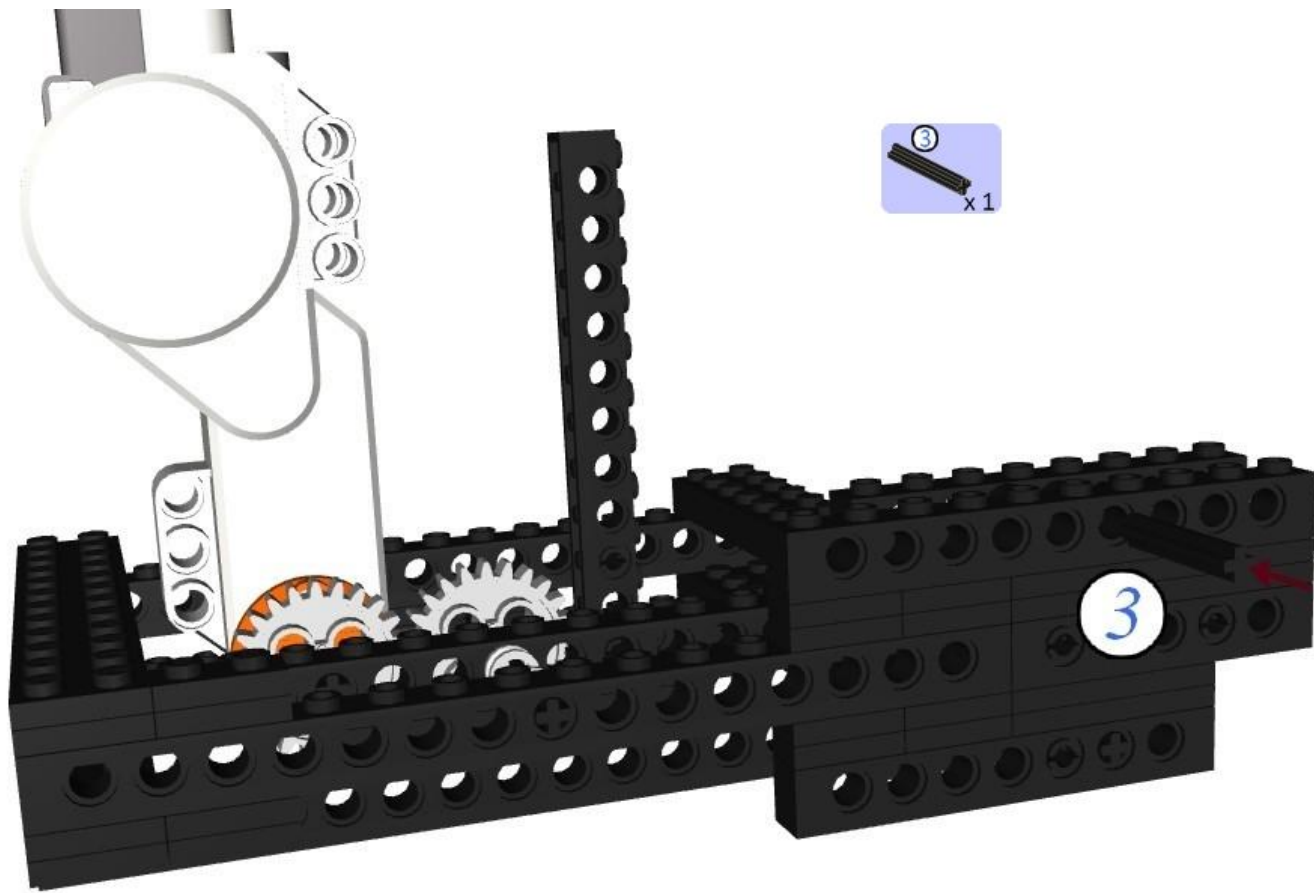

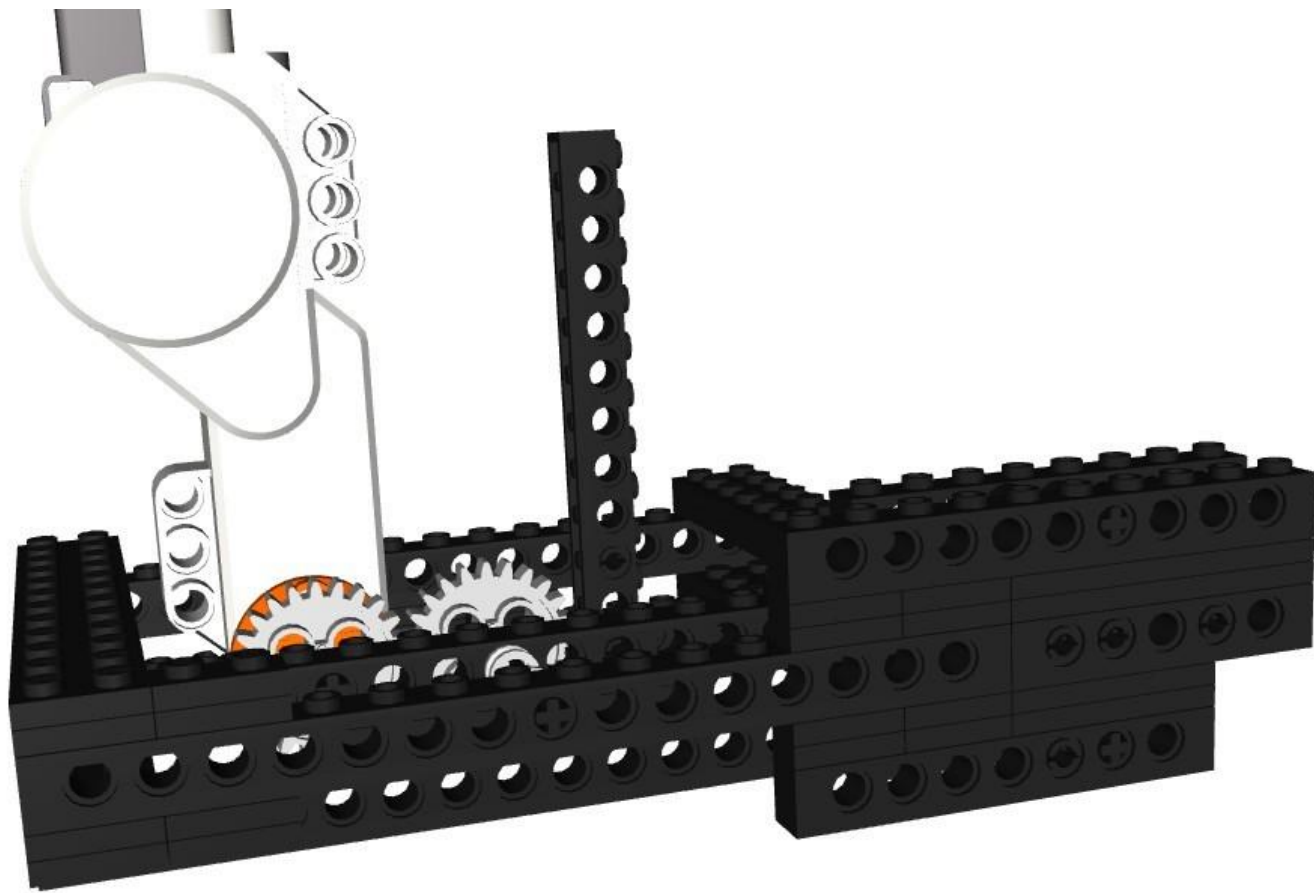

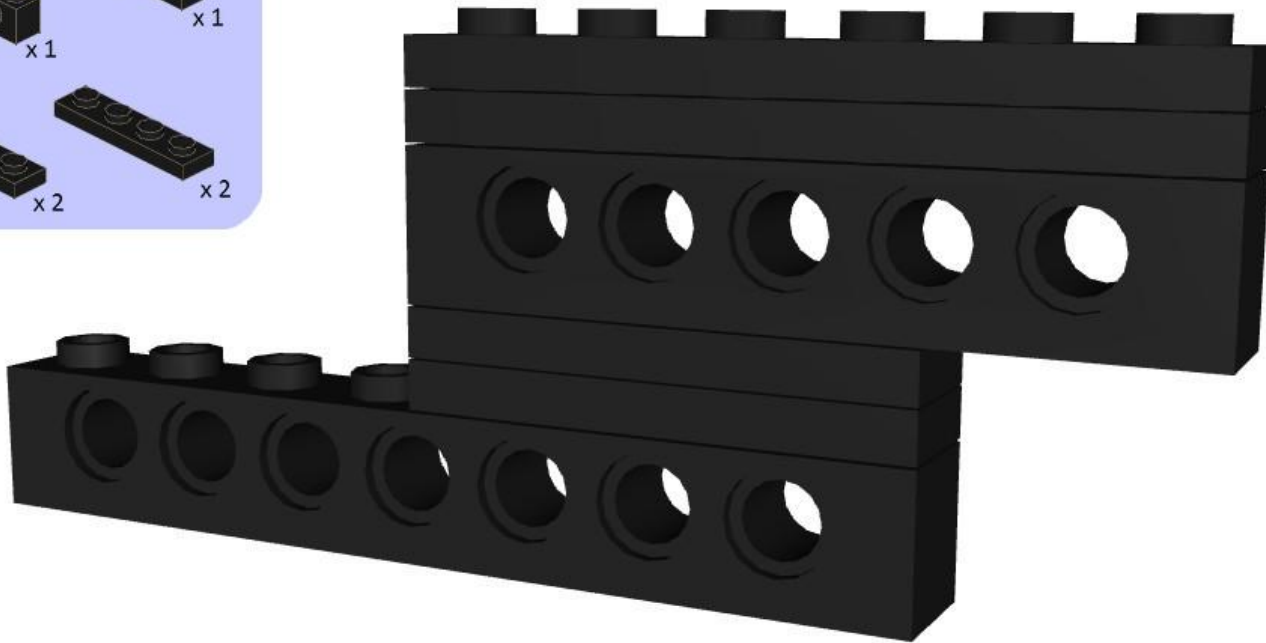
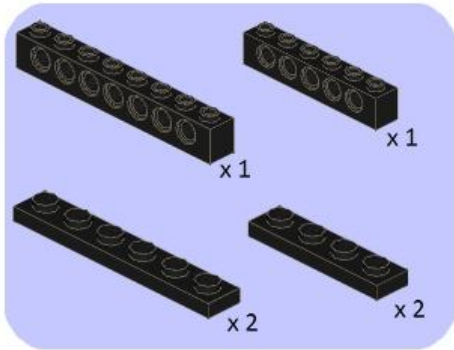

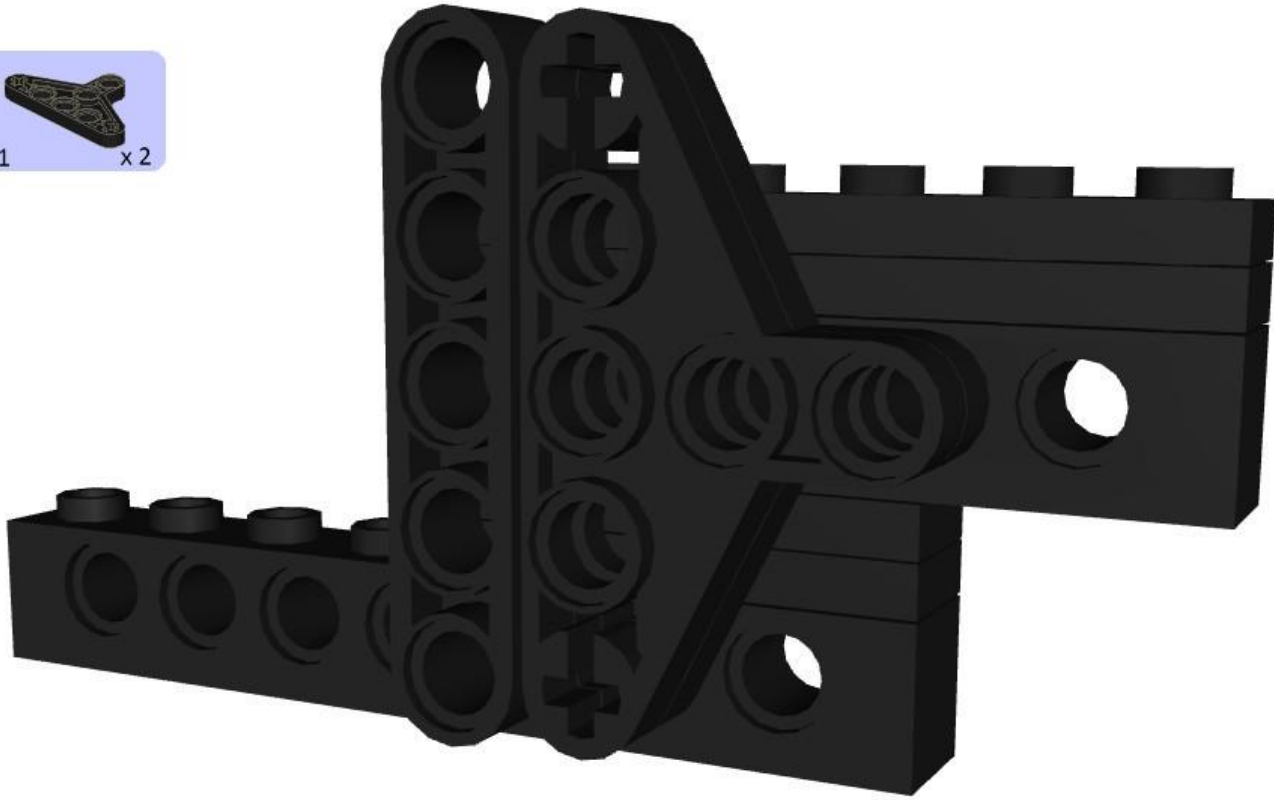
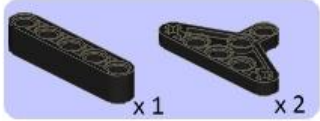

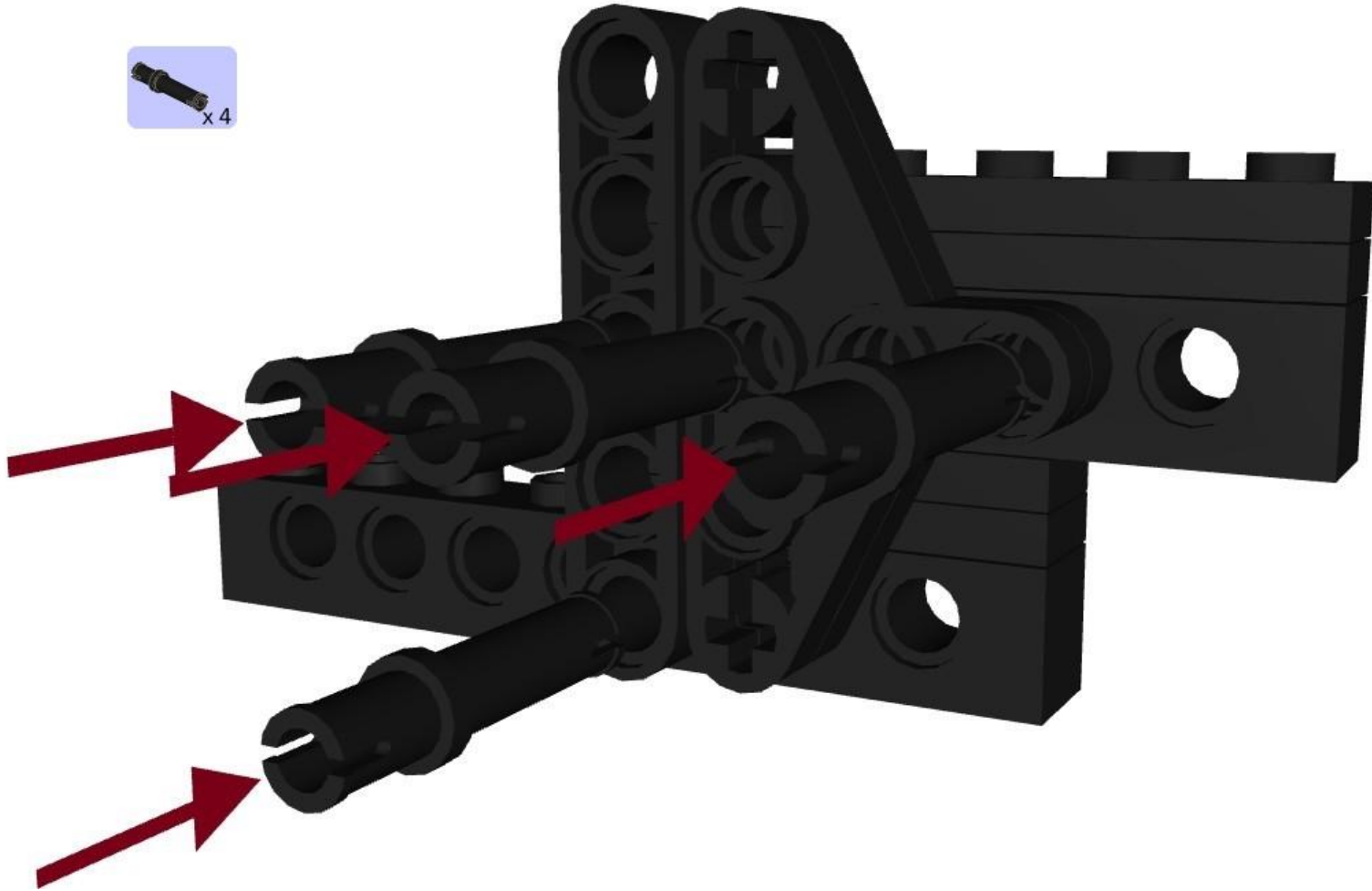

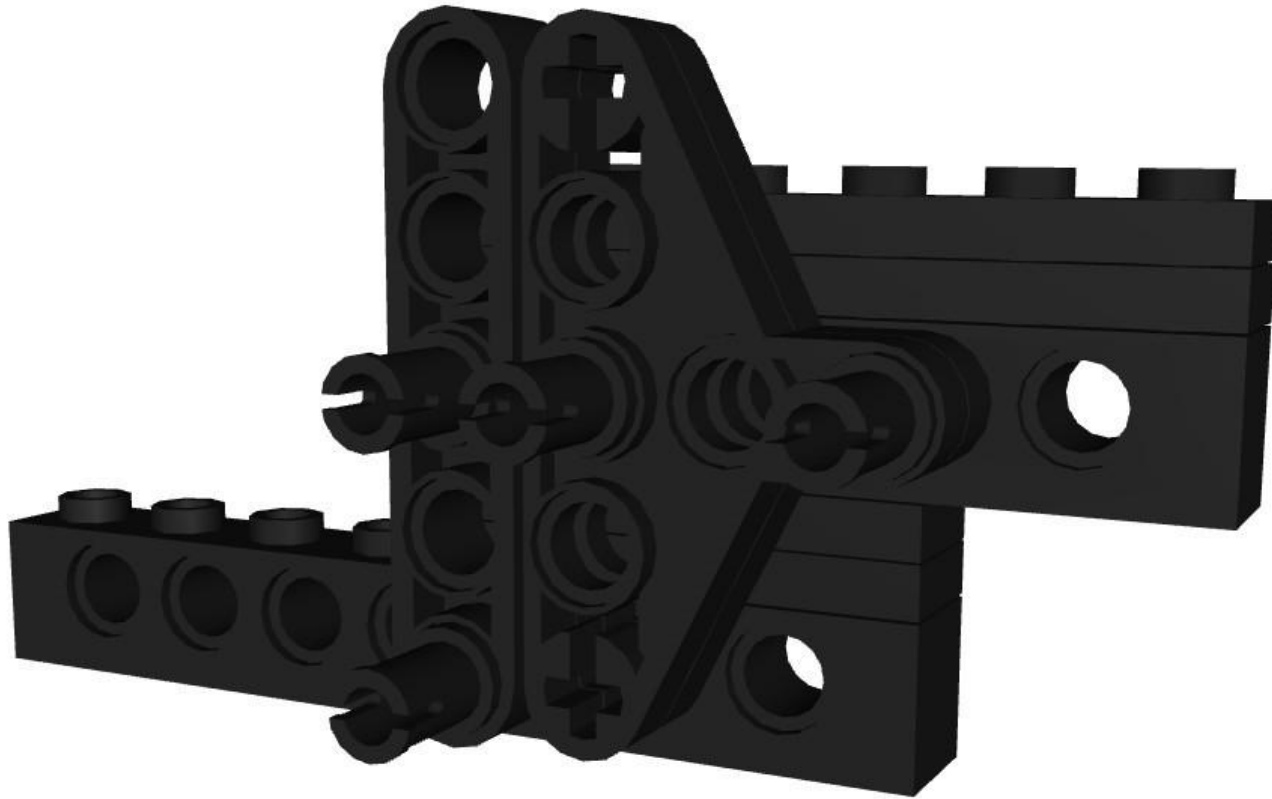

41/147

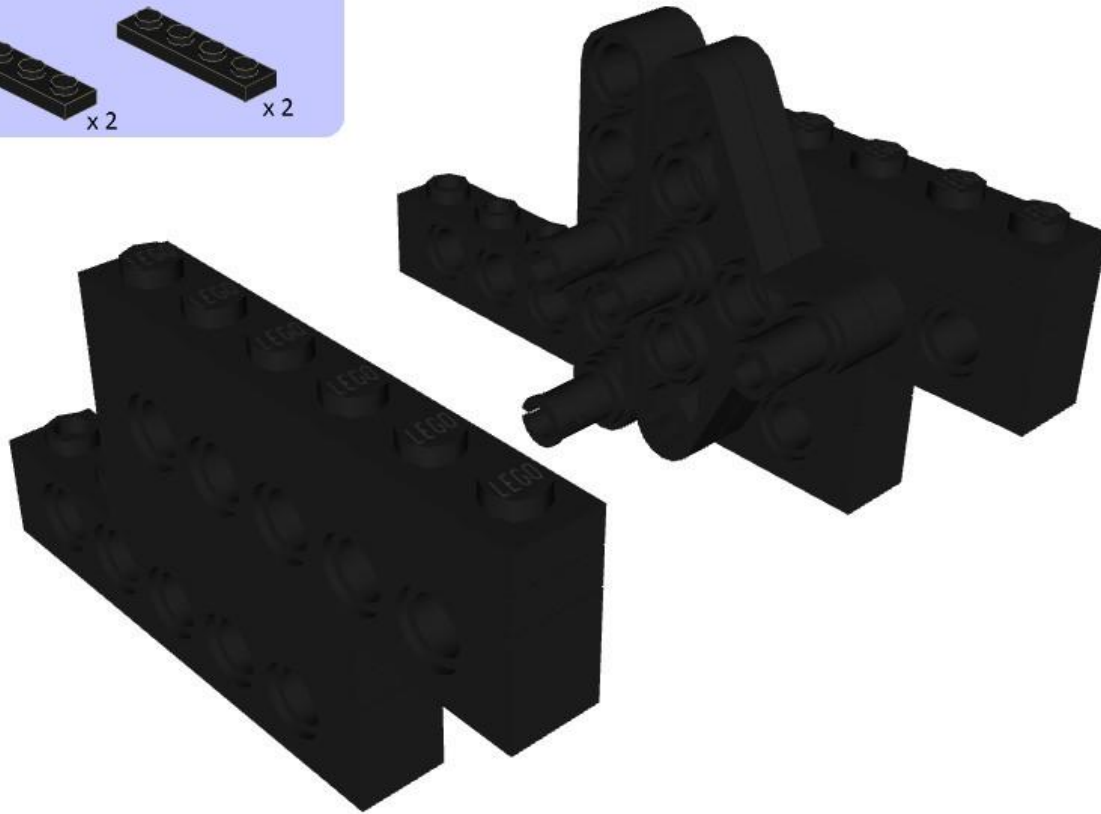
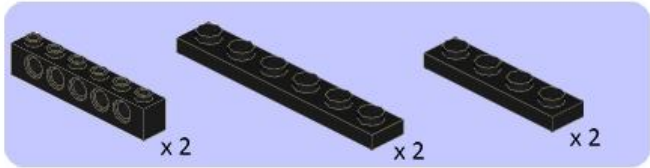

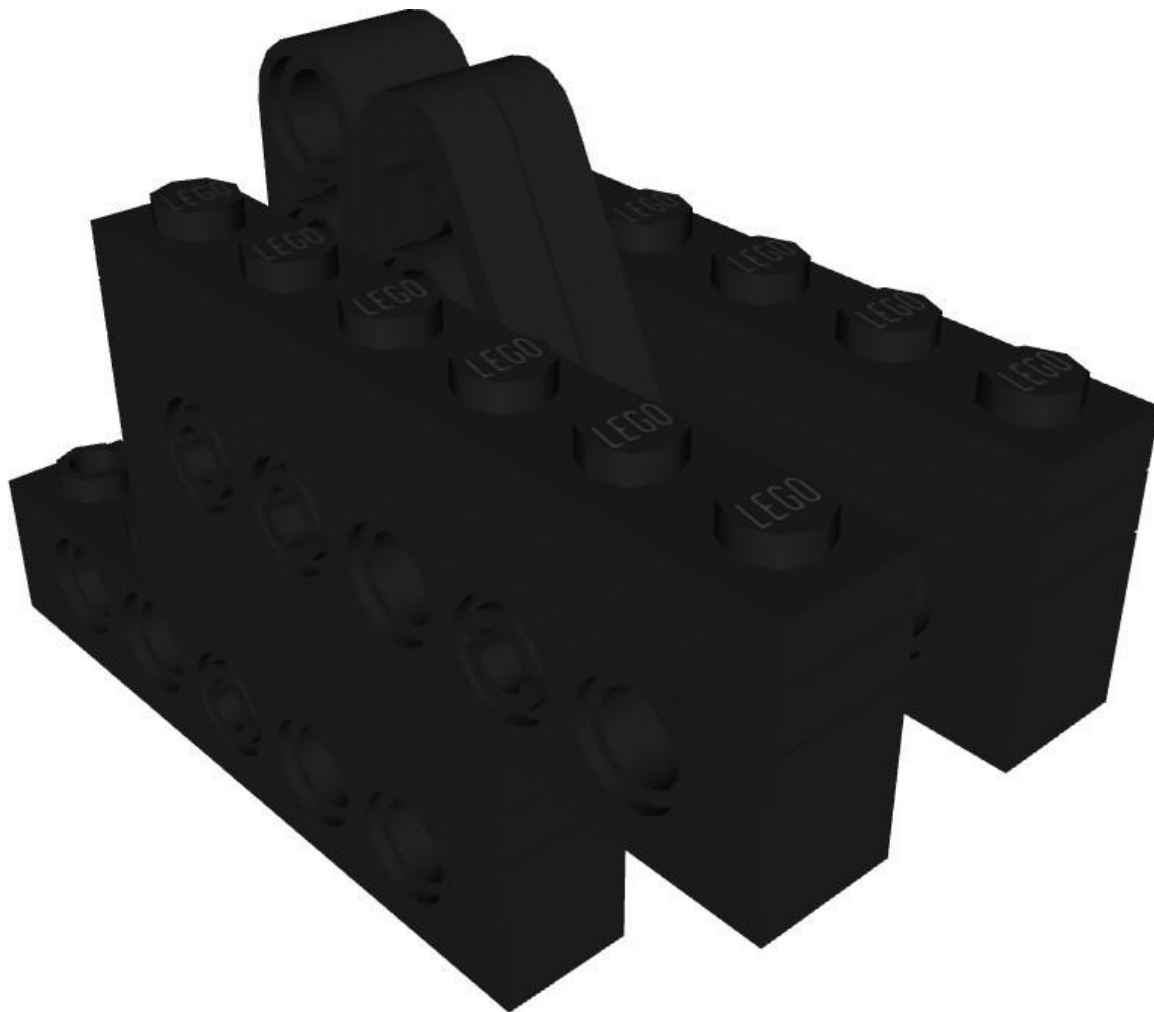

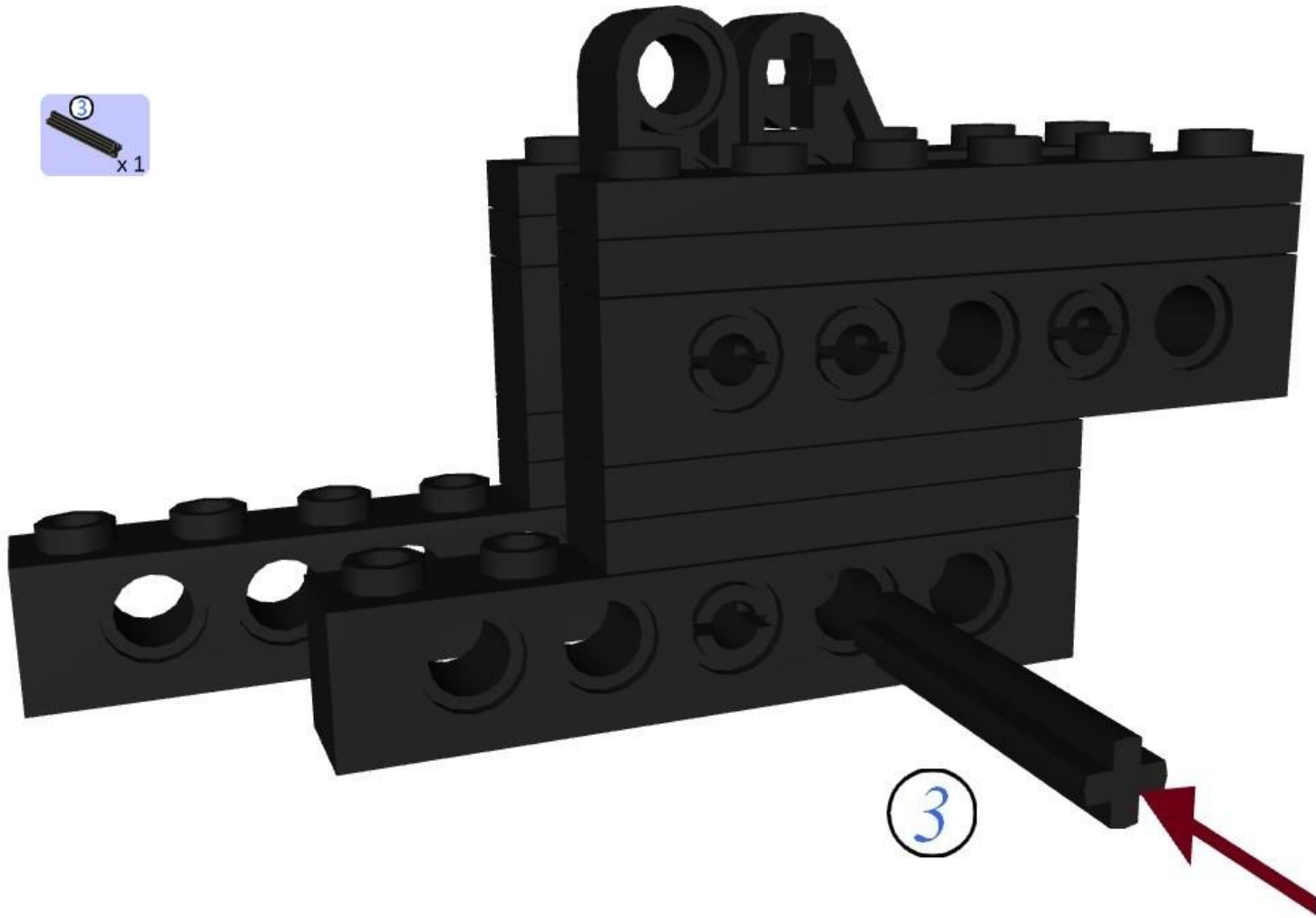

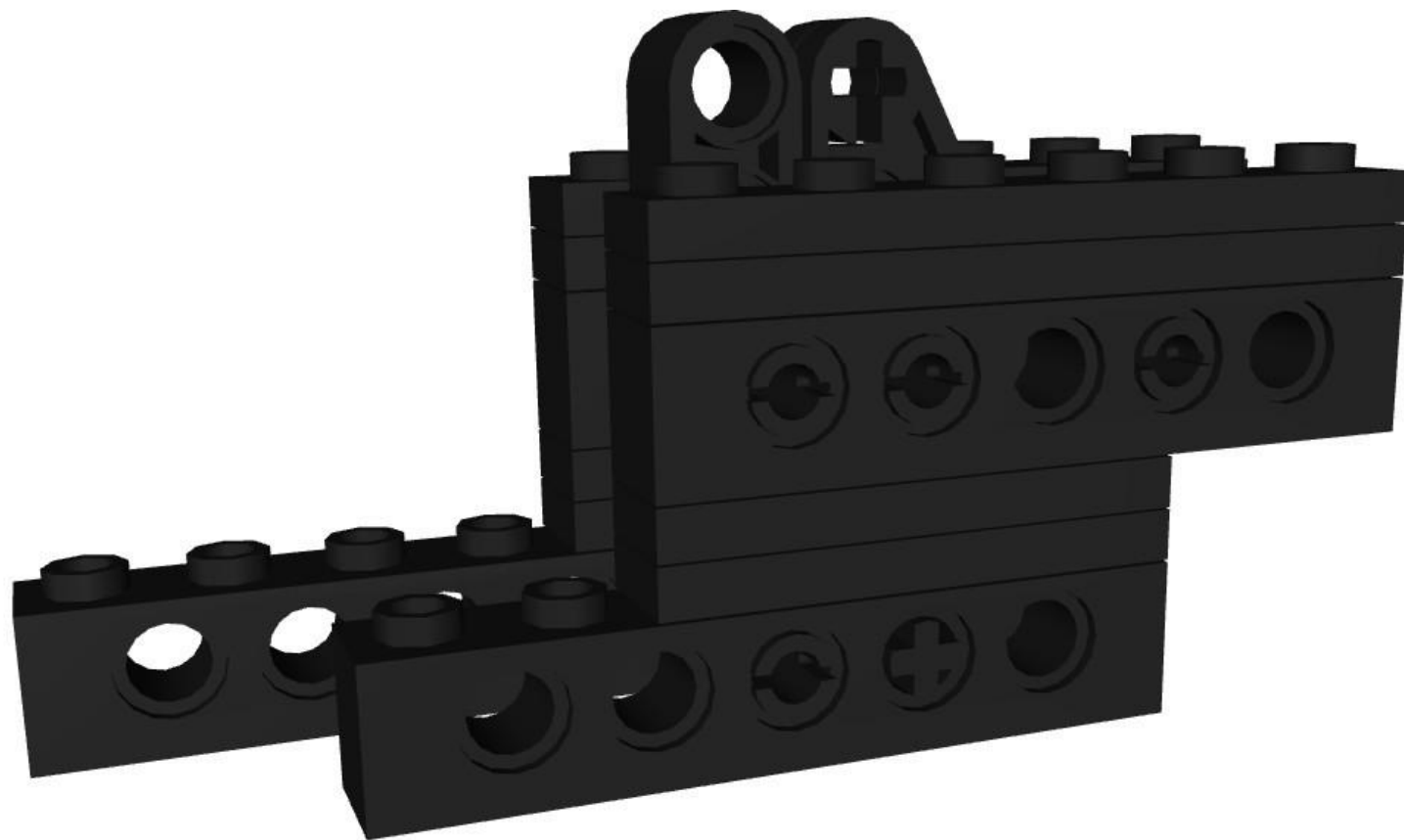

45/147

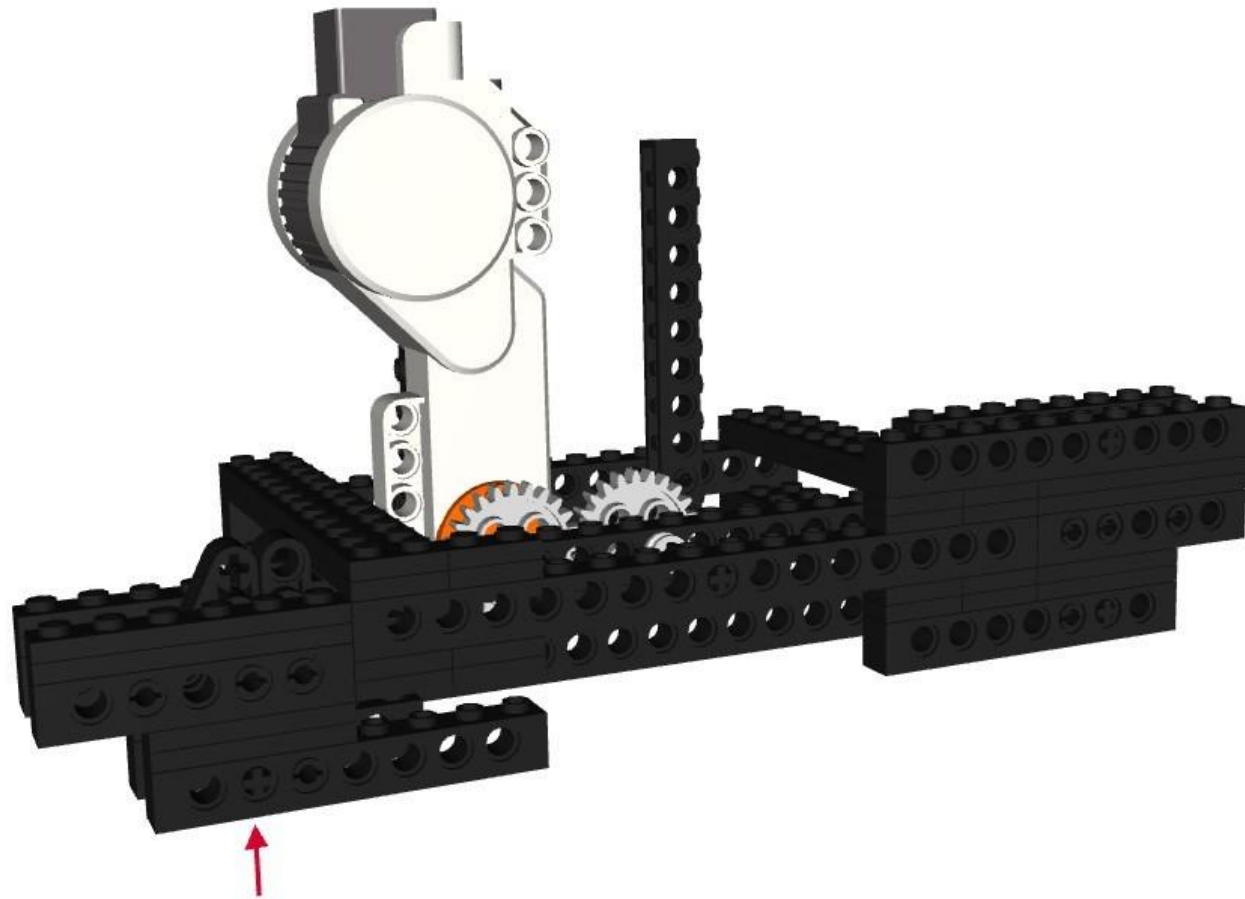

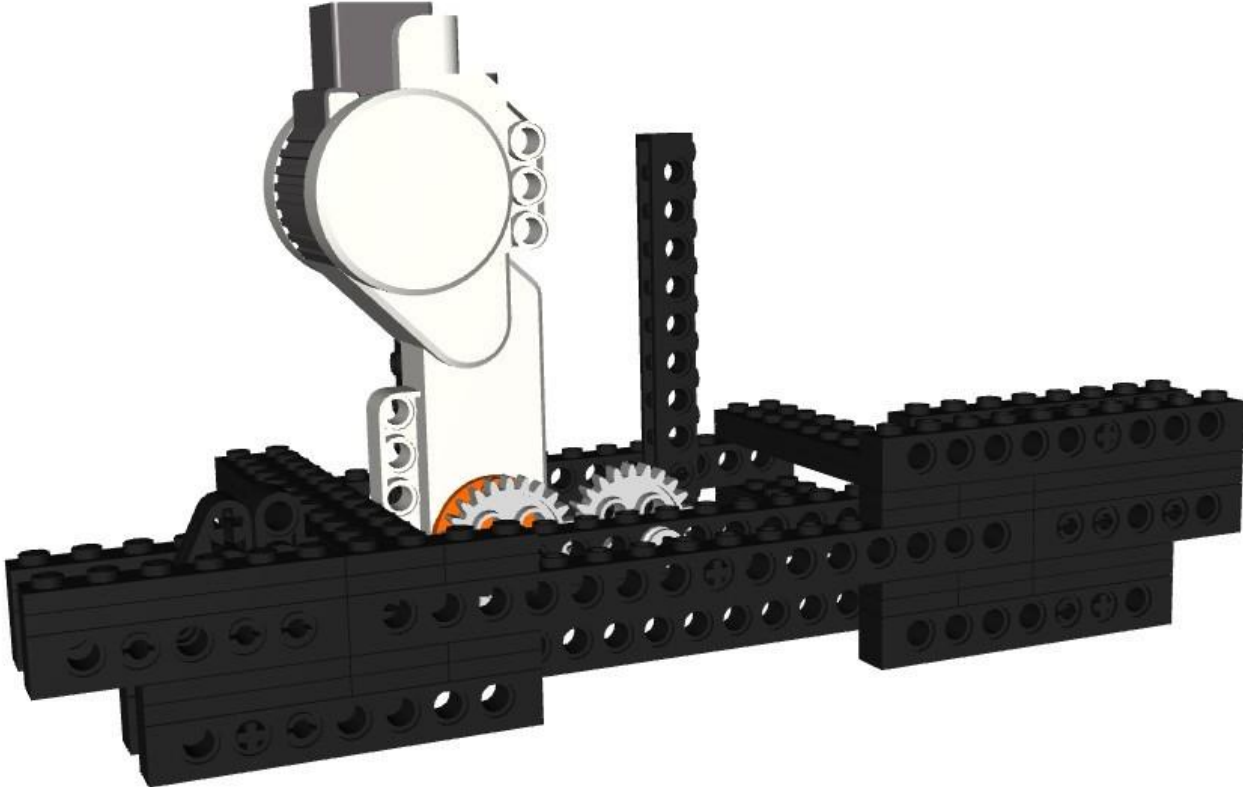

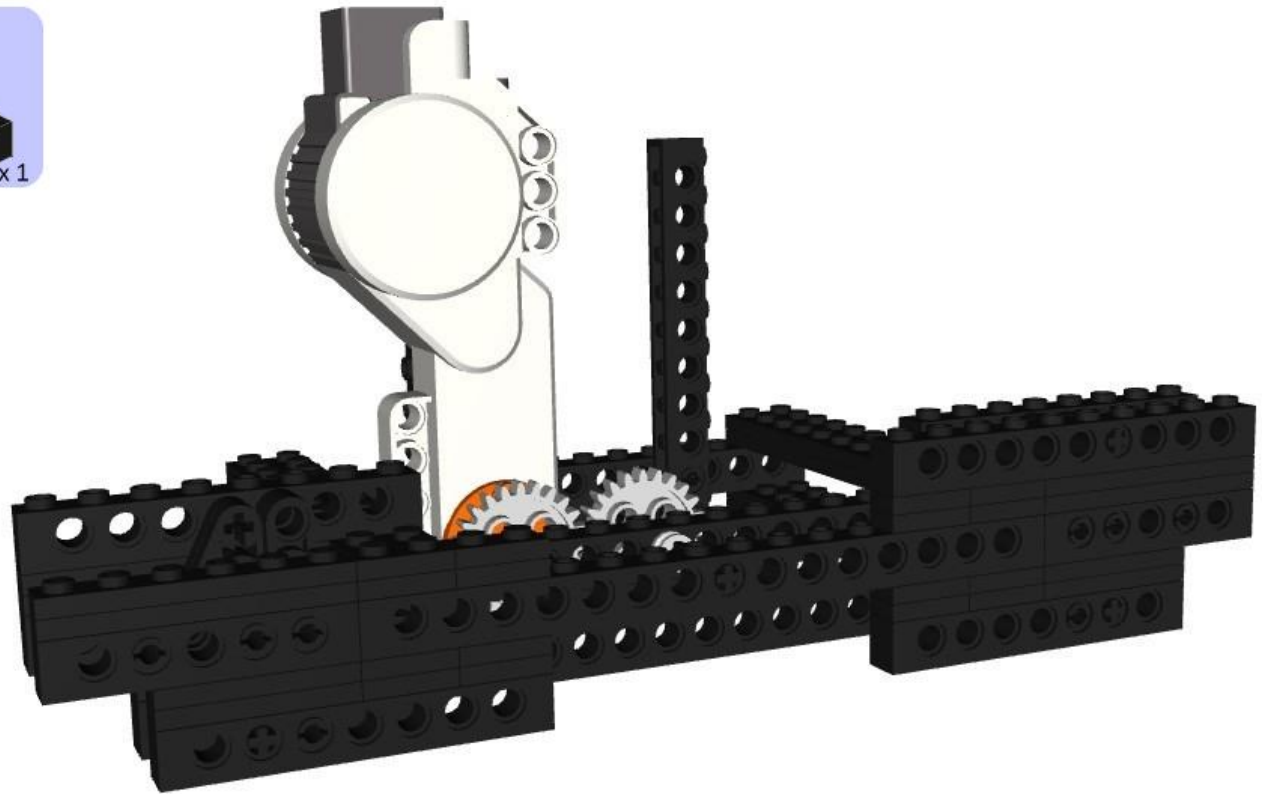
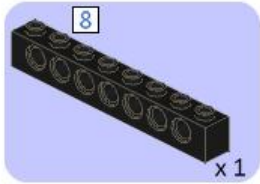

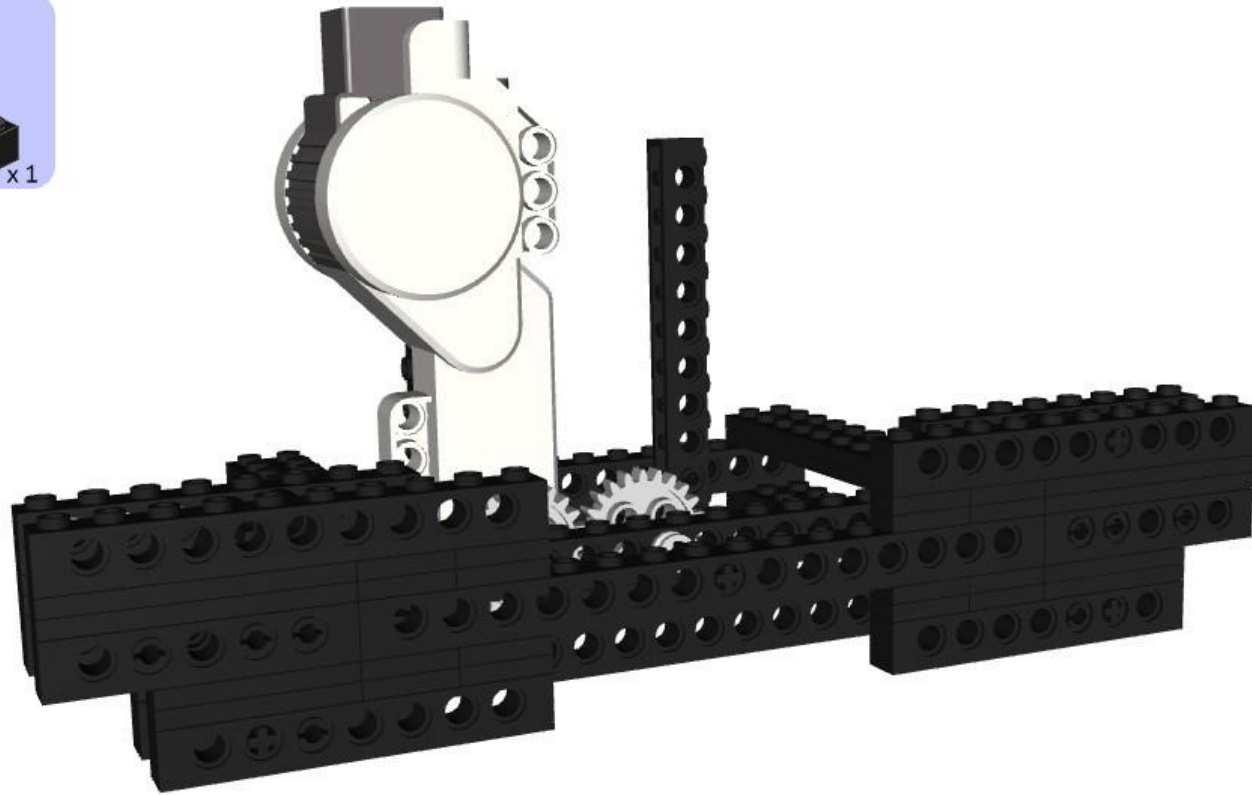
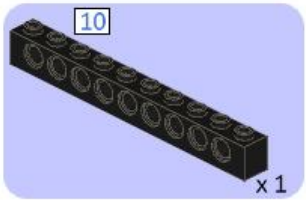

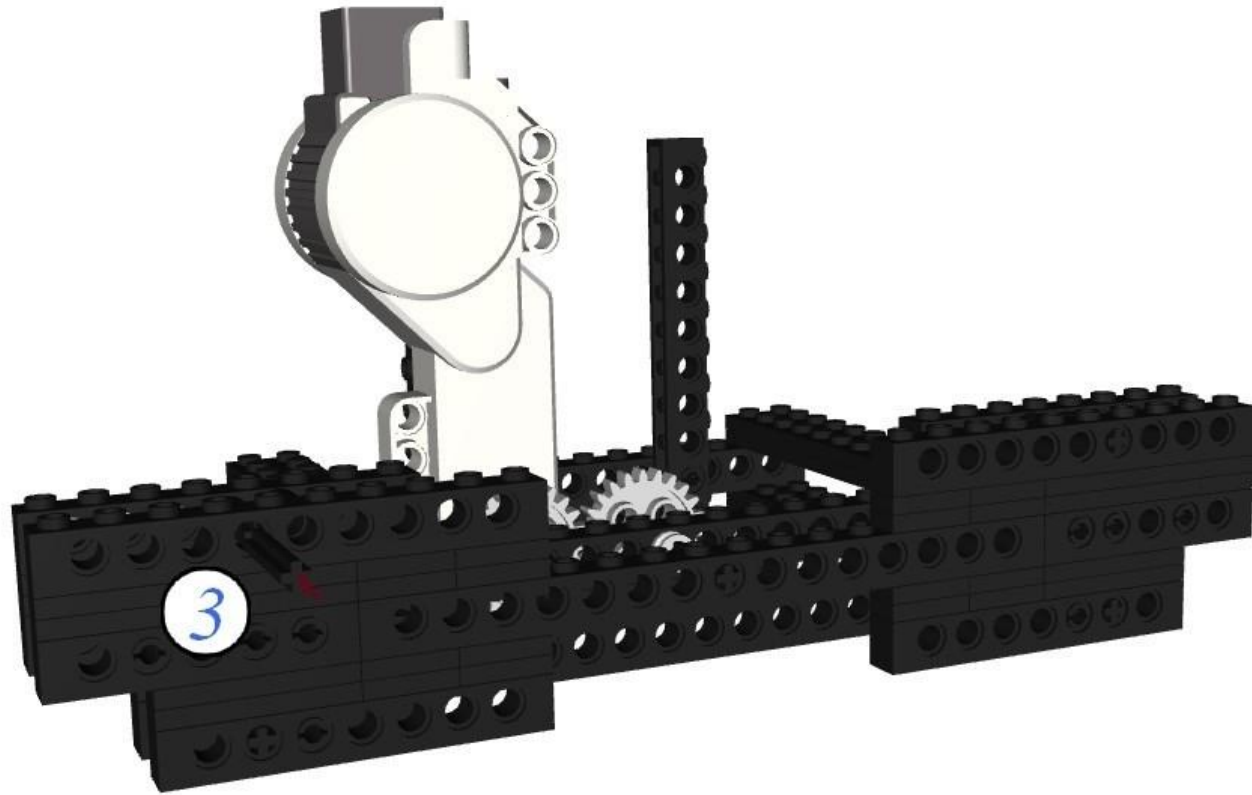
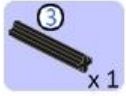

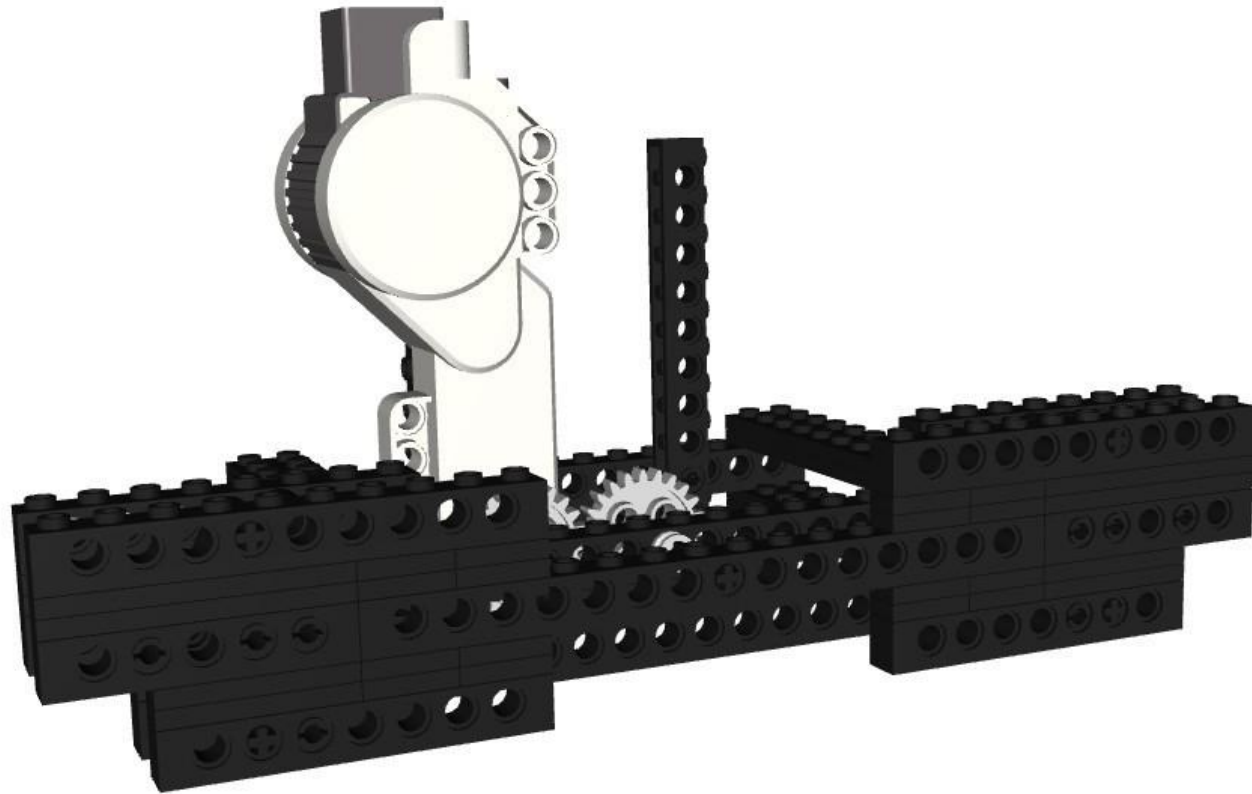

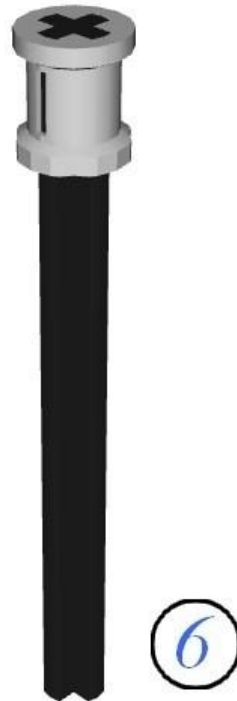
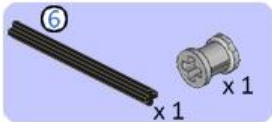



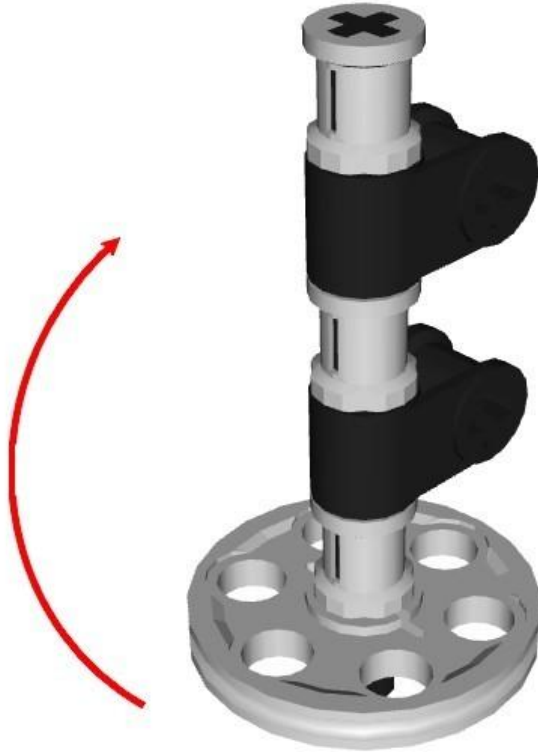
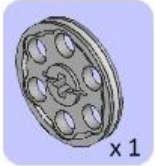





x 2

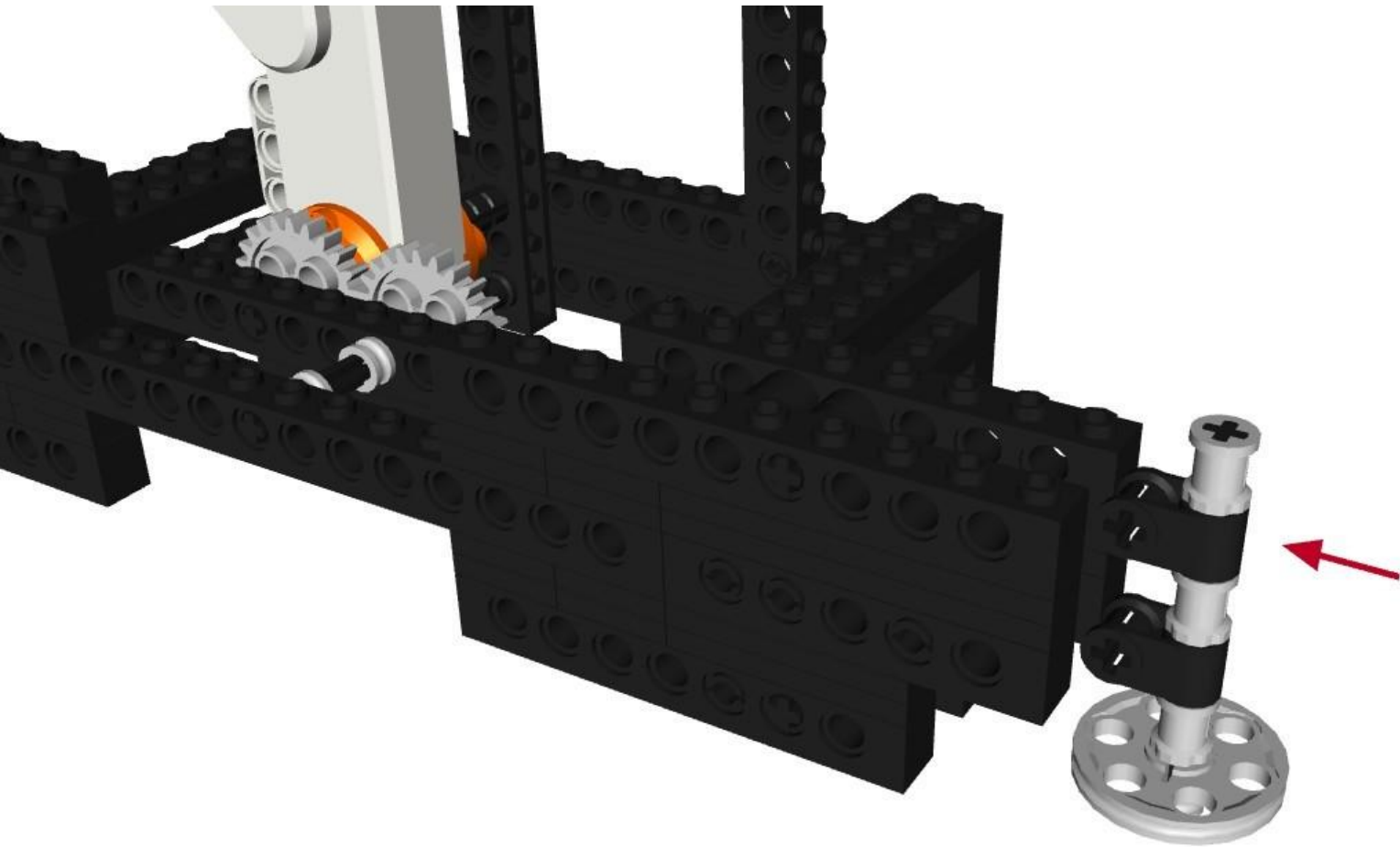

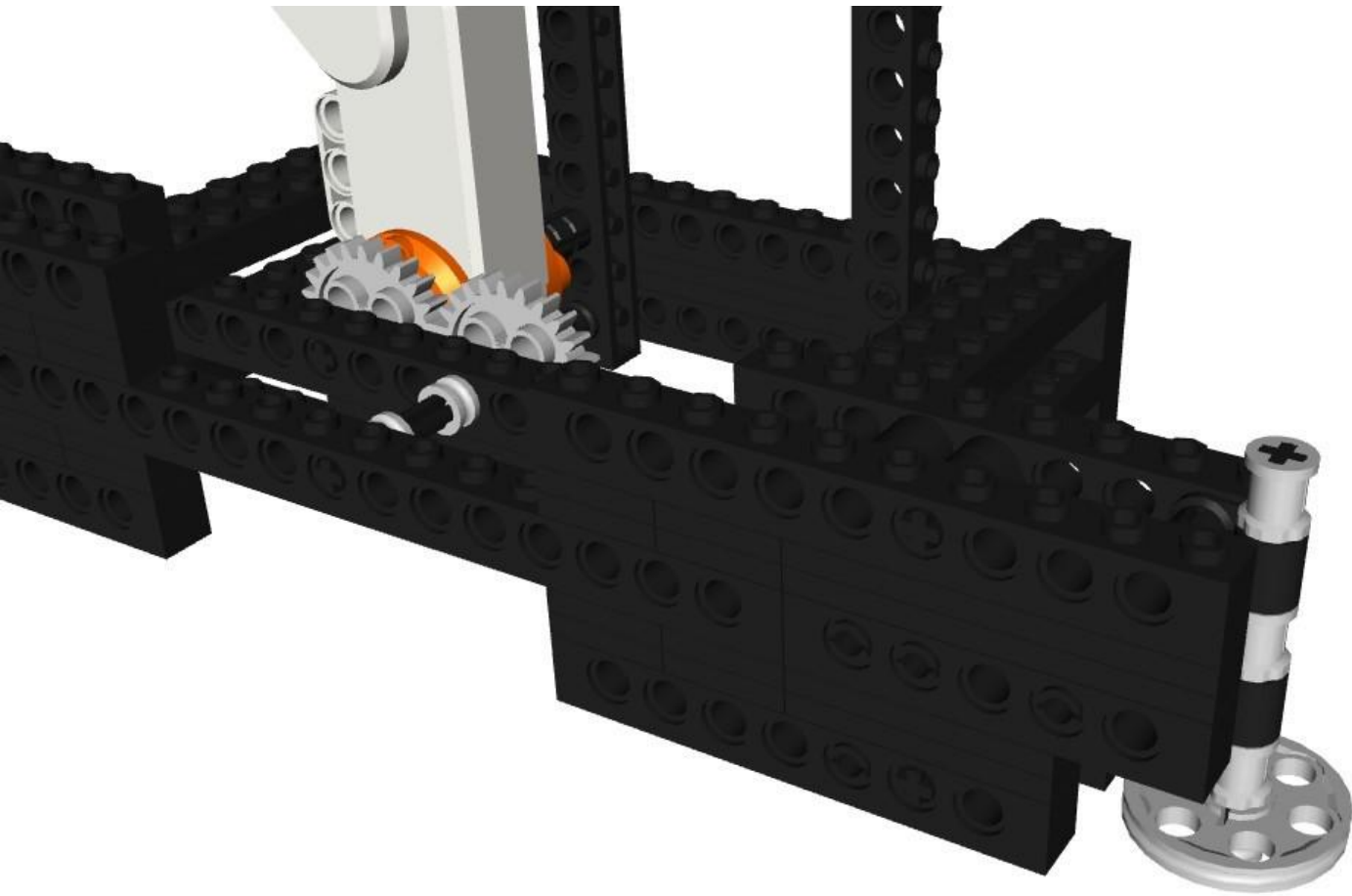

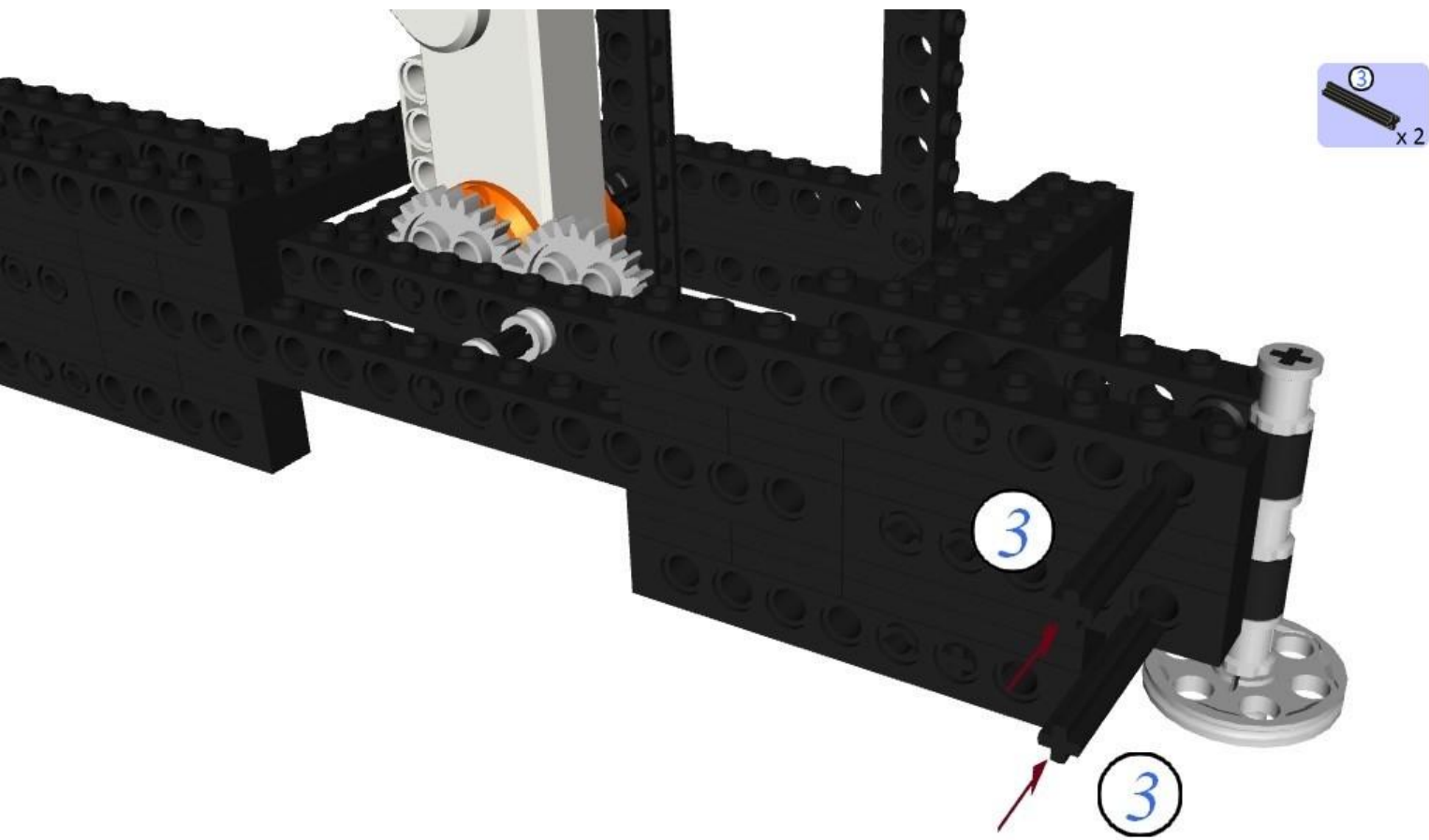

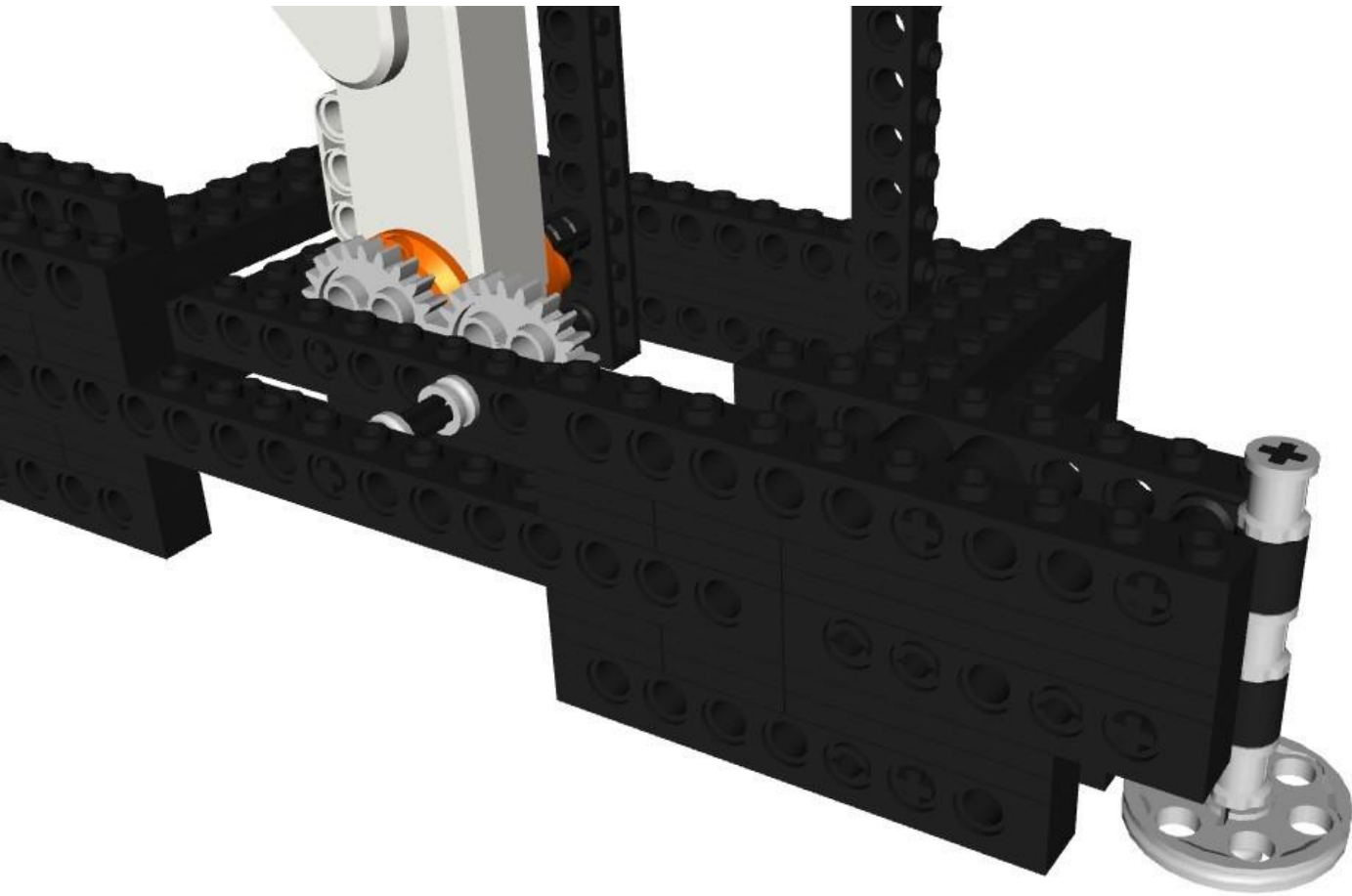

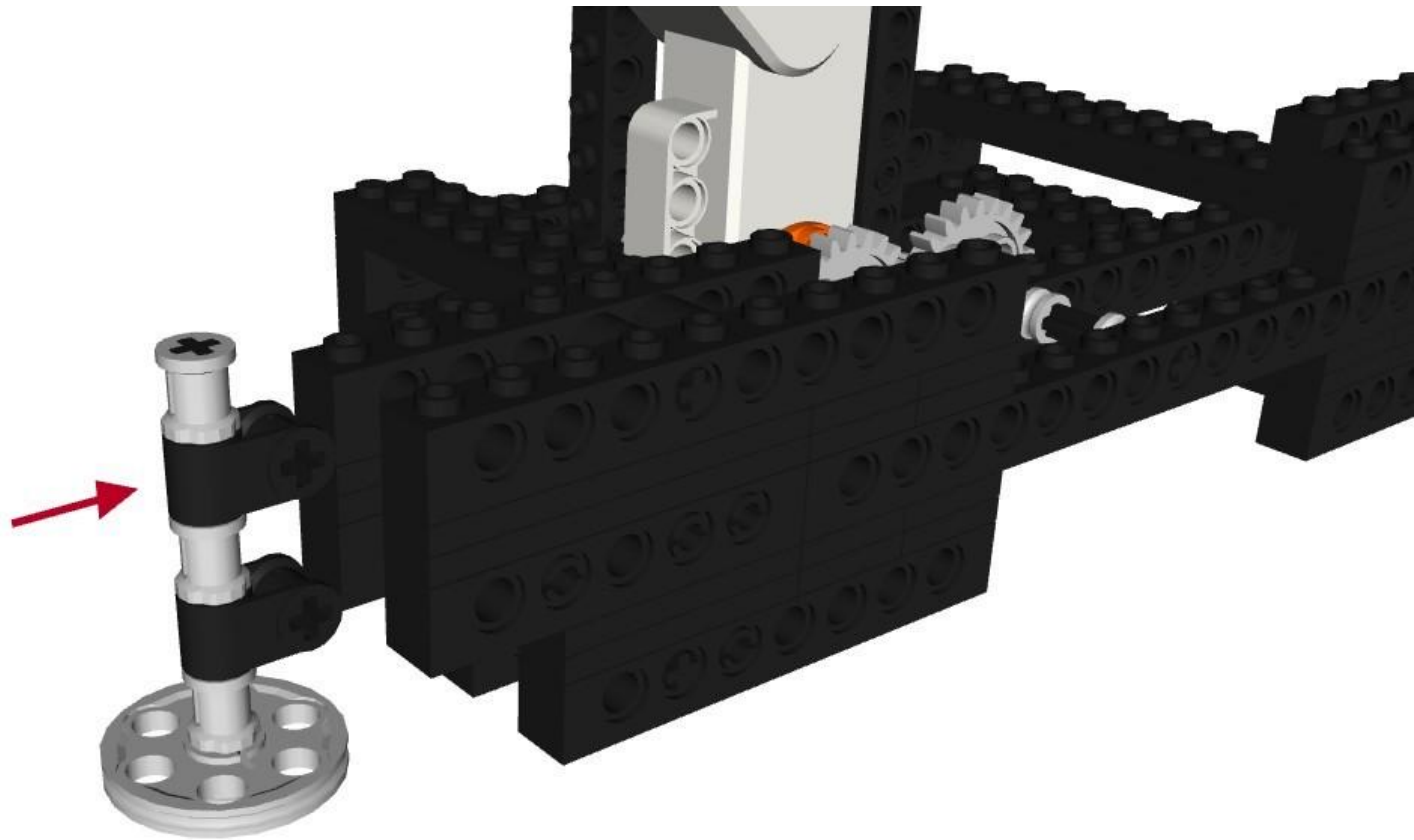

61/147

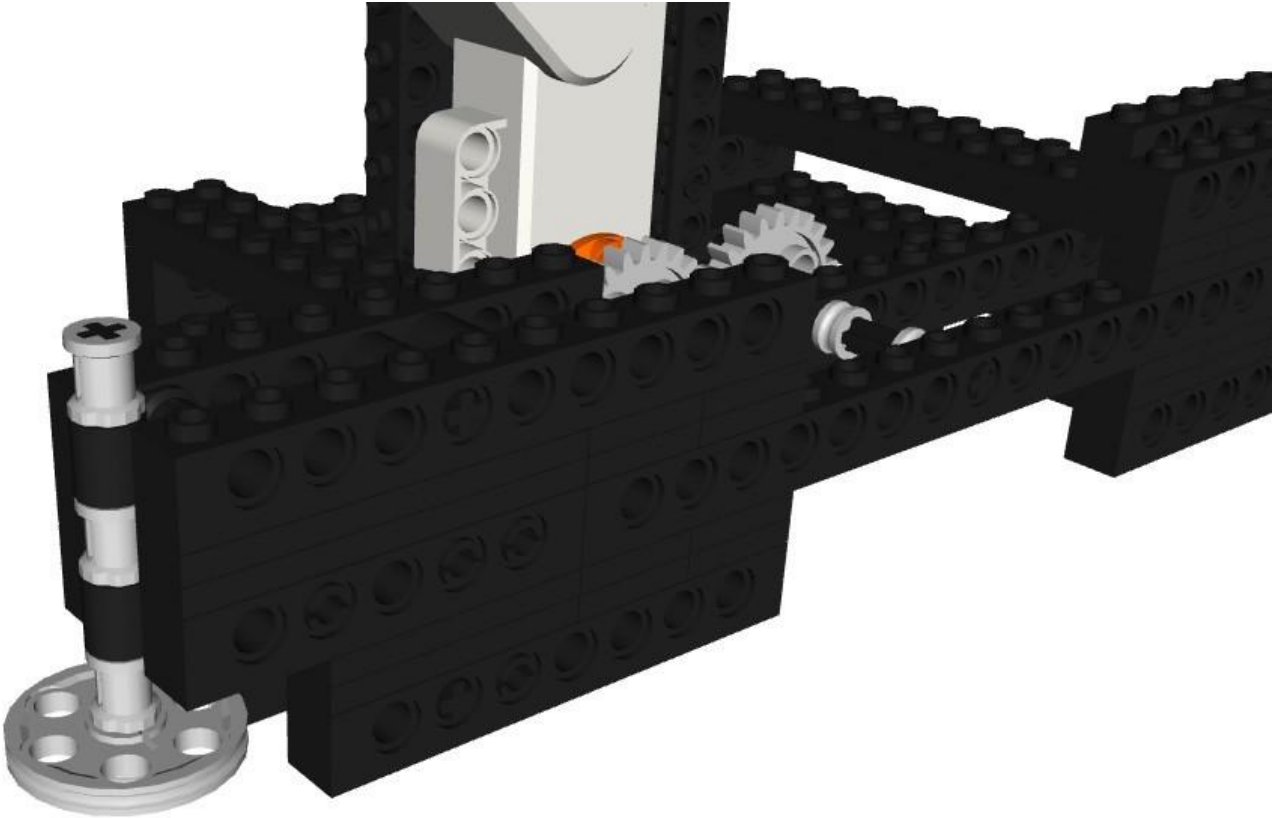

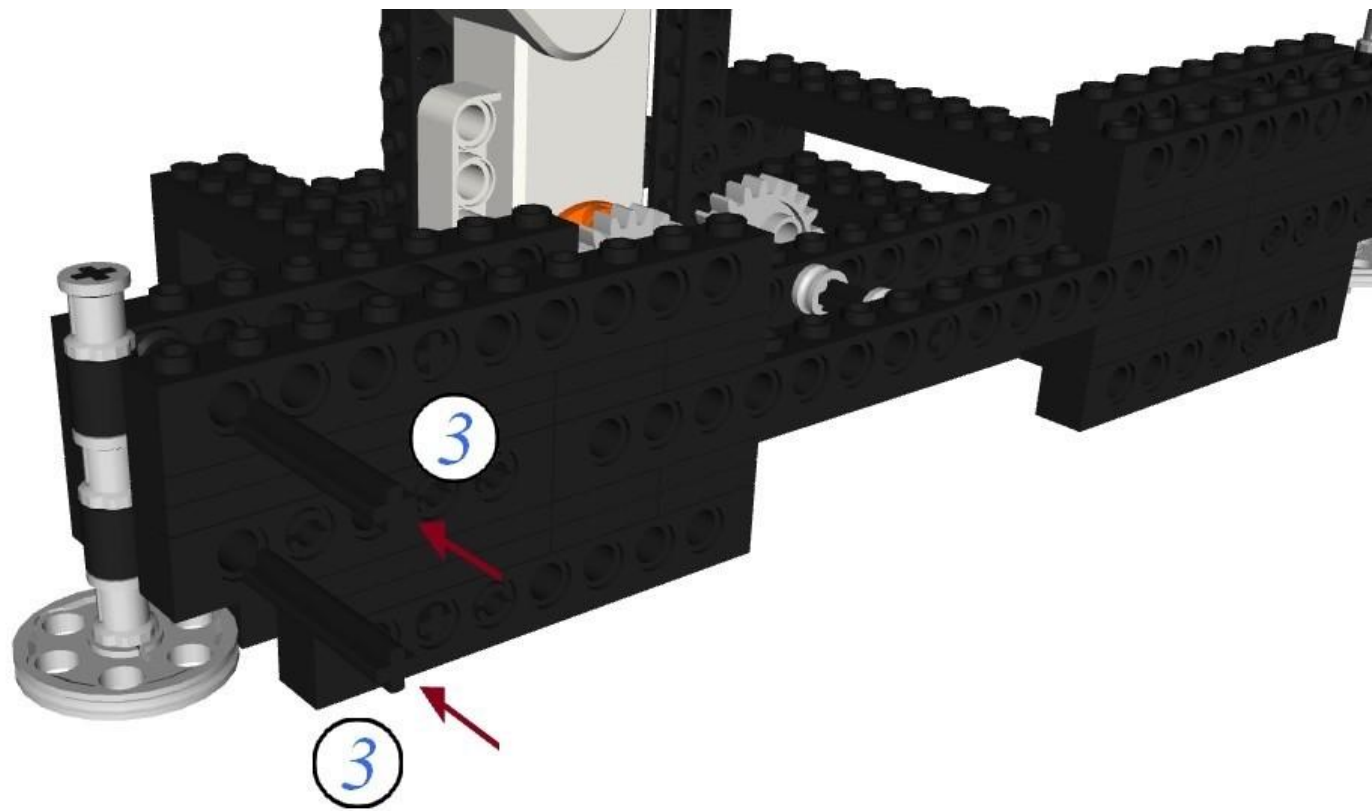
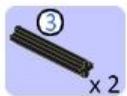

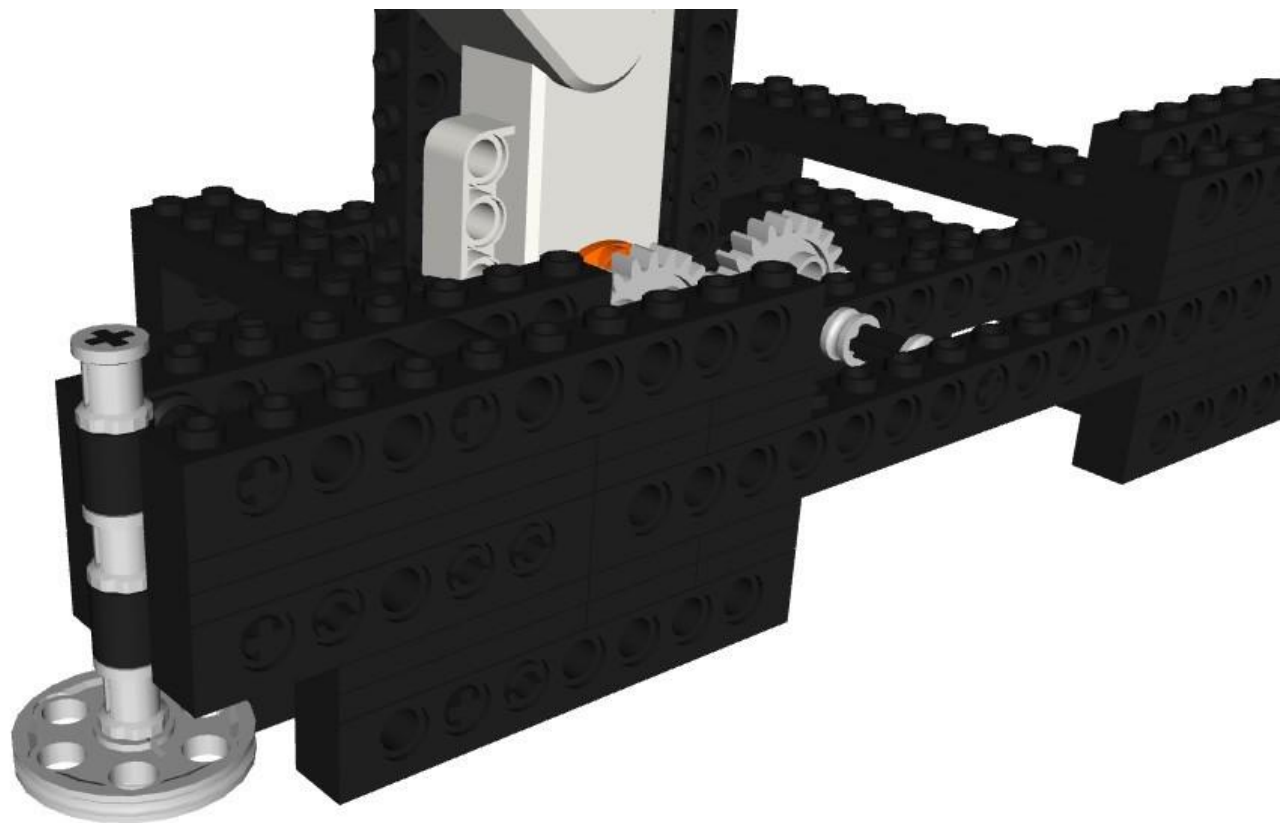

64/147

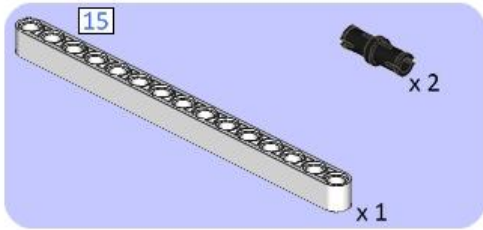

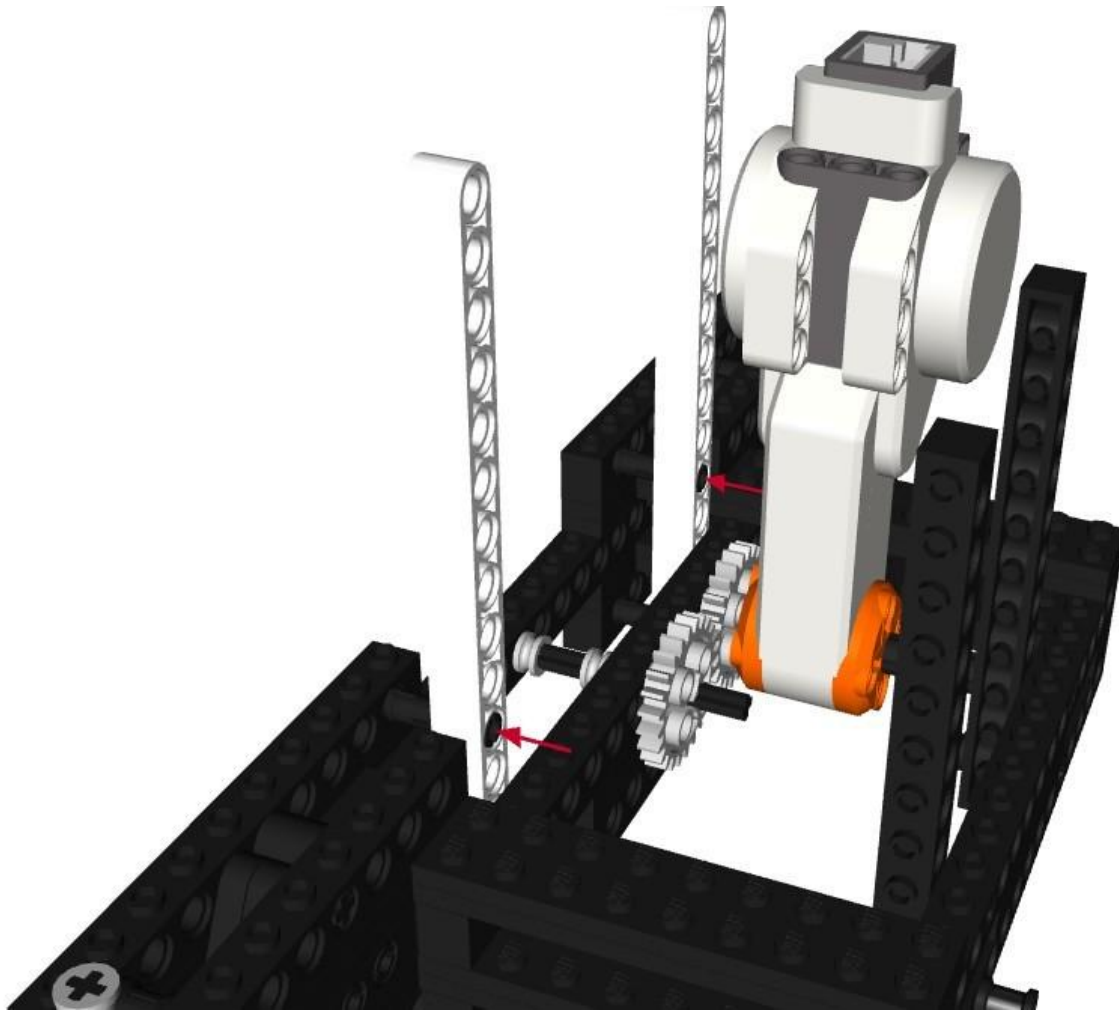

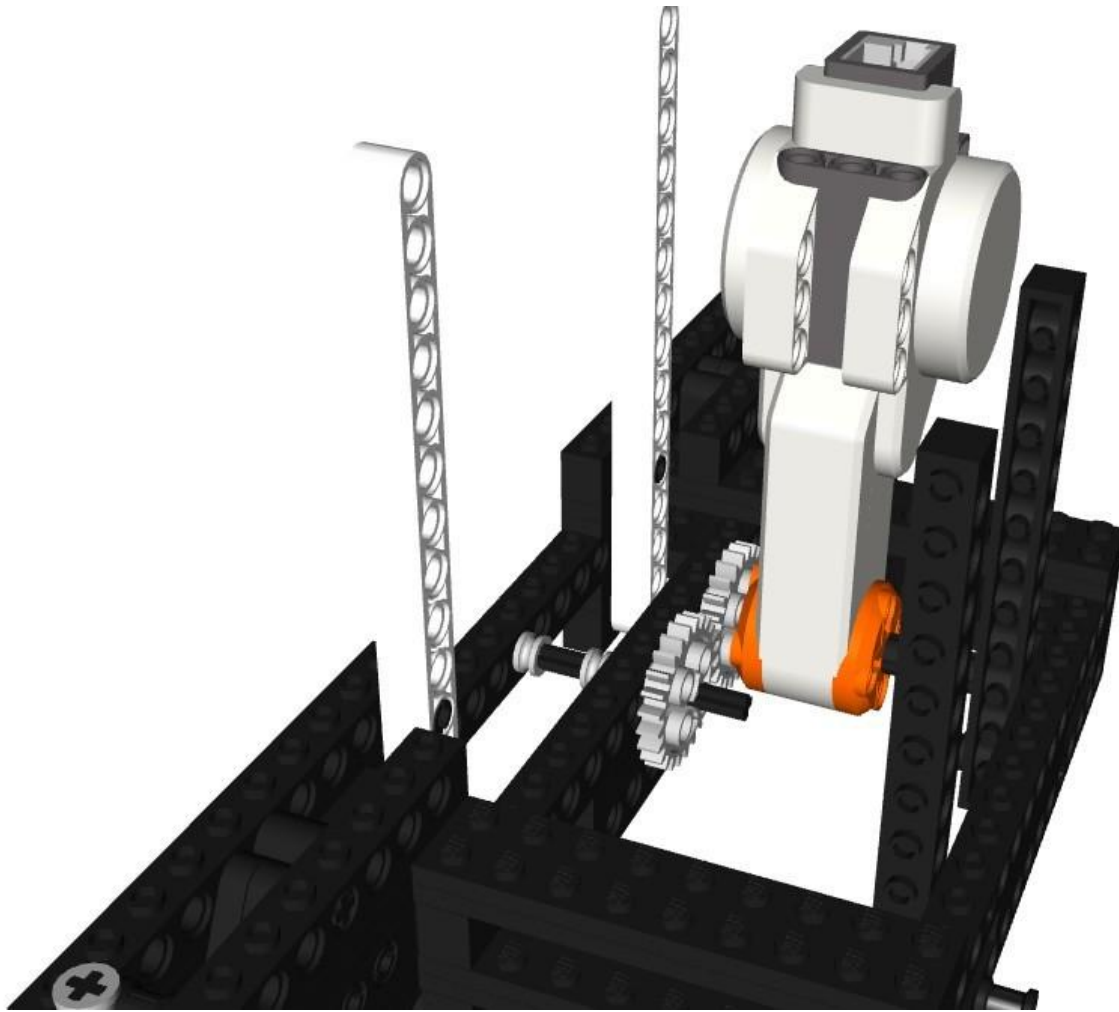

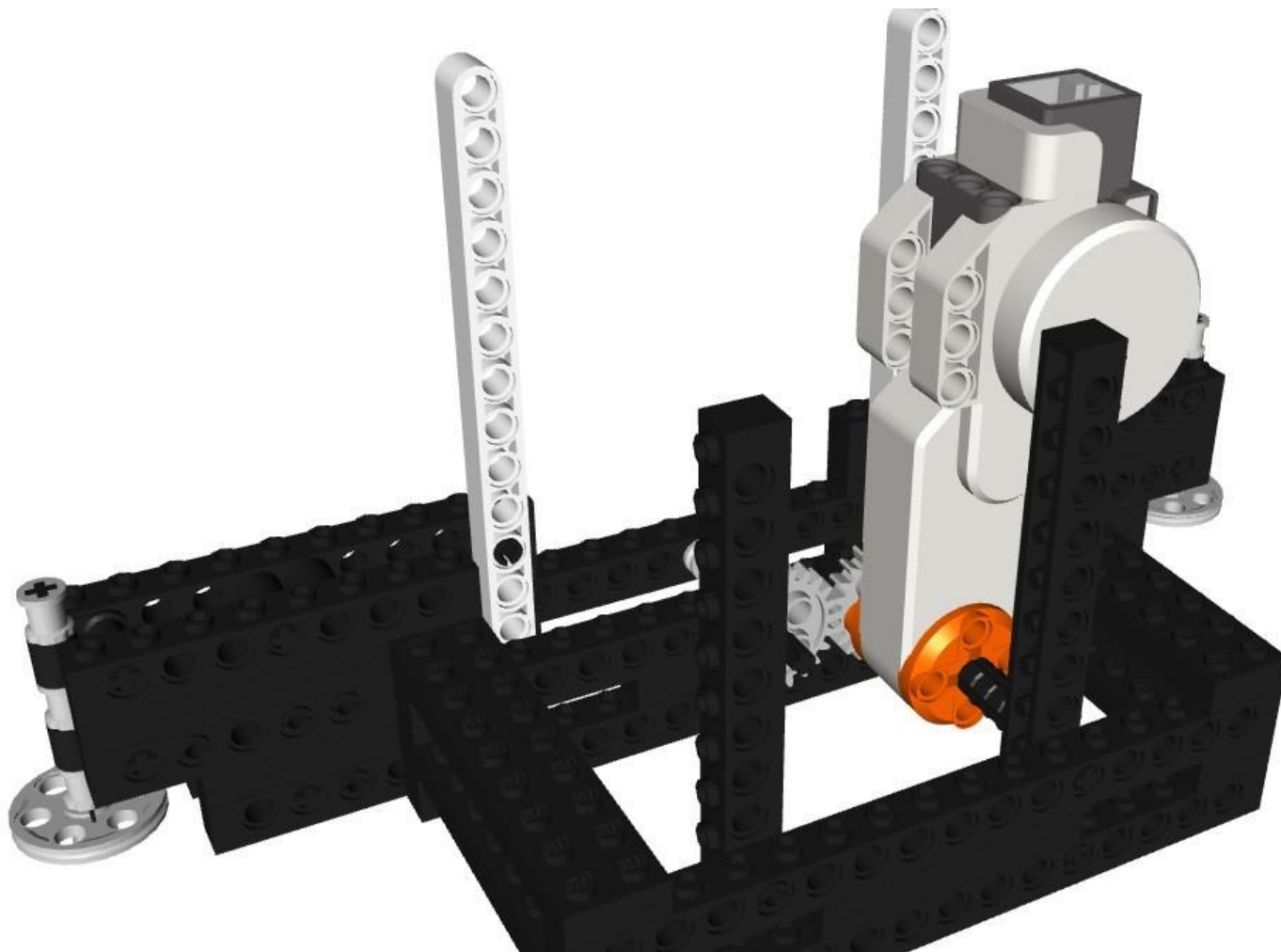

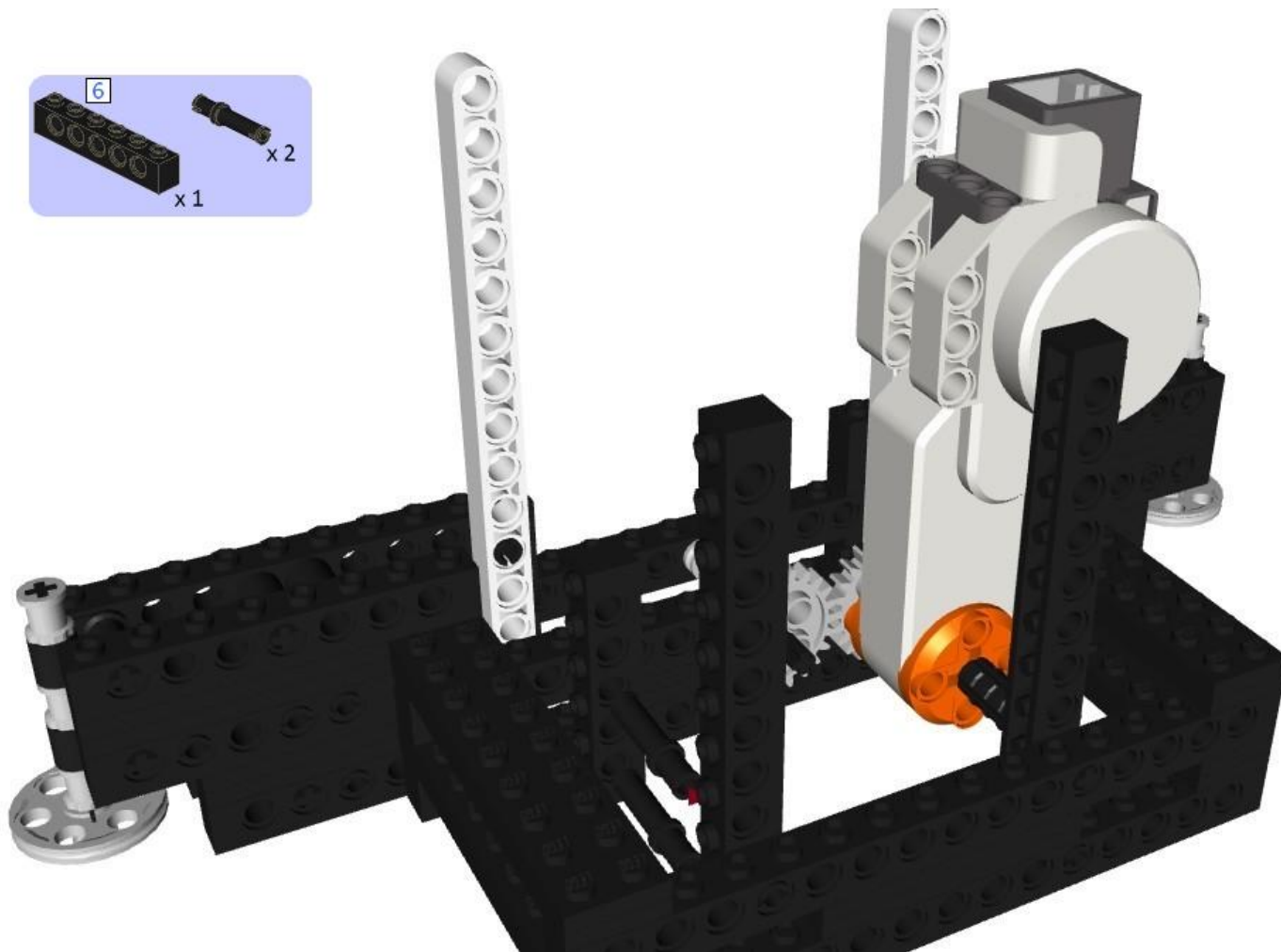
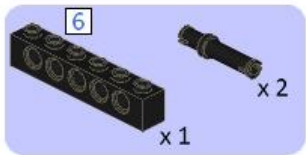

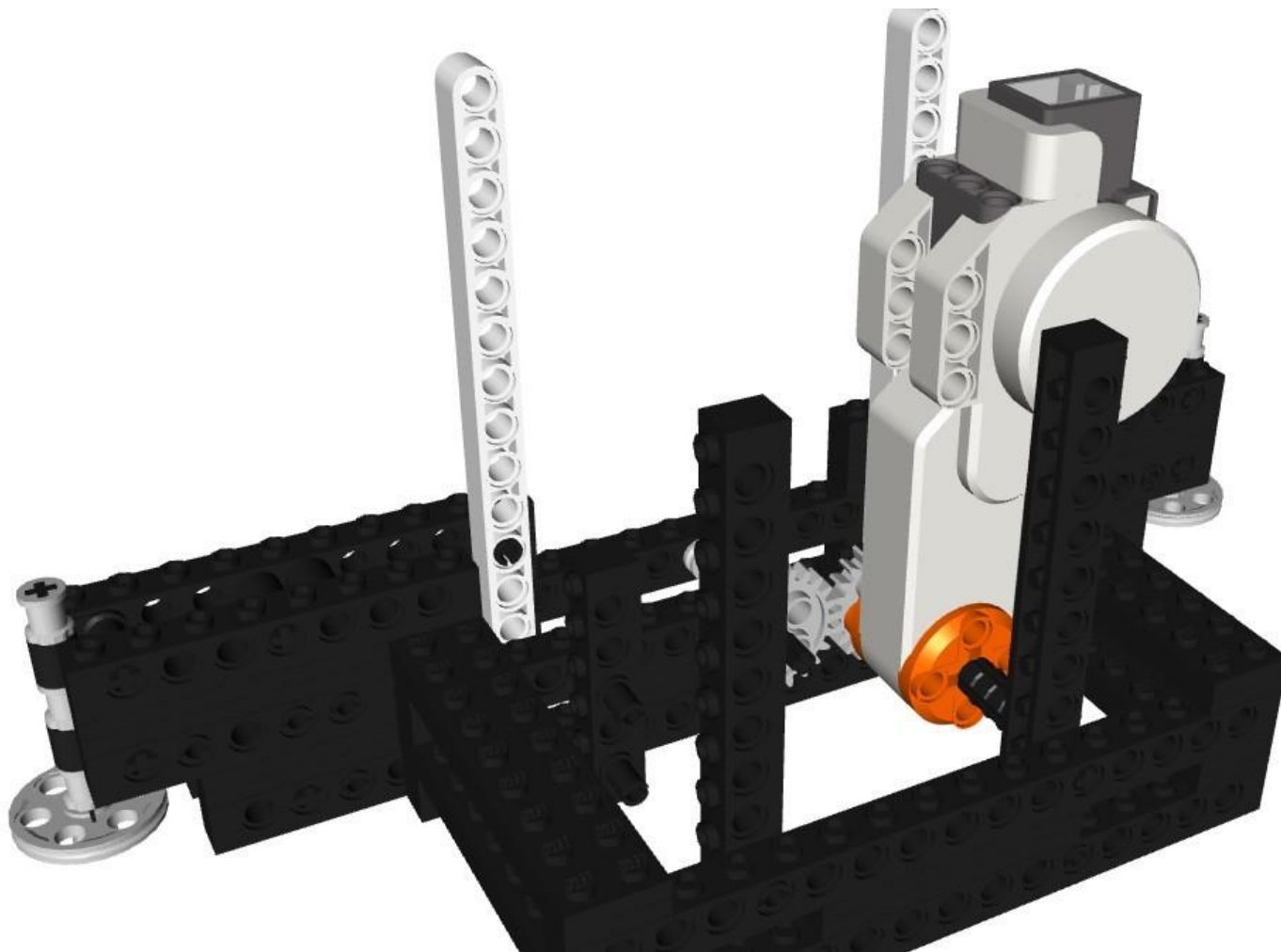

70/147

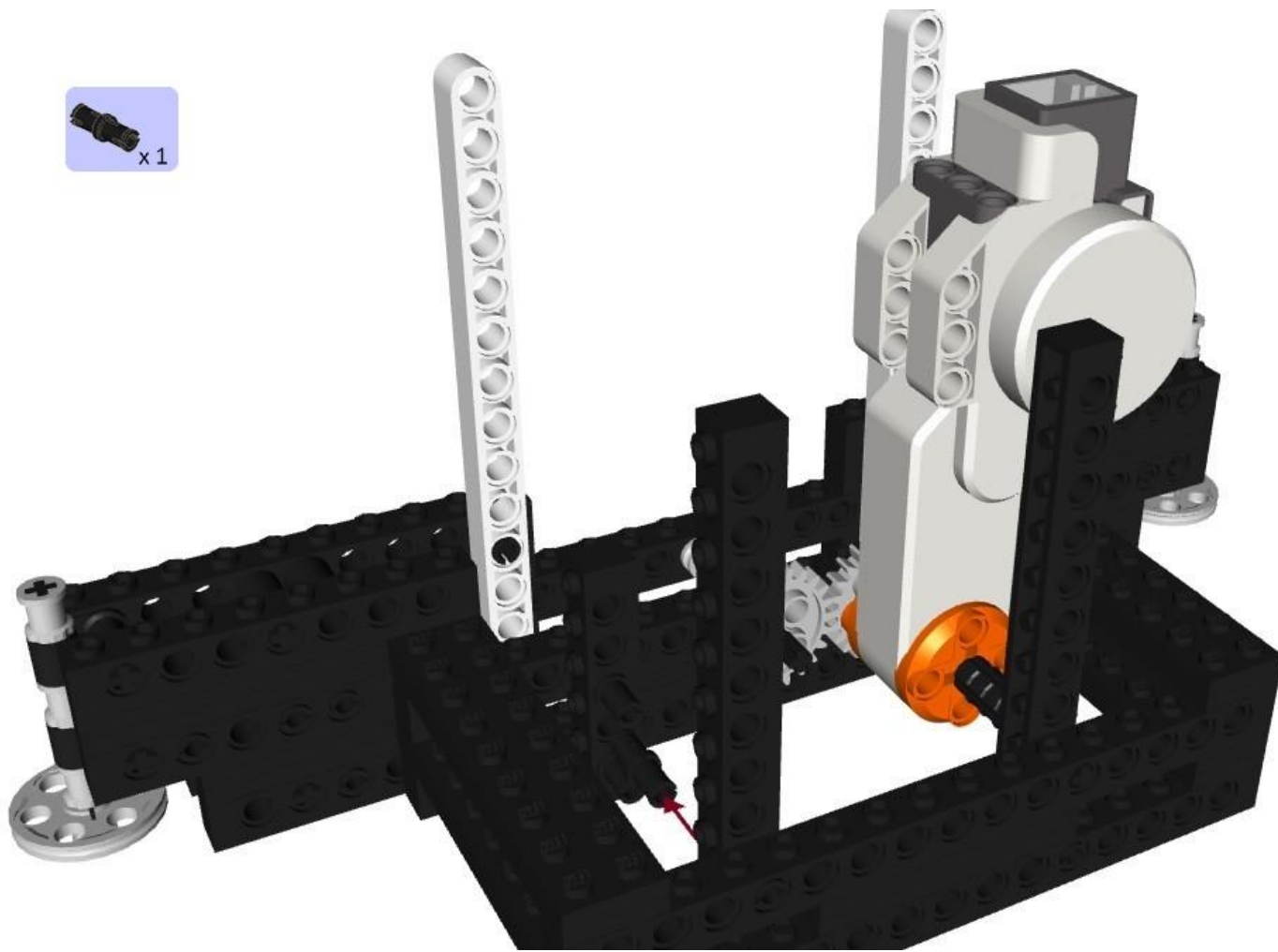

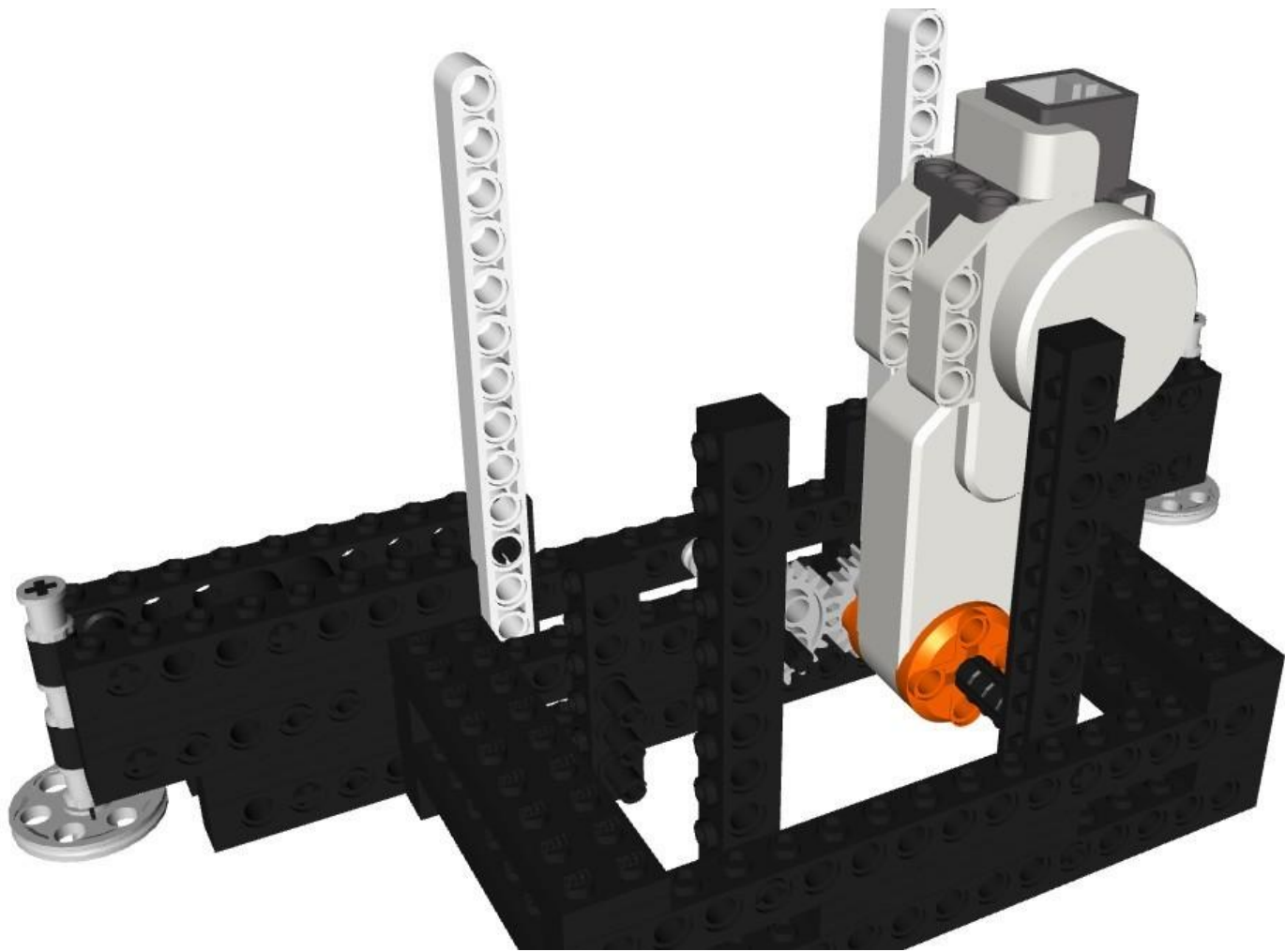

72/147

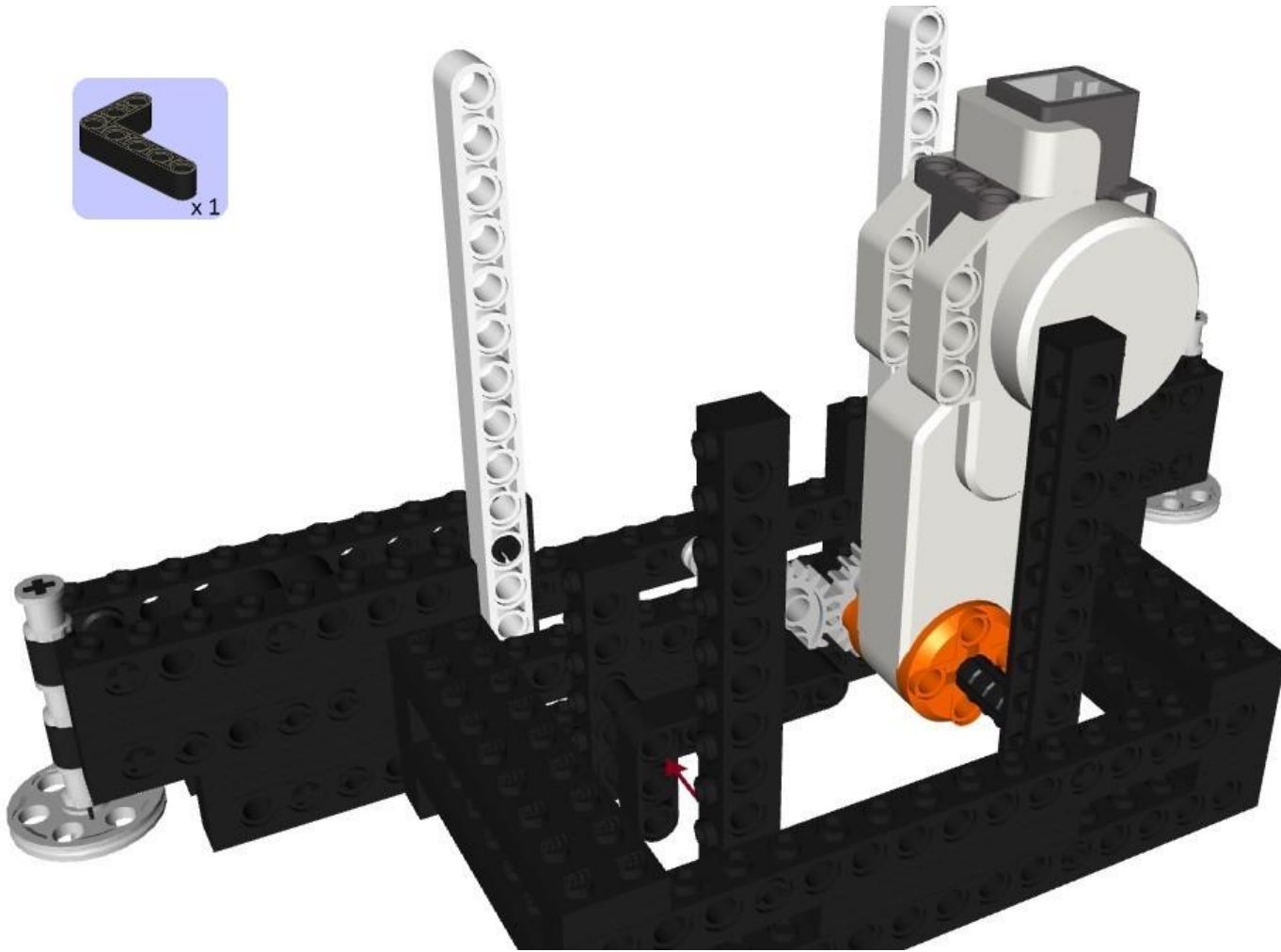
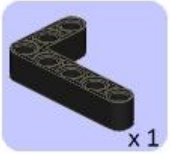

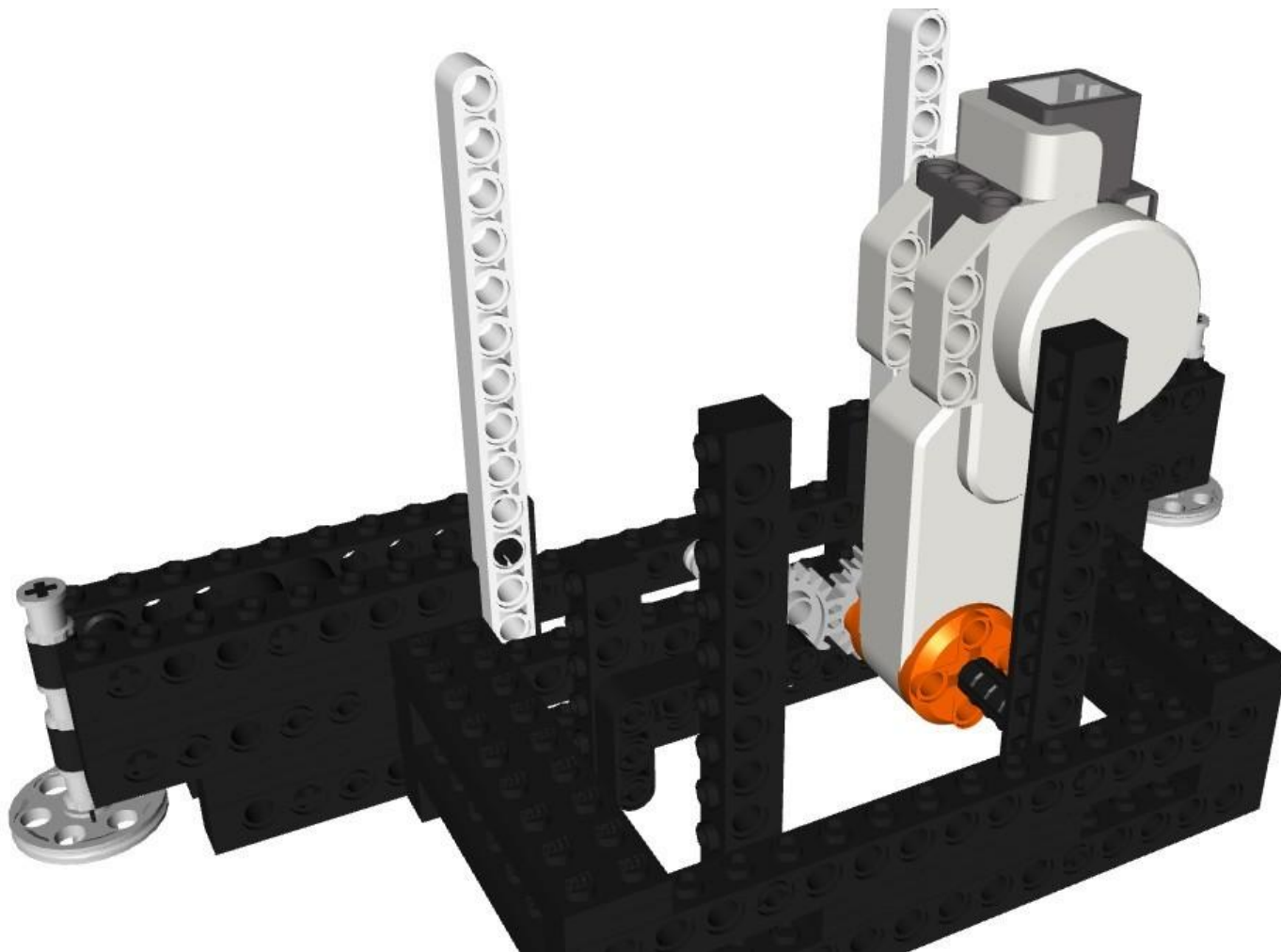

74/147

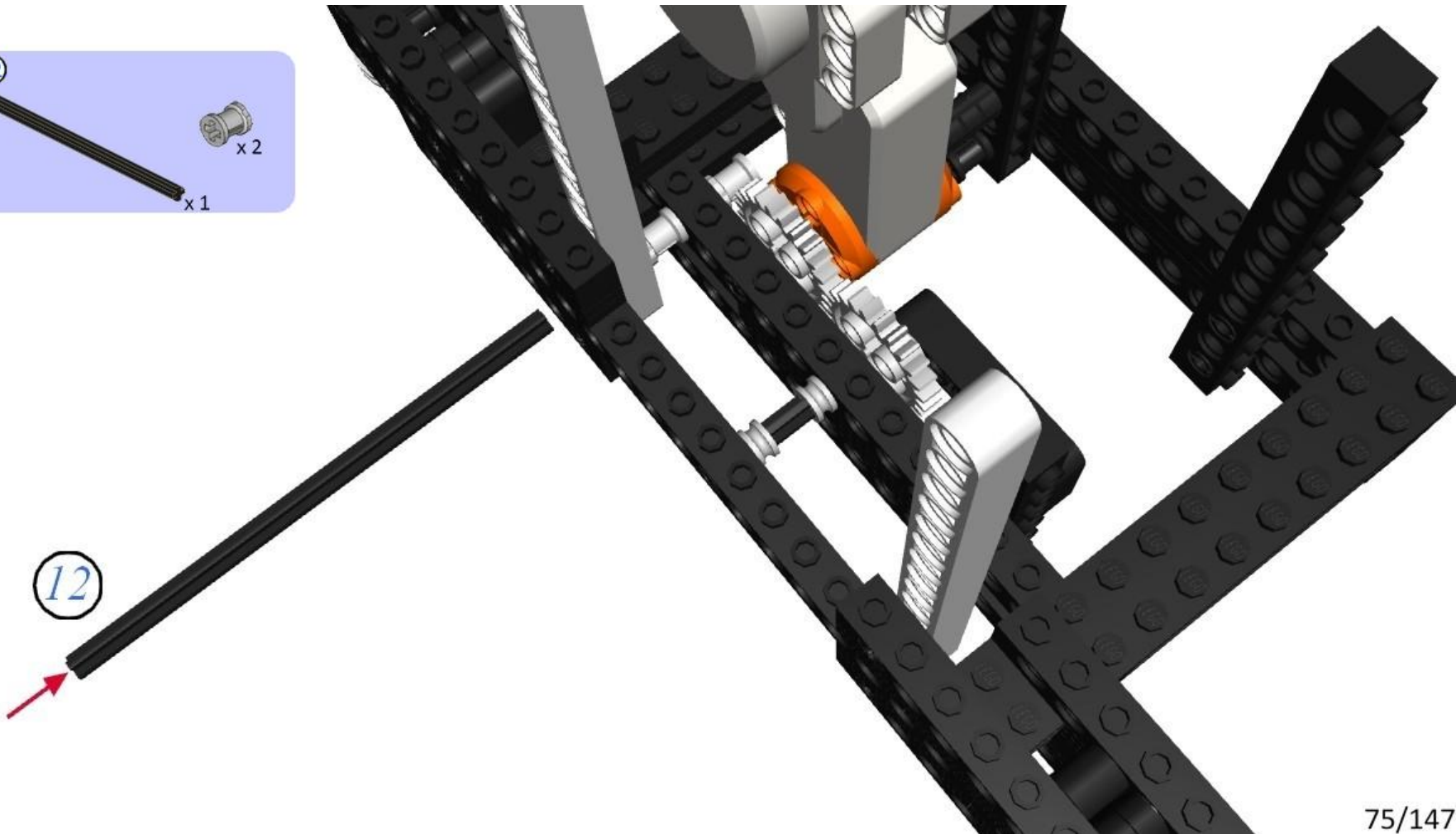

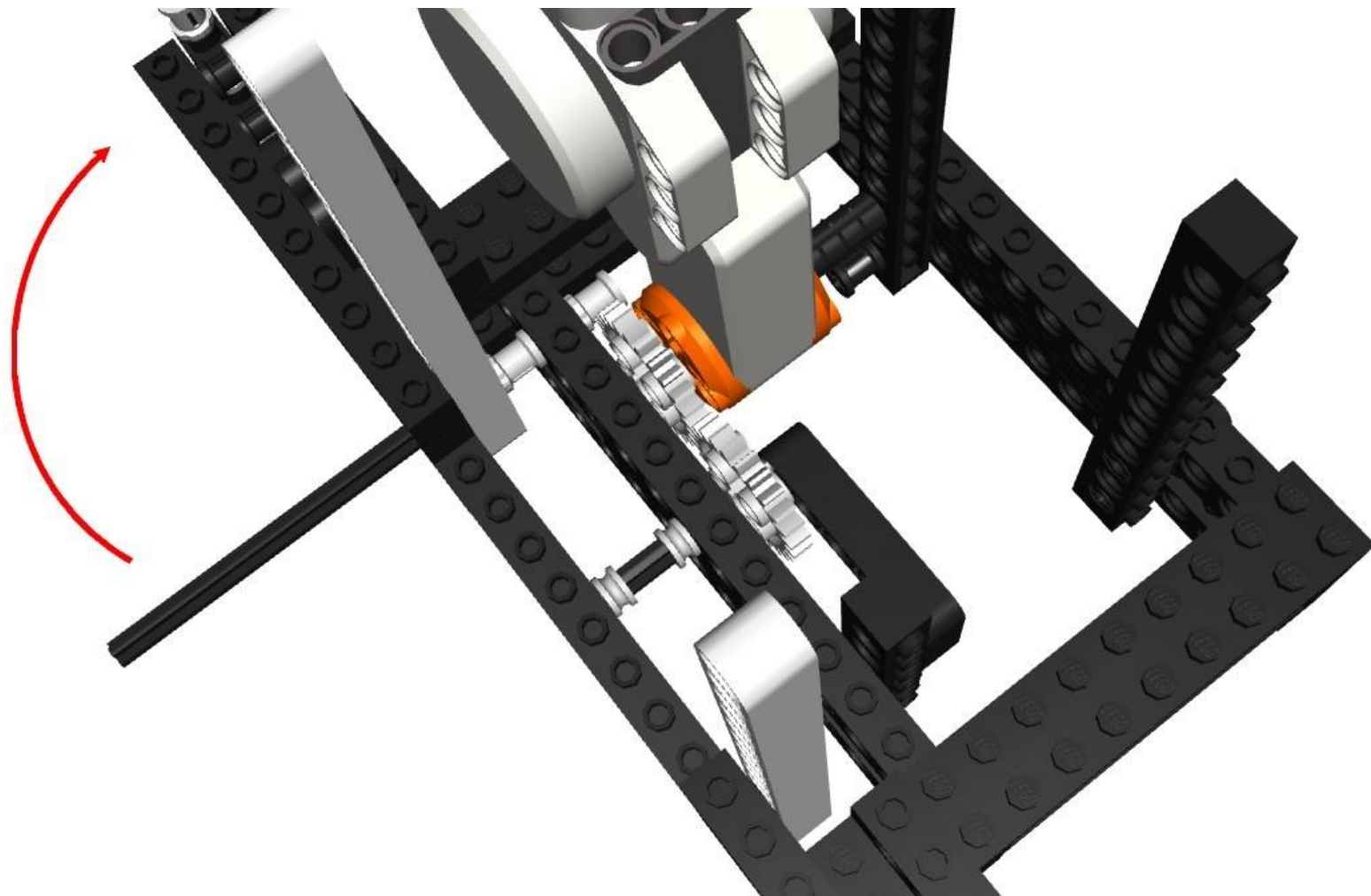

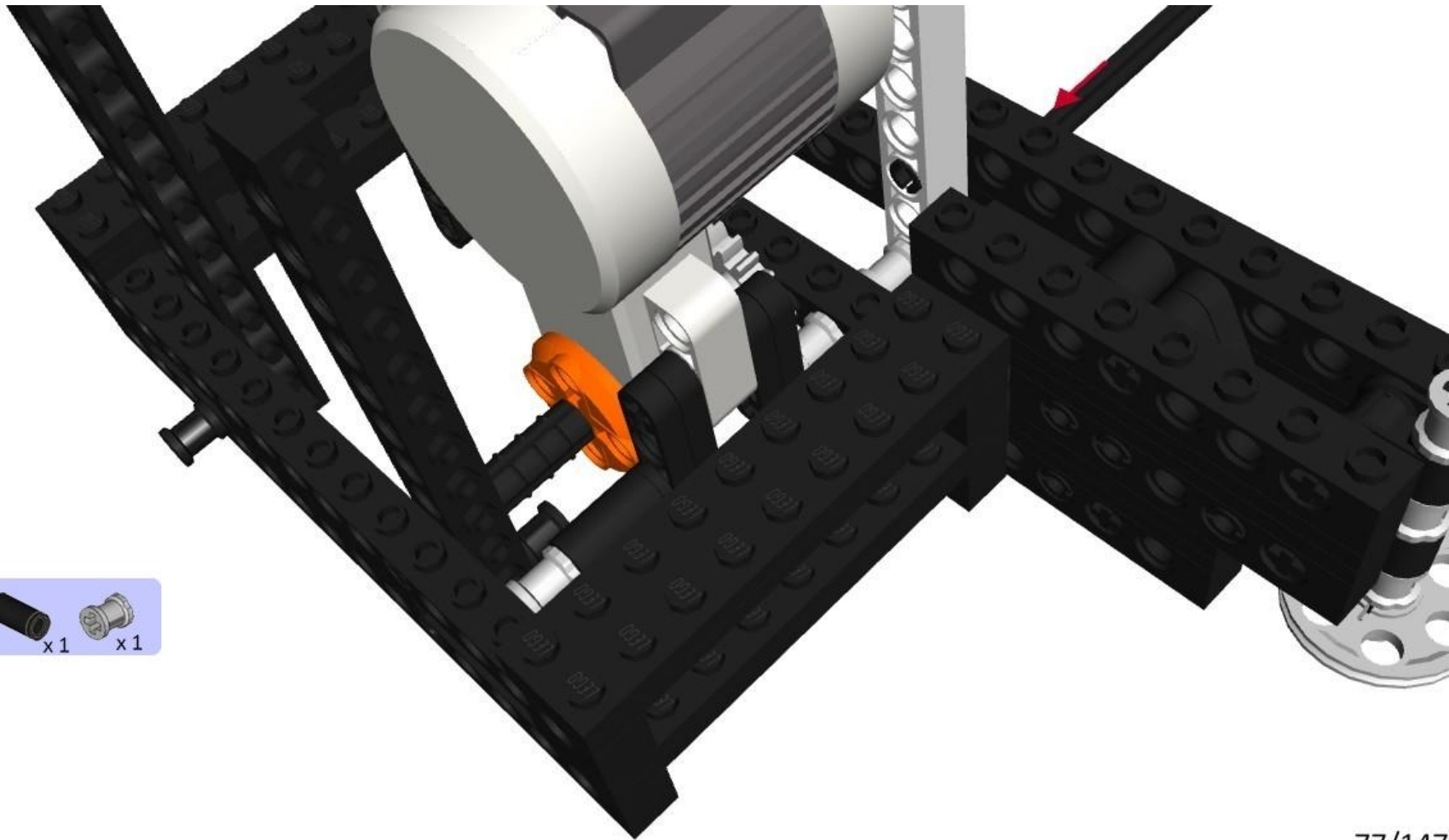

77/147

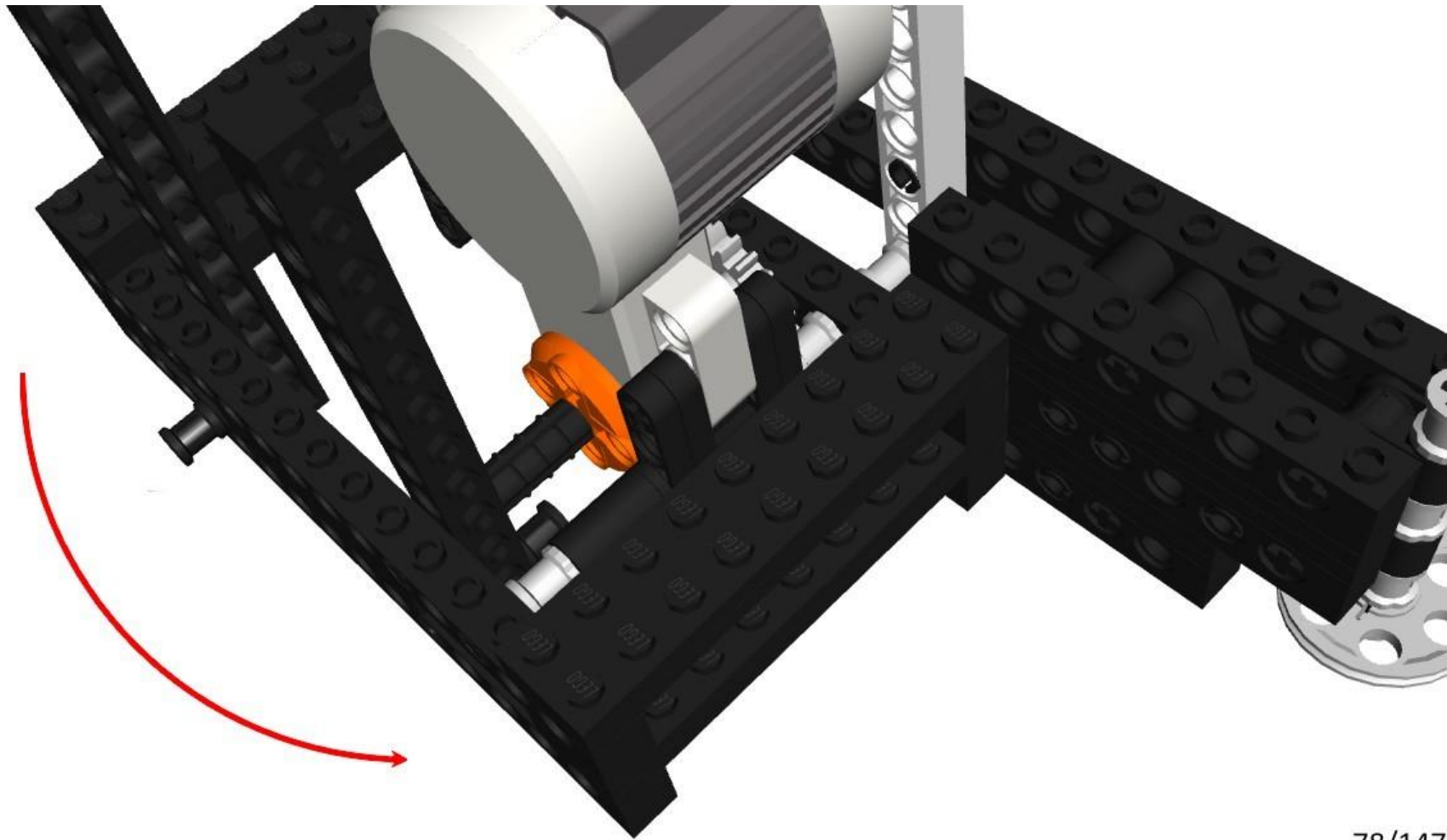

78/147

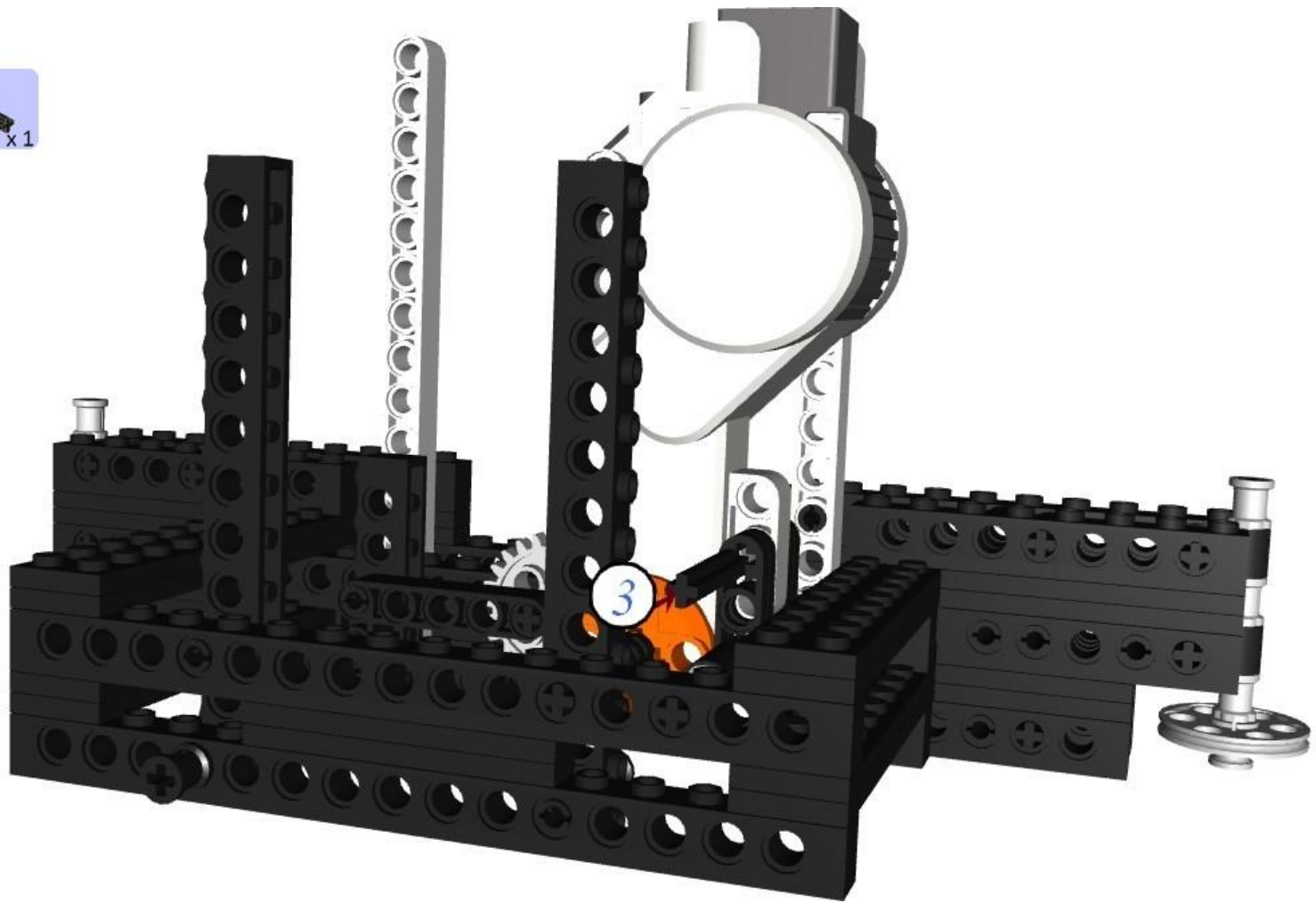

79/147

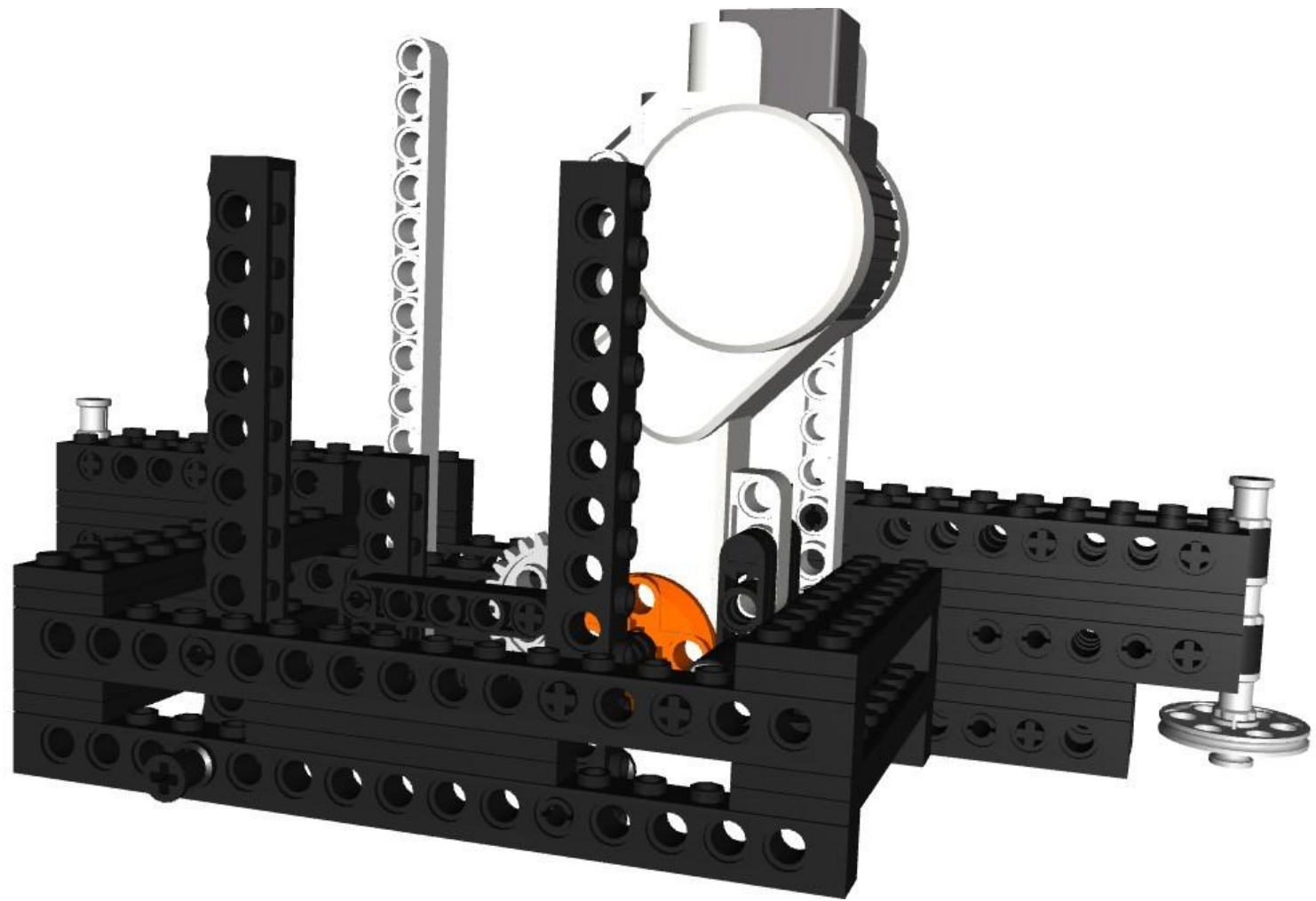

80/147

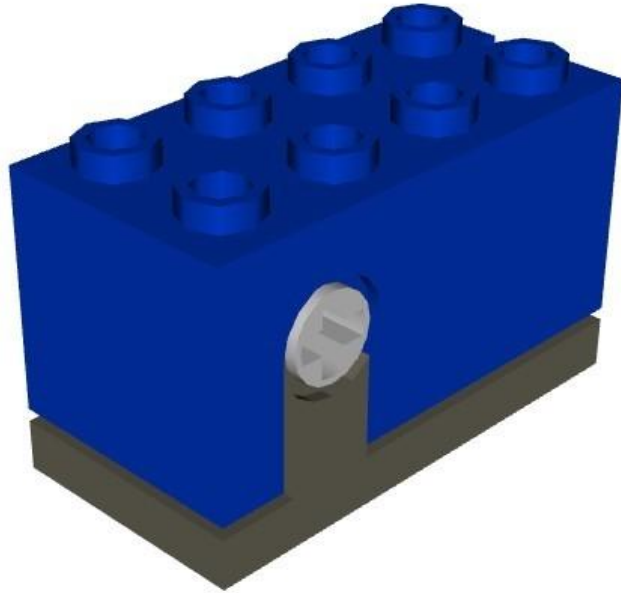

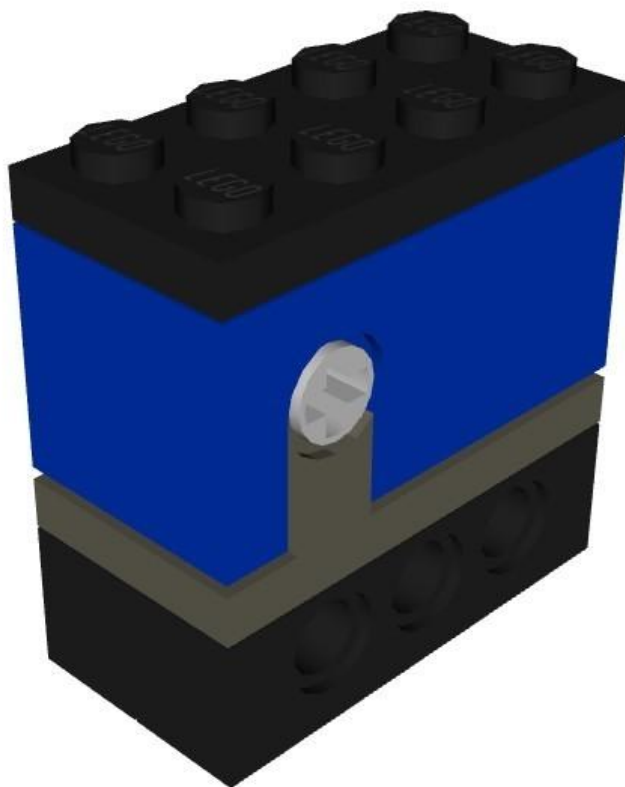
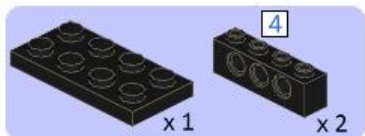

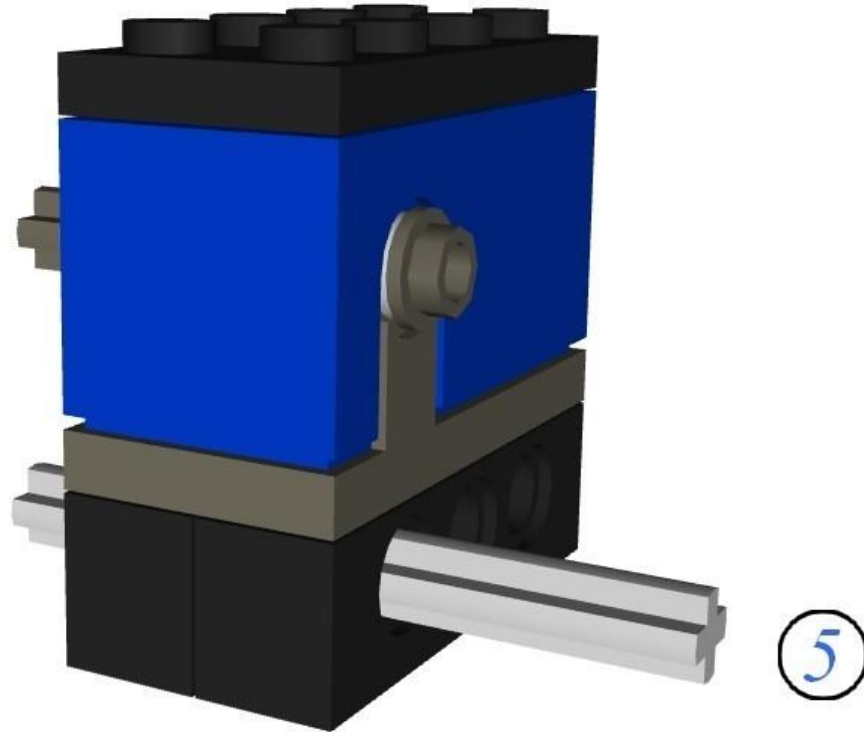
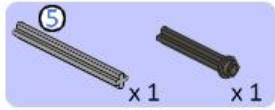

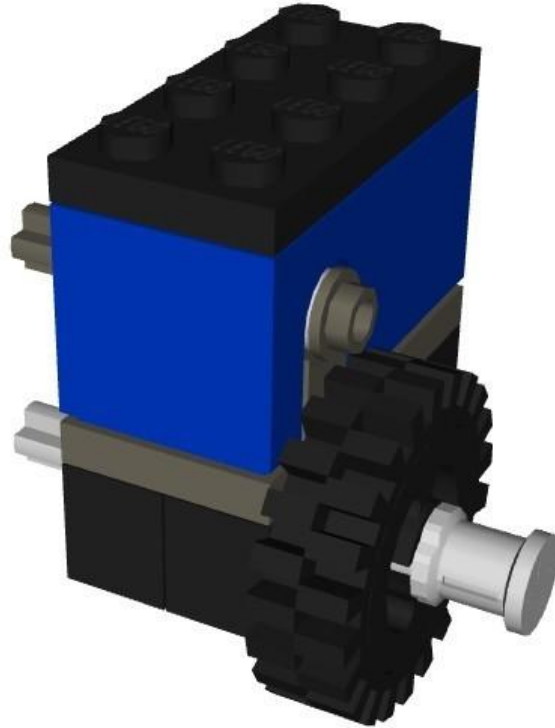
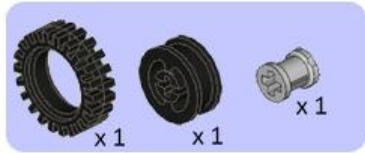

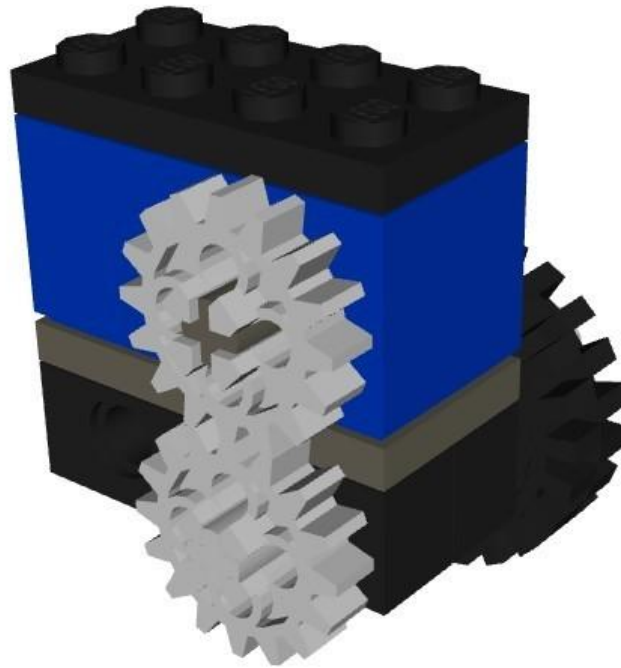

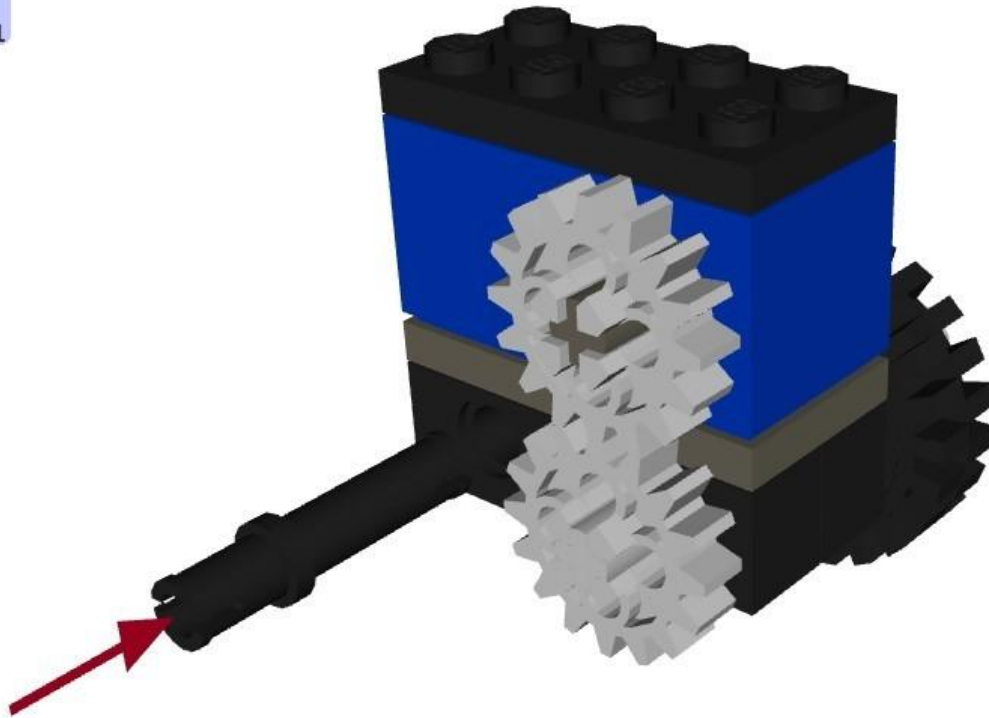

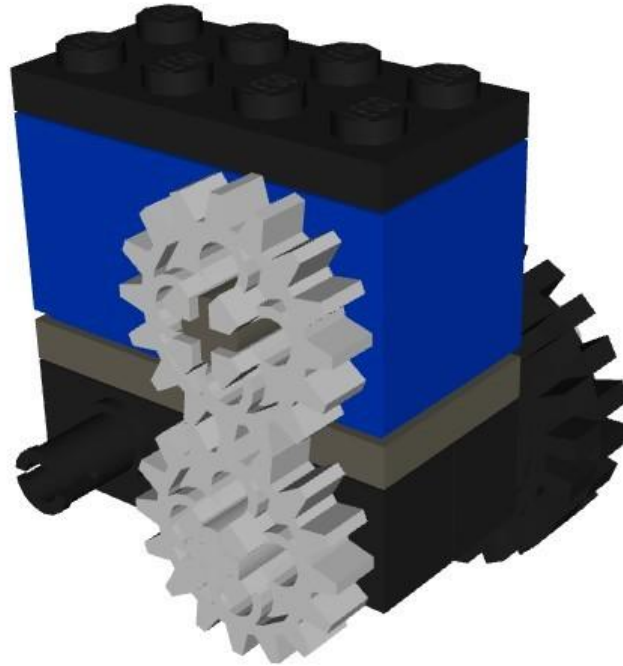

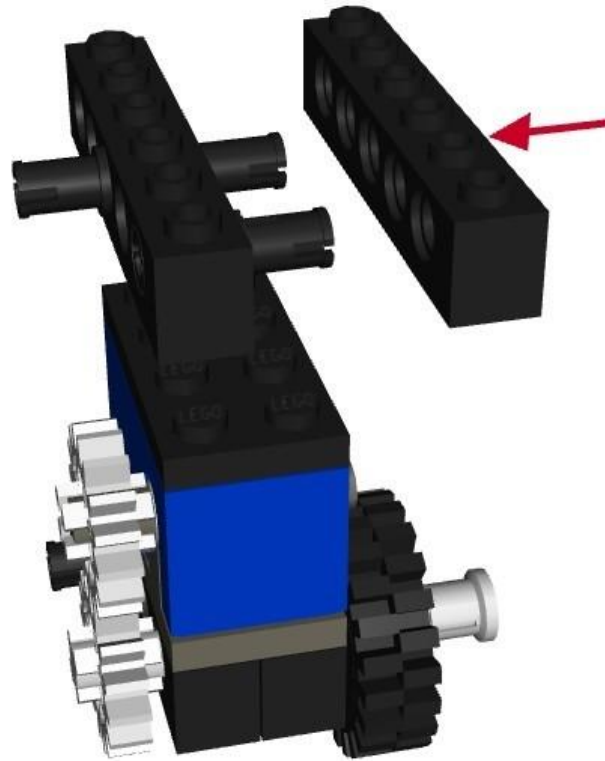
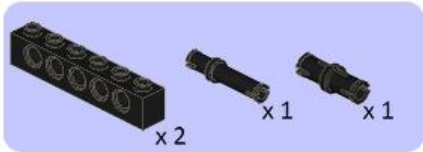

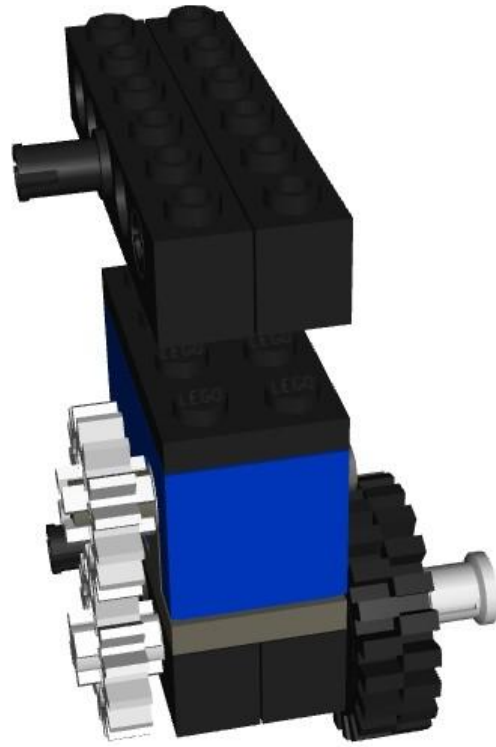

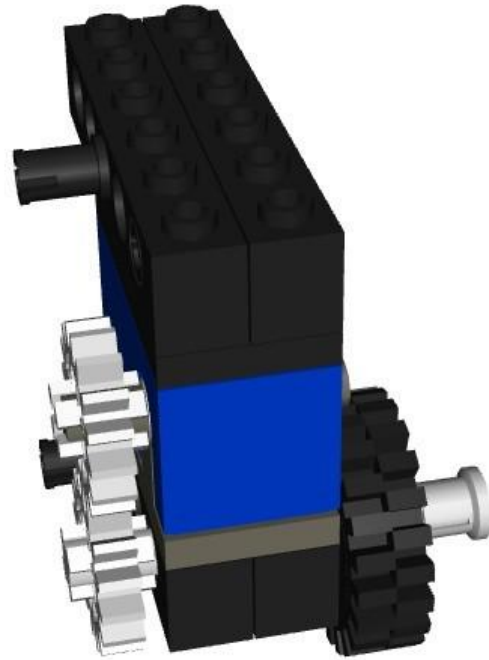

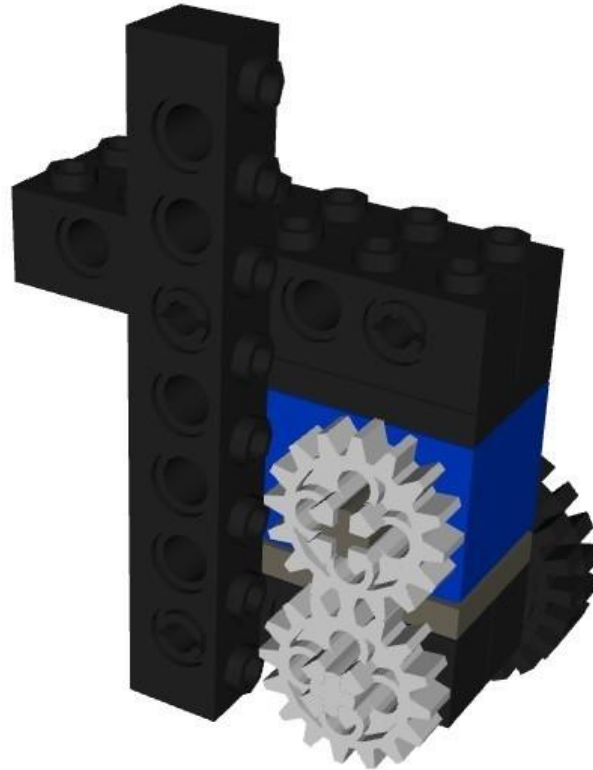
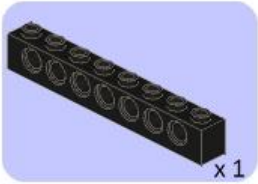

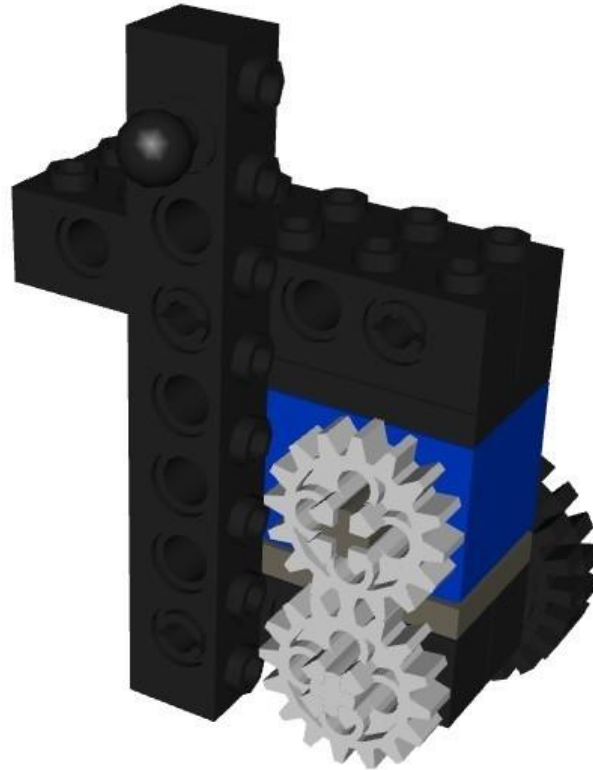

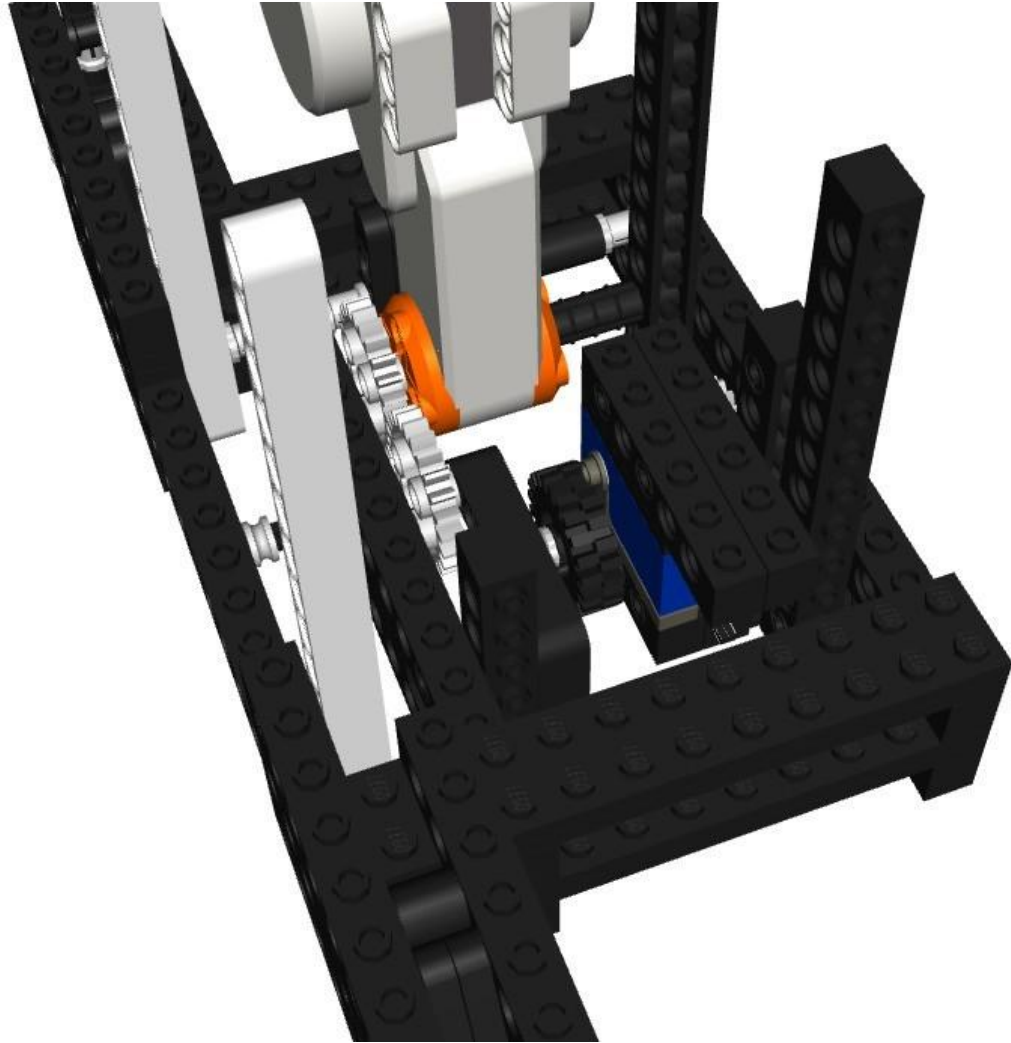

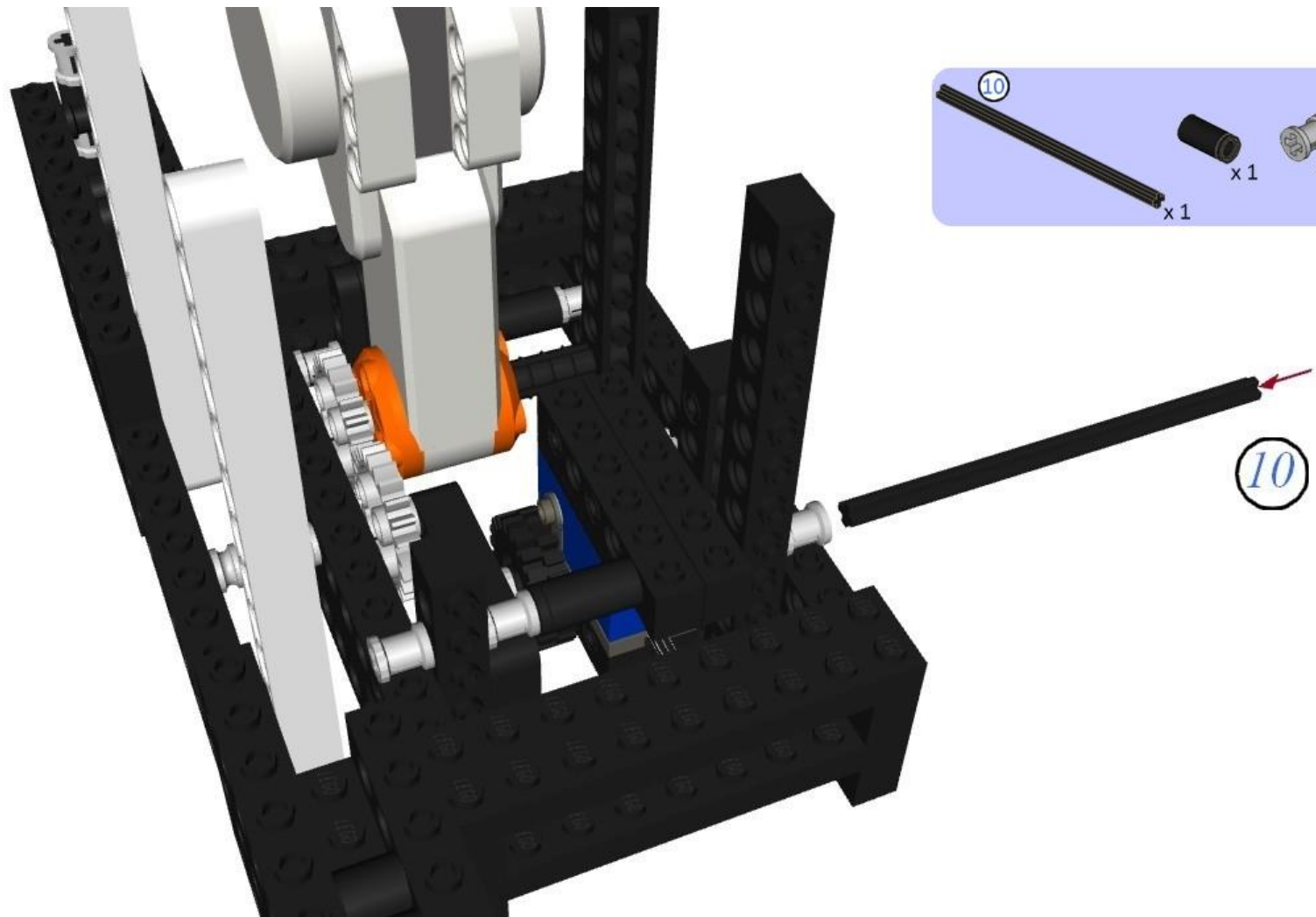

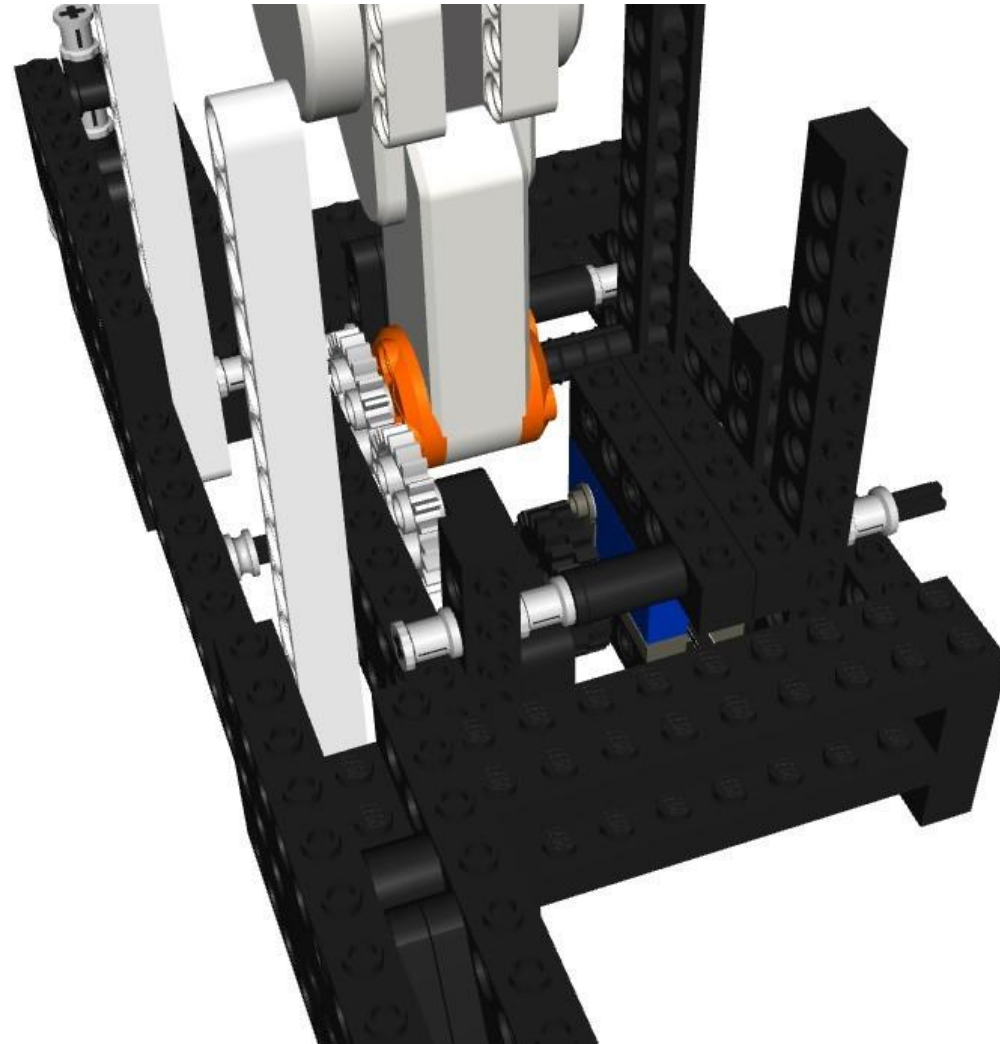

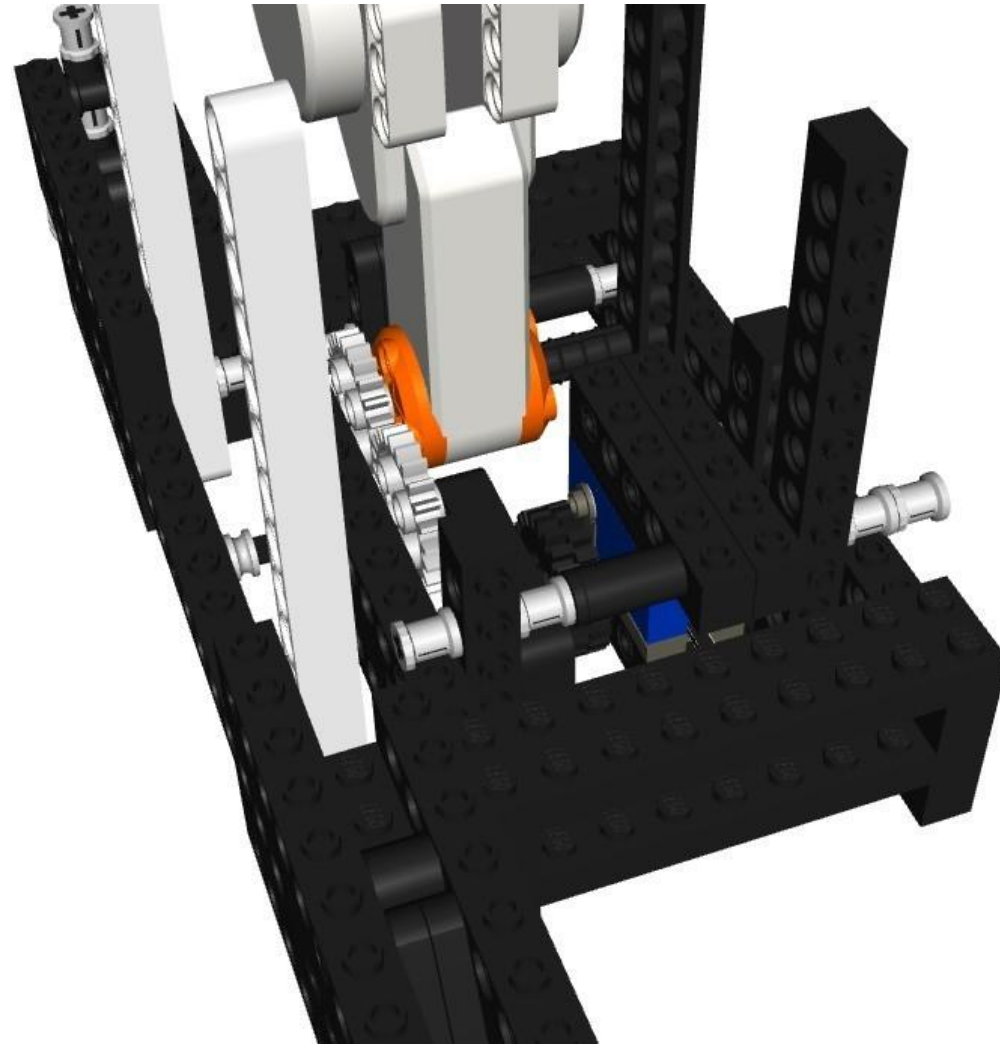

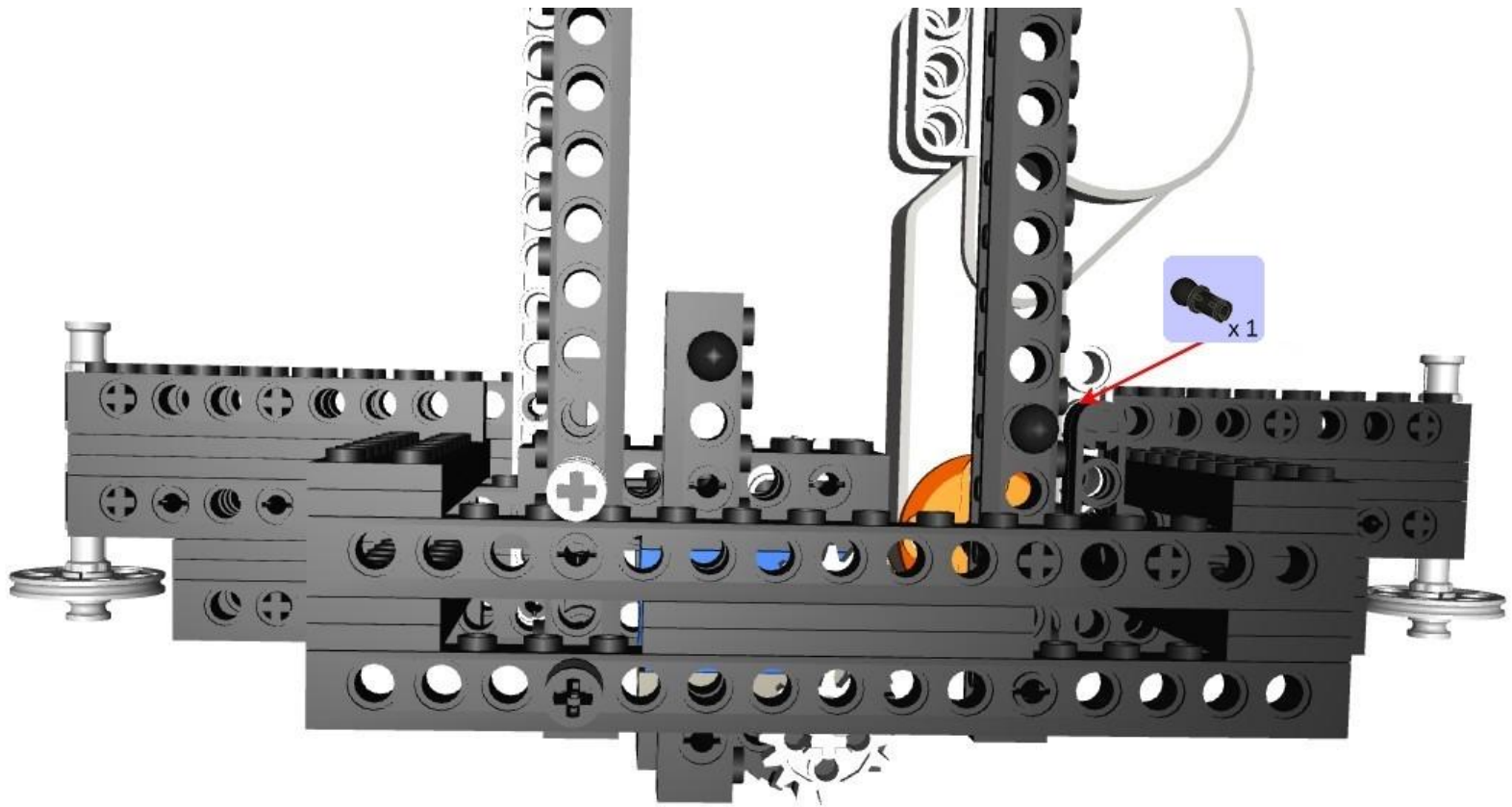



Mettre un élastique bleu  x1 qui rejoint les deux  x1

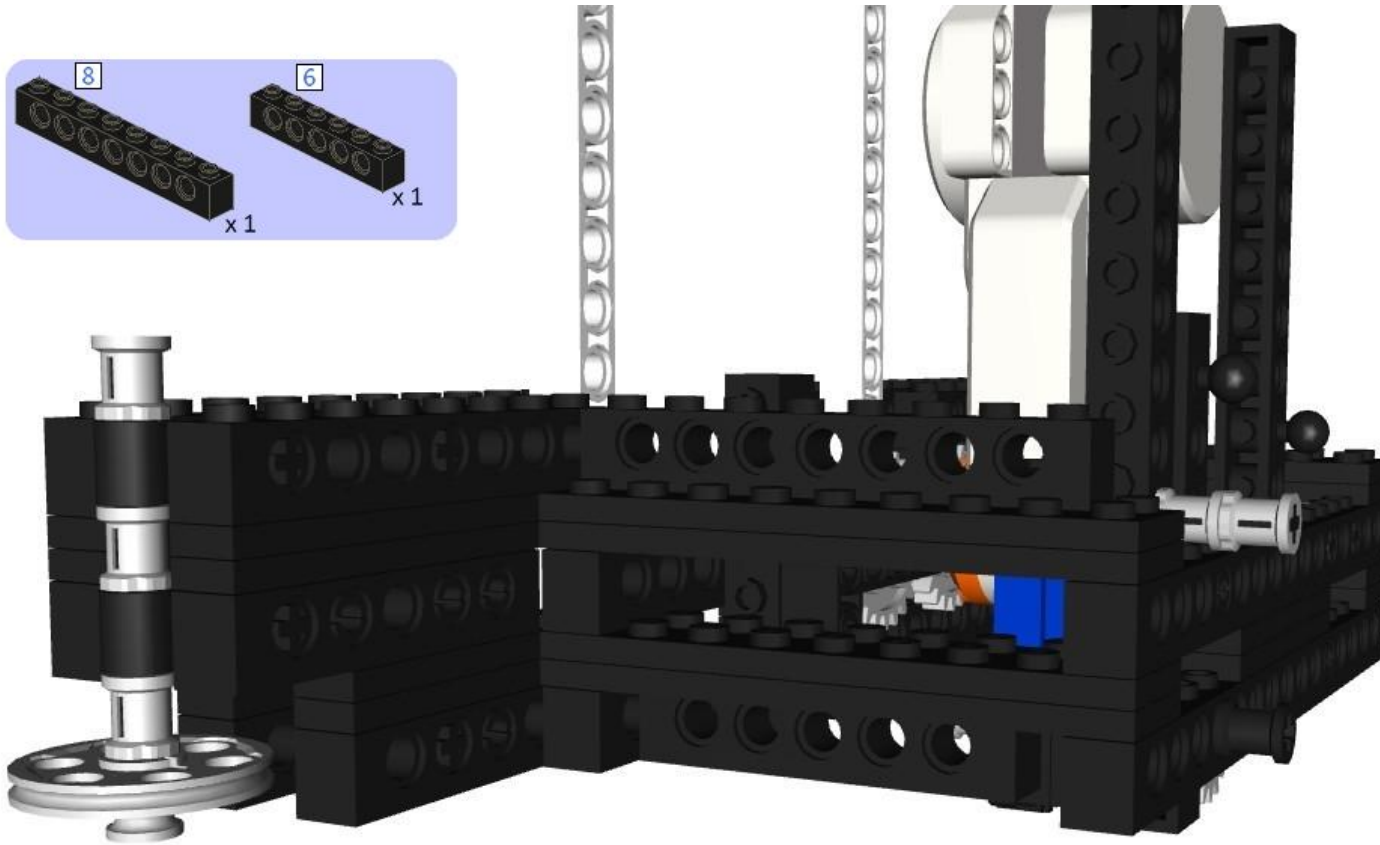
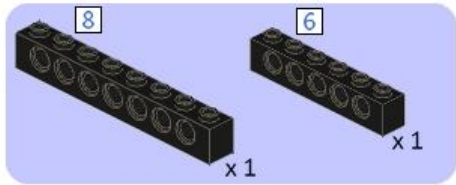

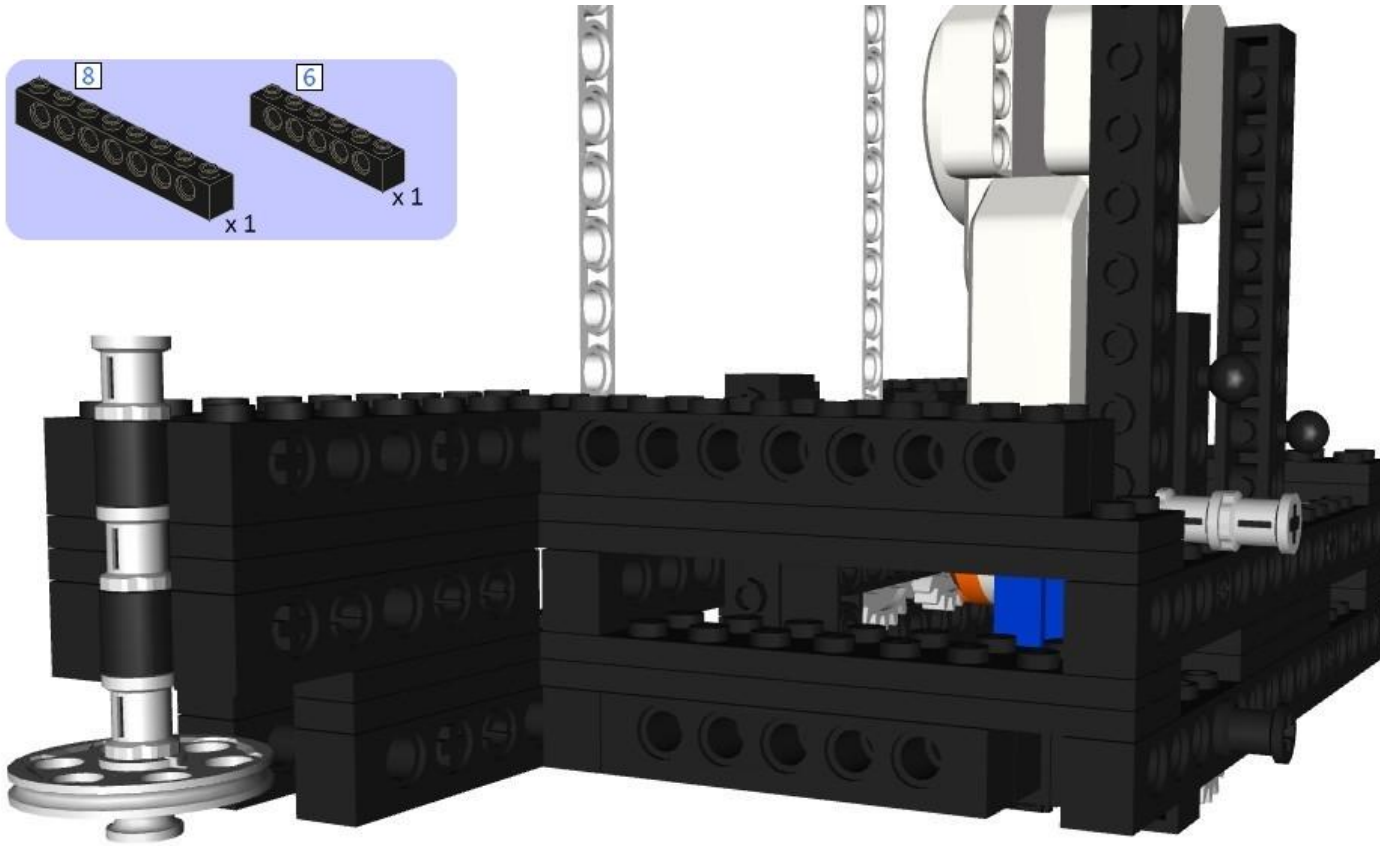
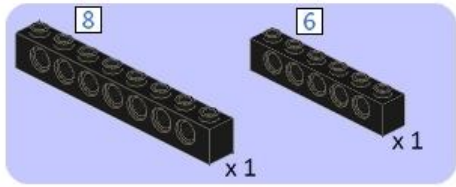

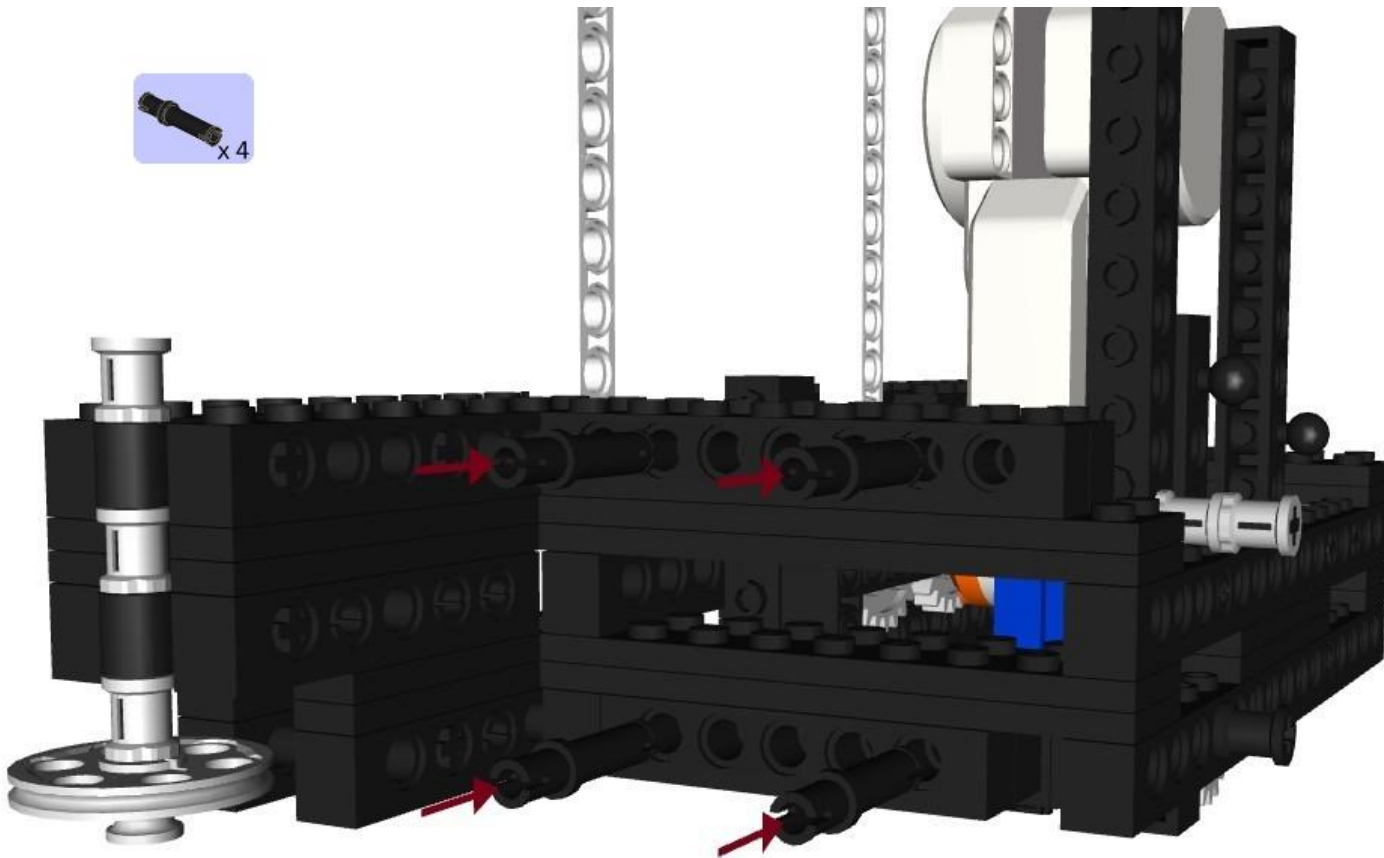

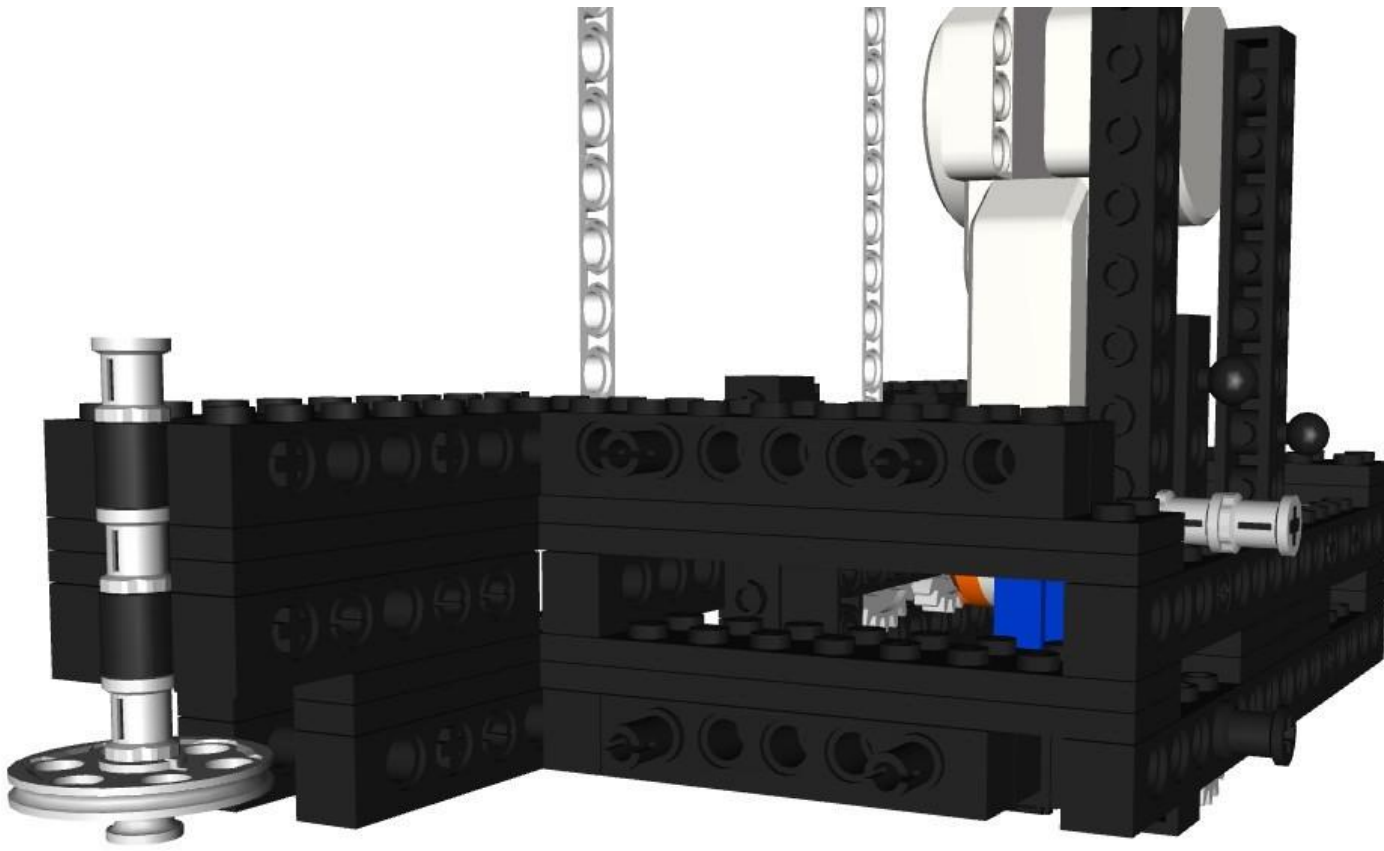

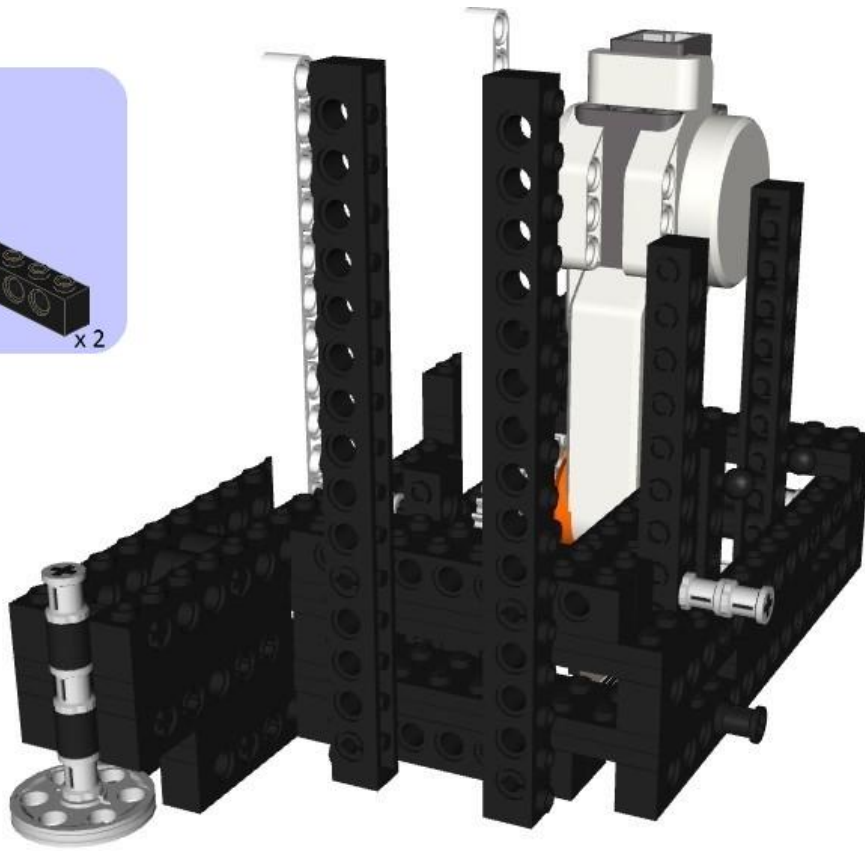
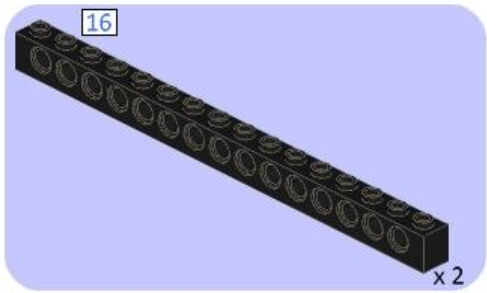

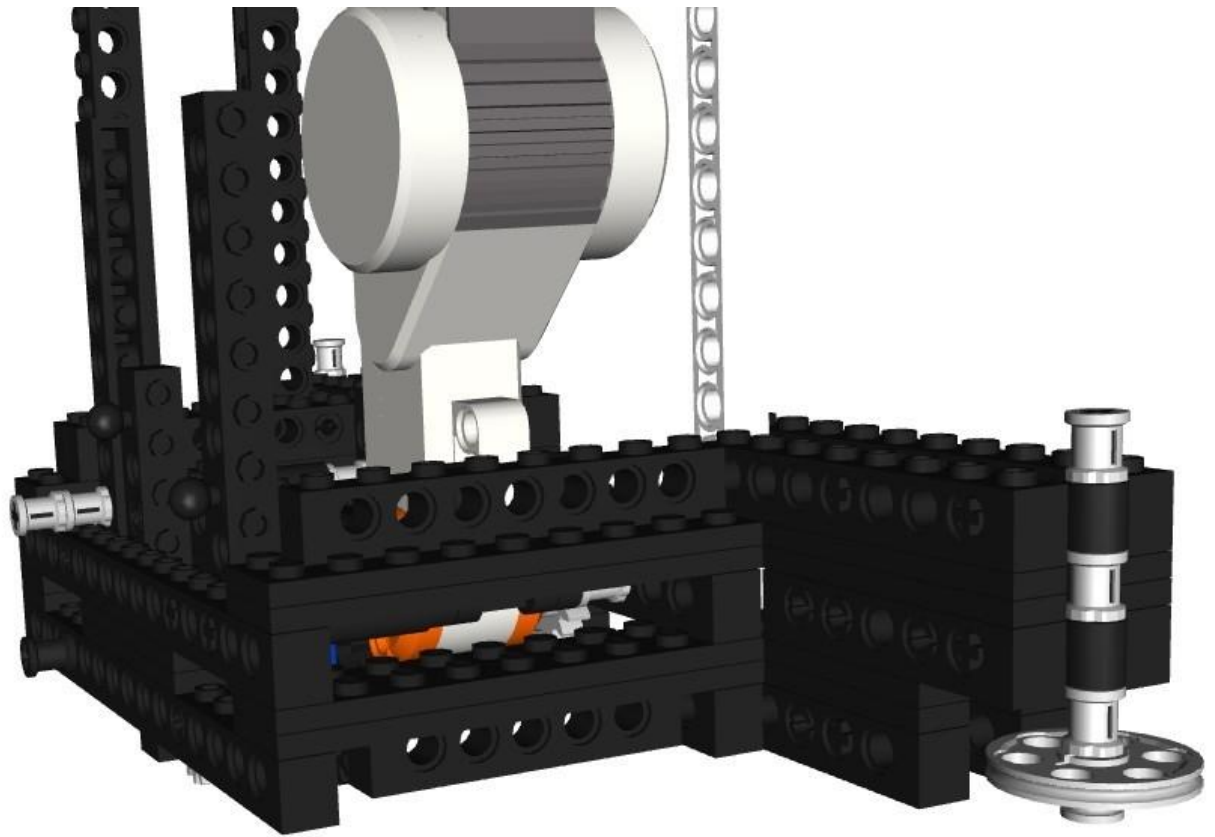
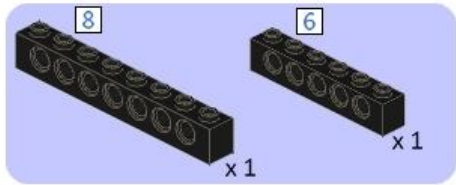

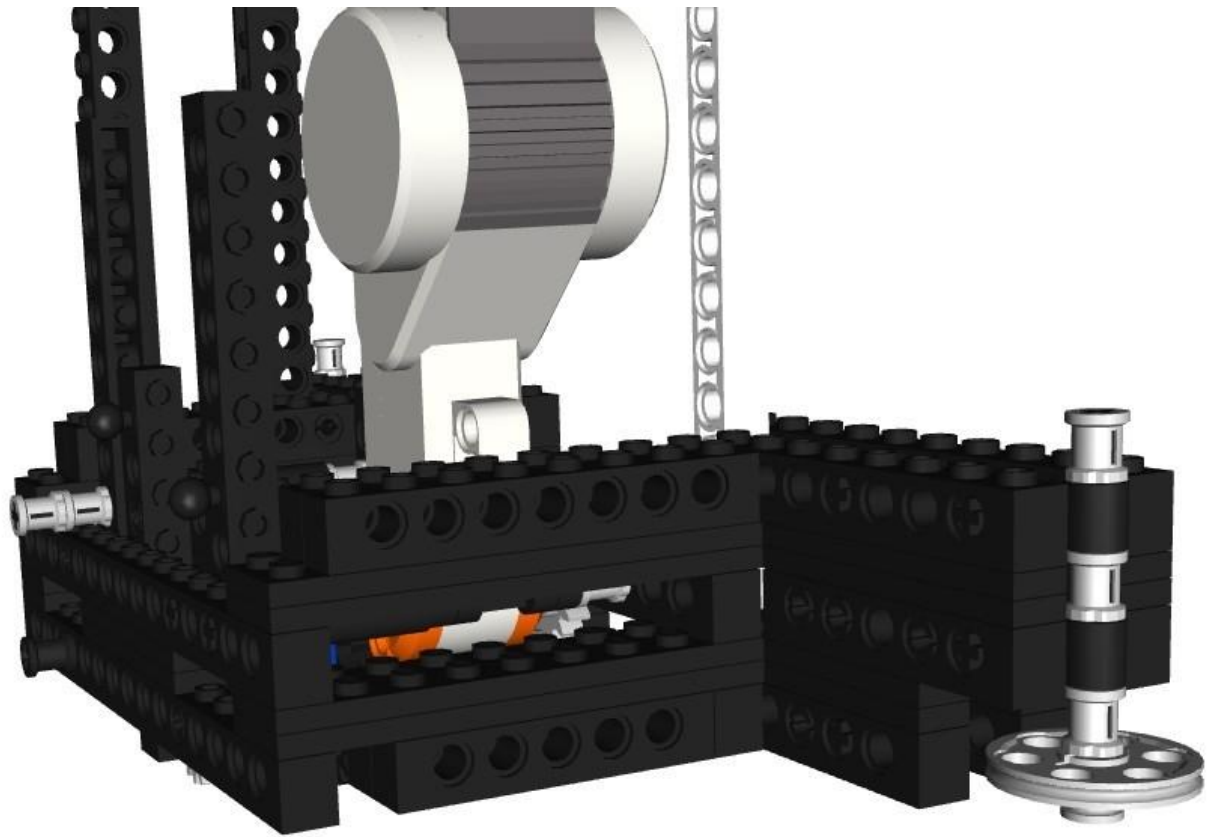
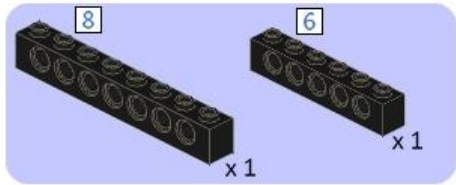

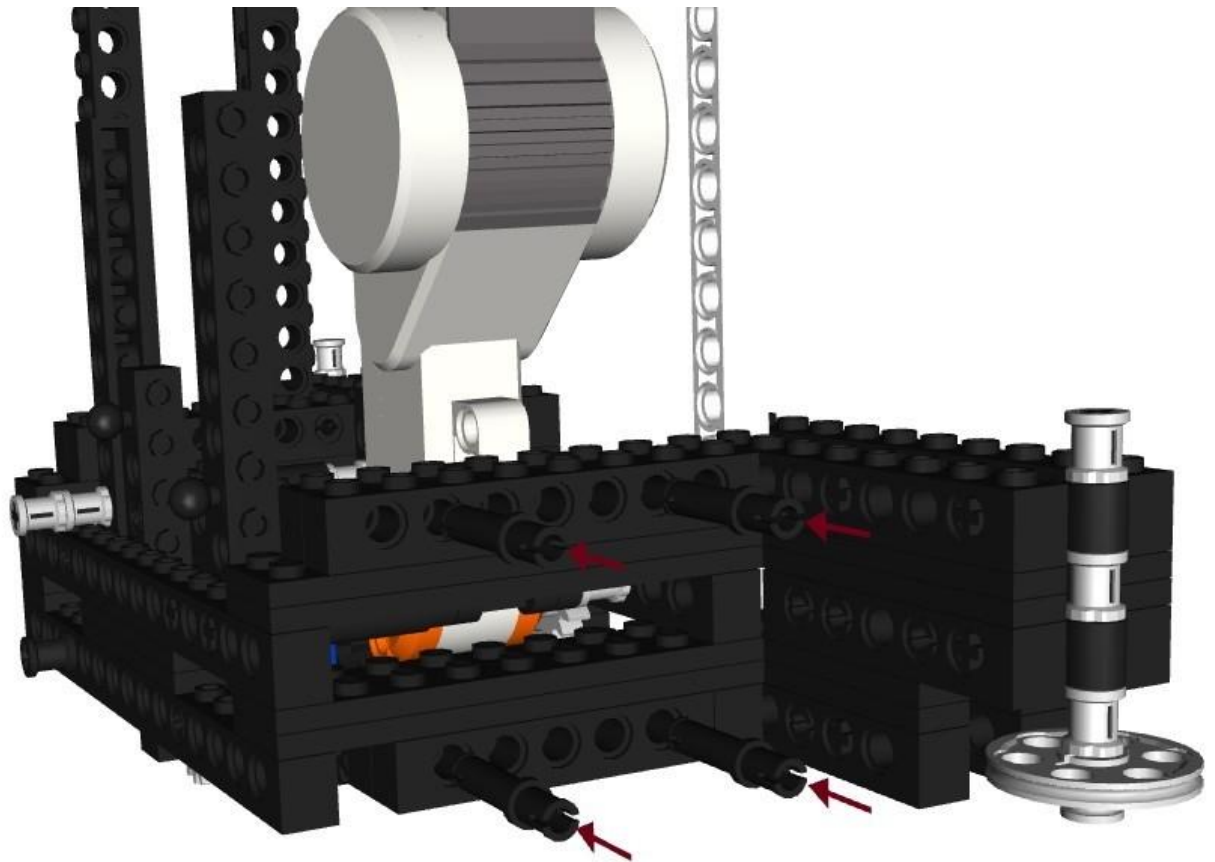

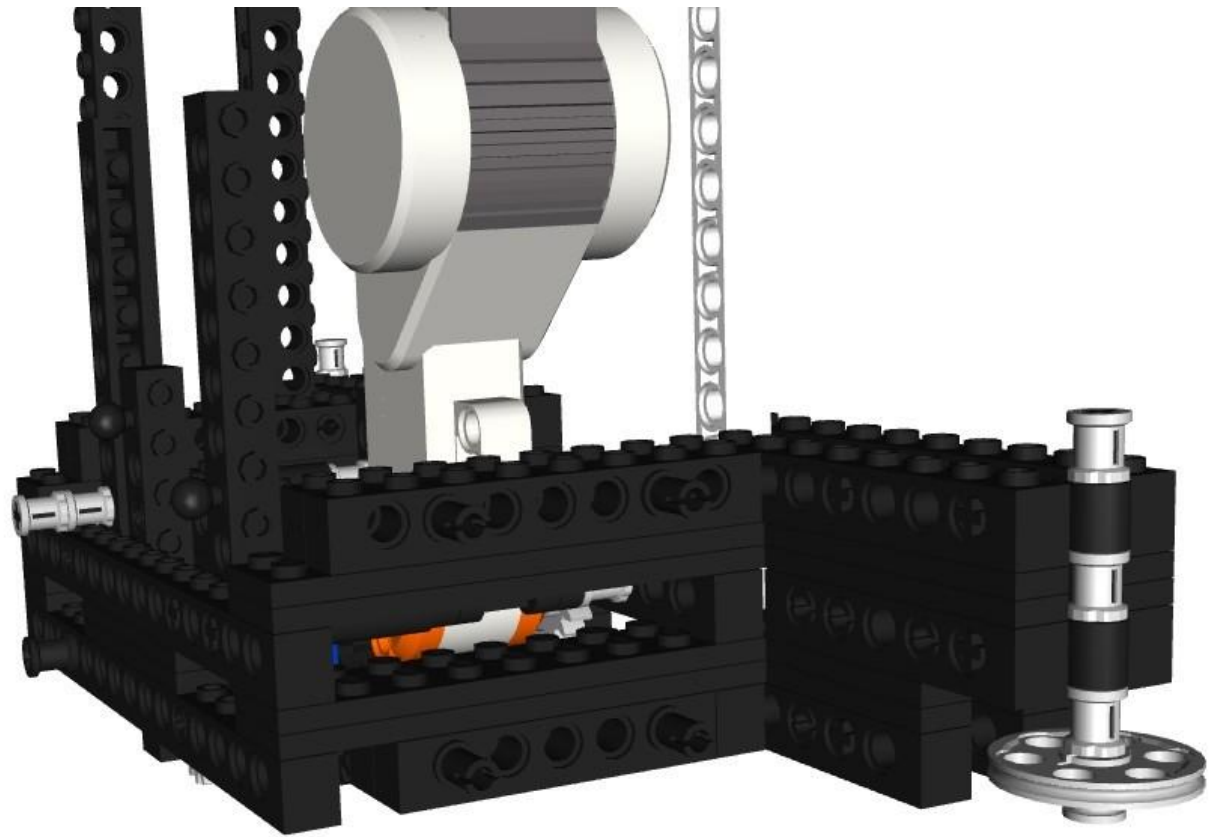

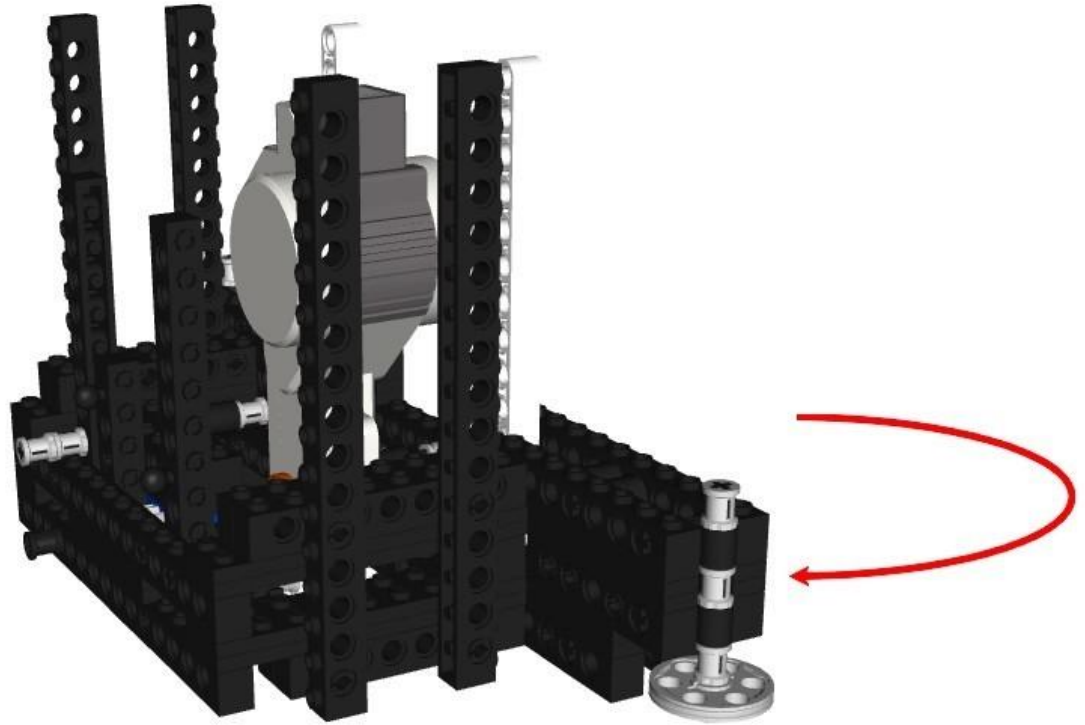
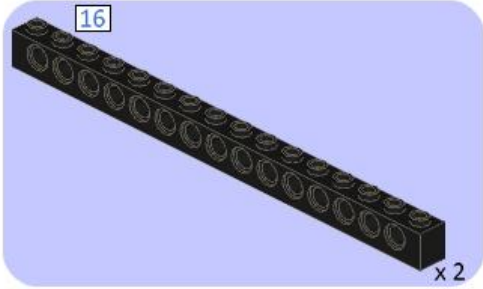

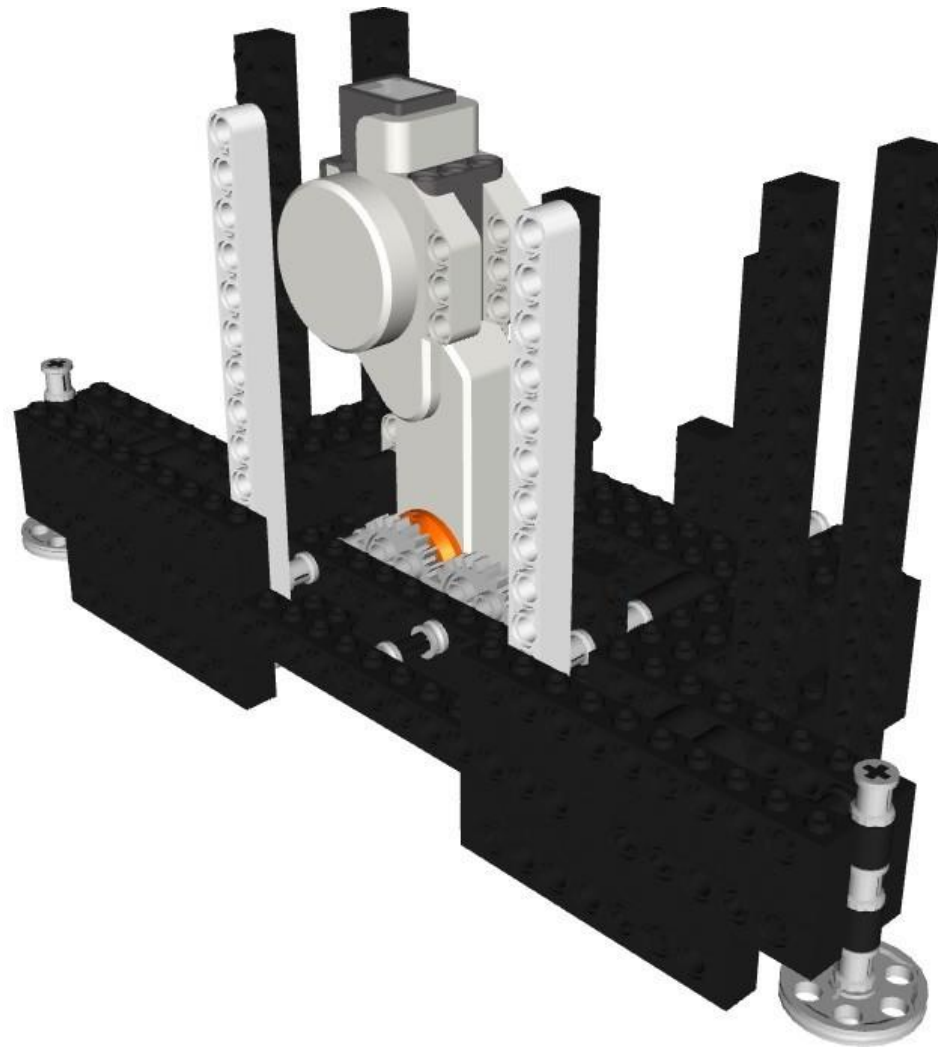

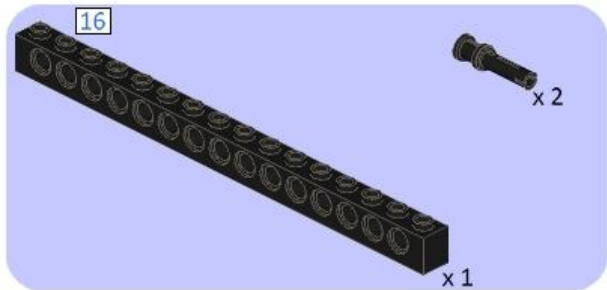
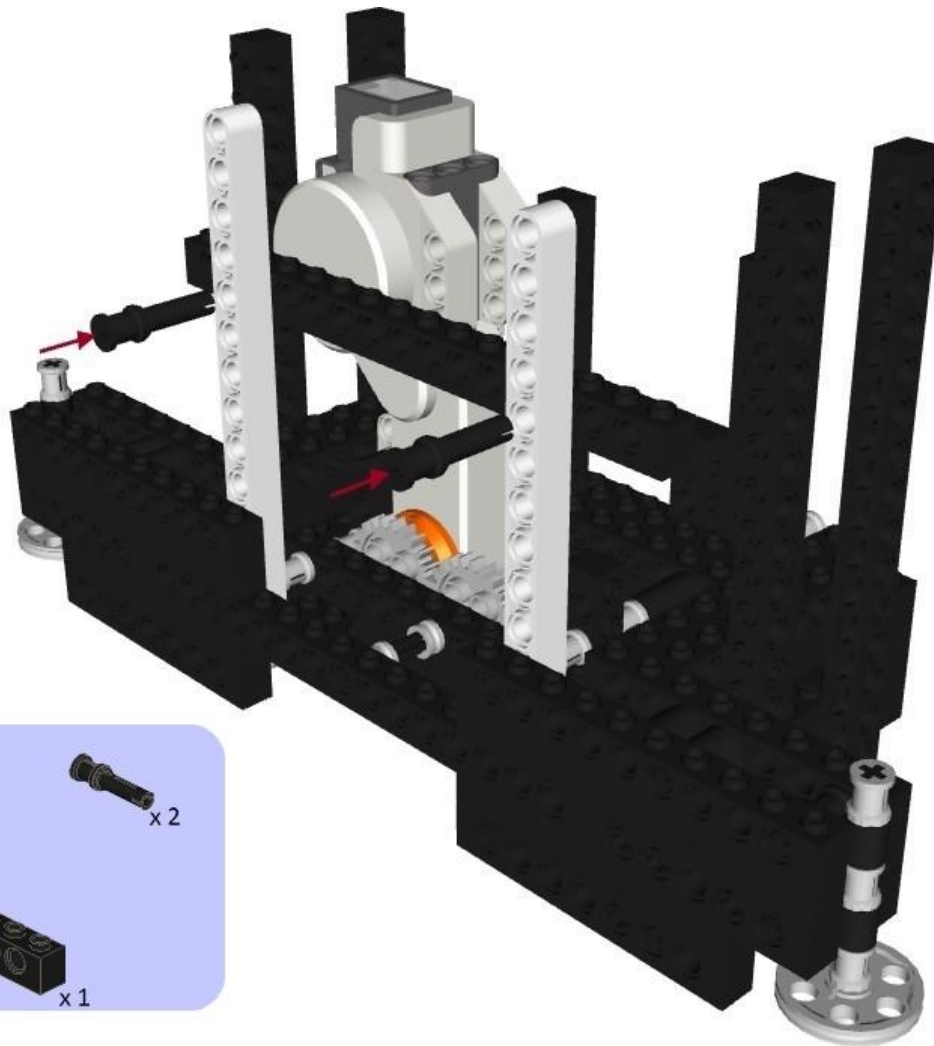

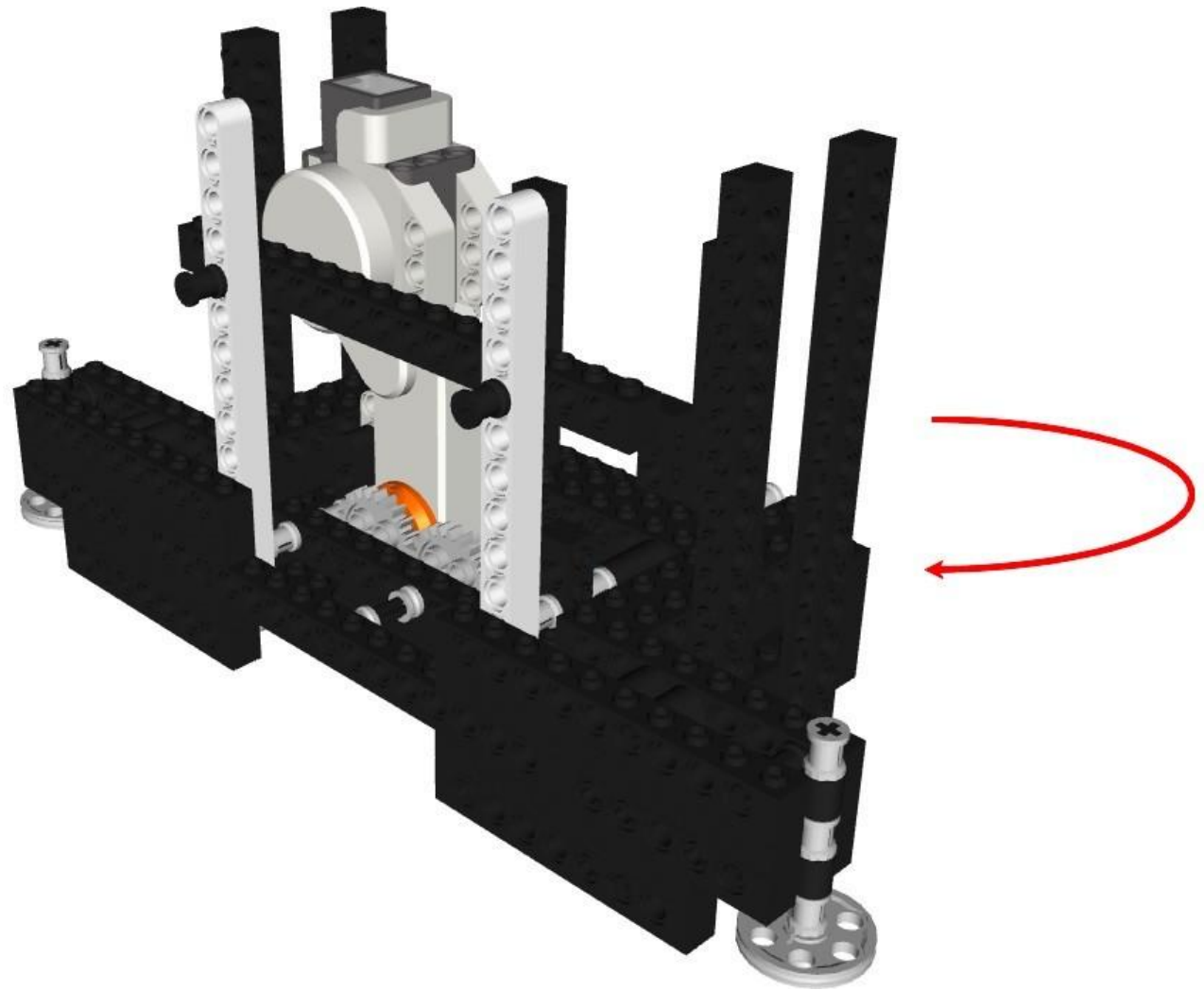

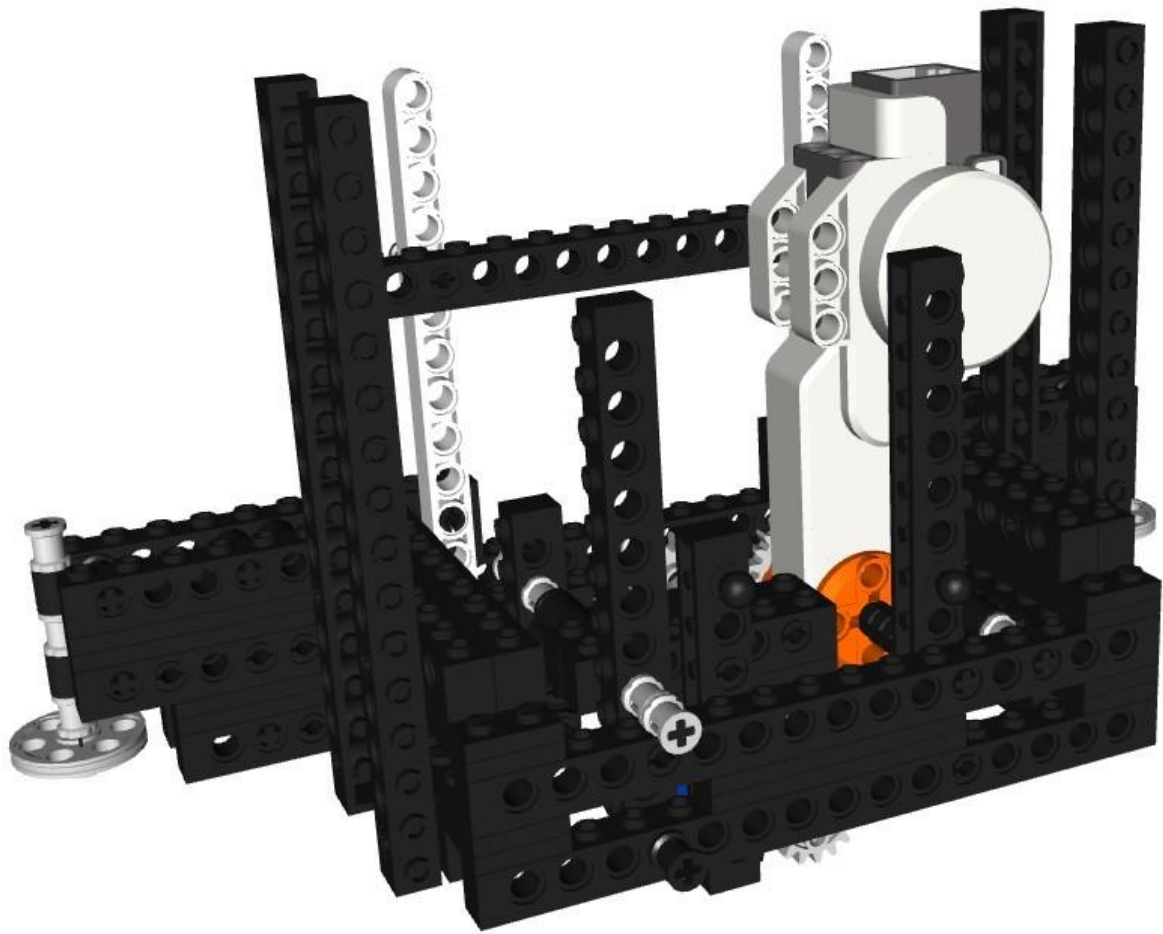

111/147

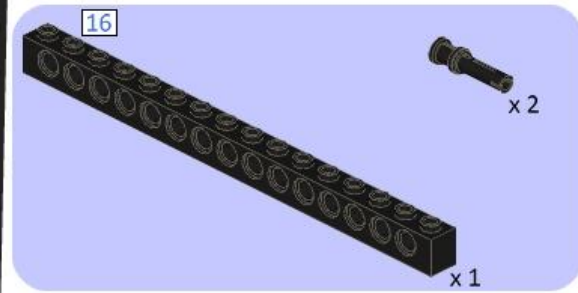
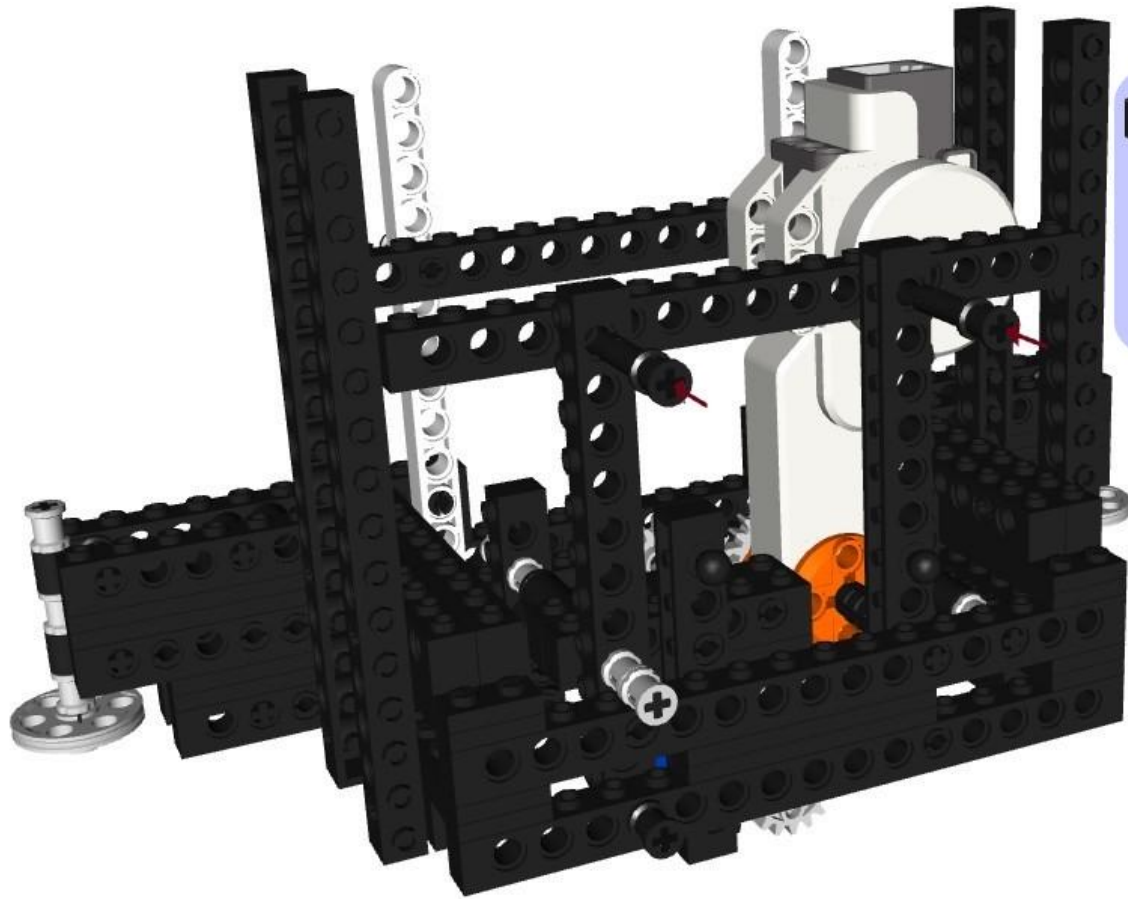

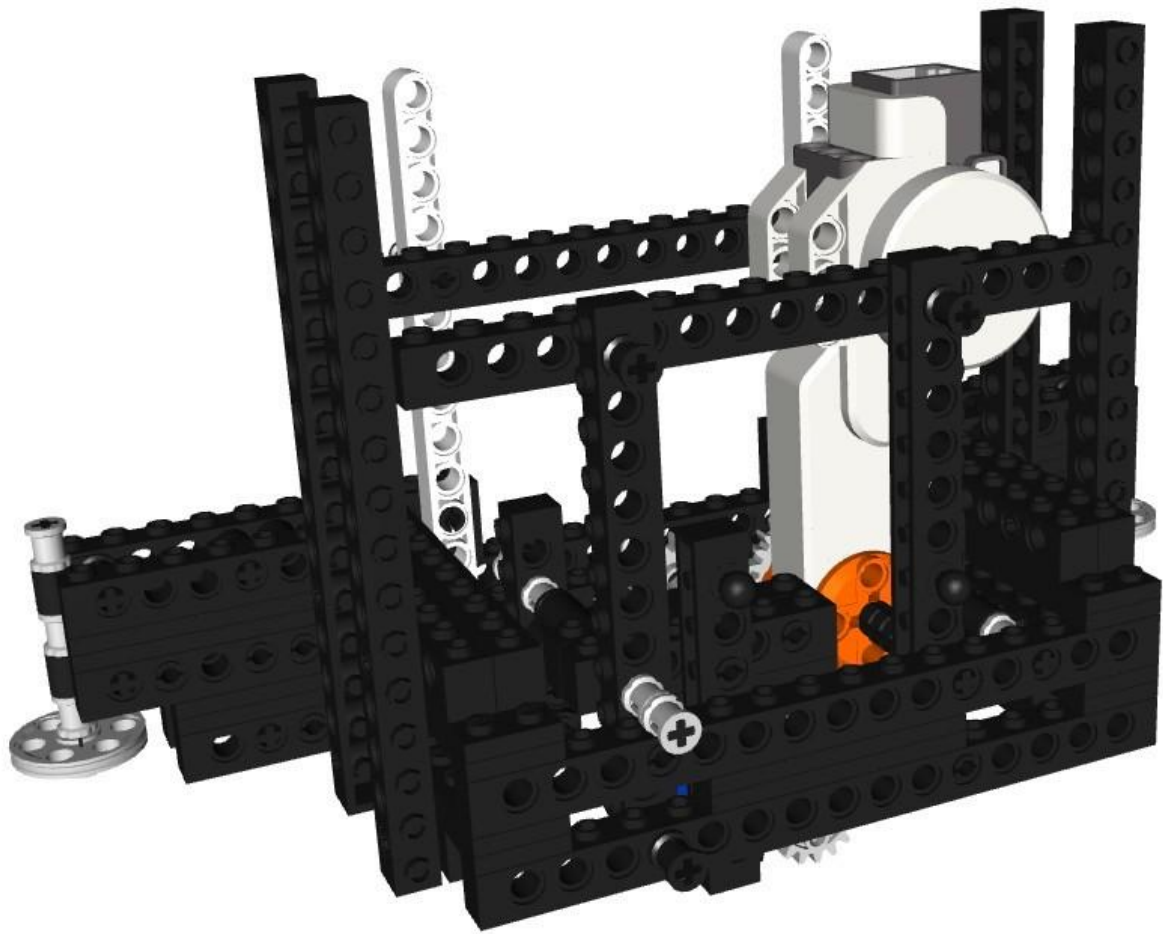

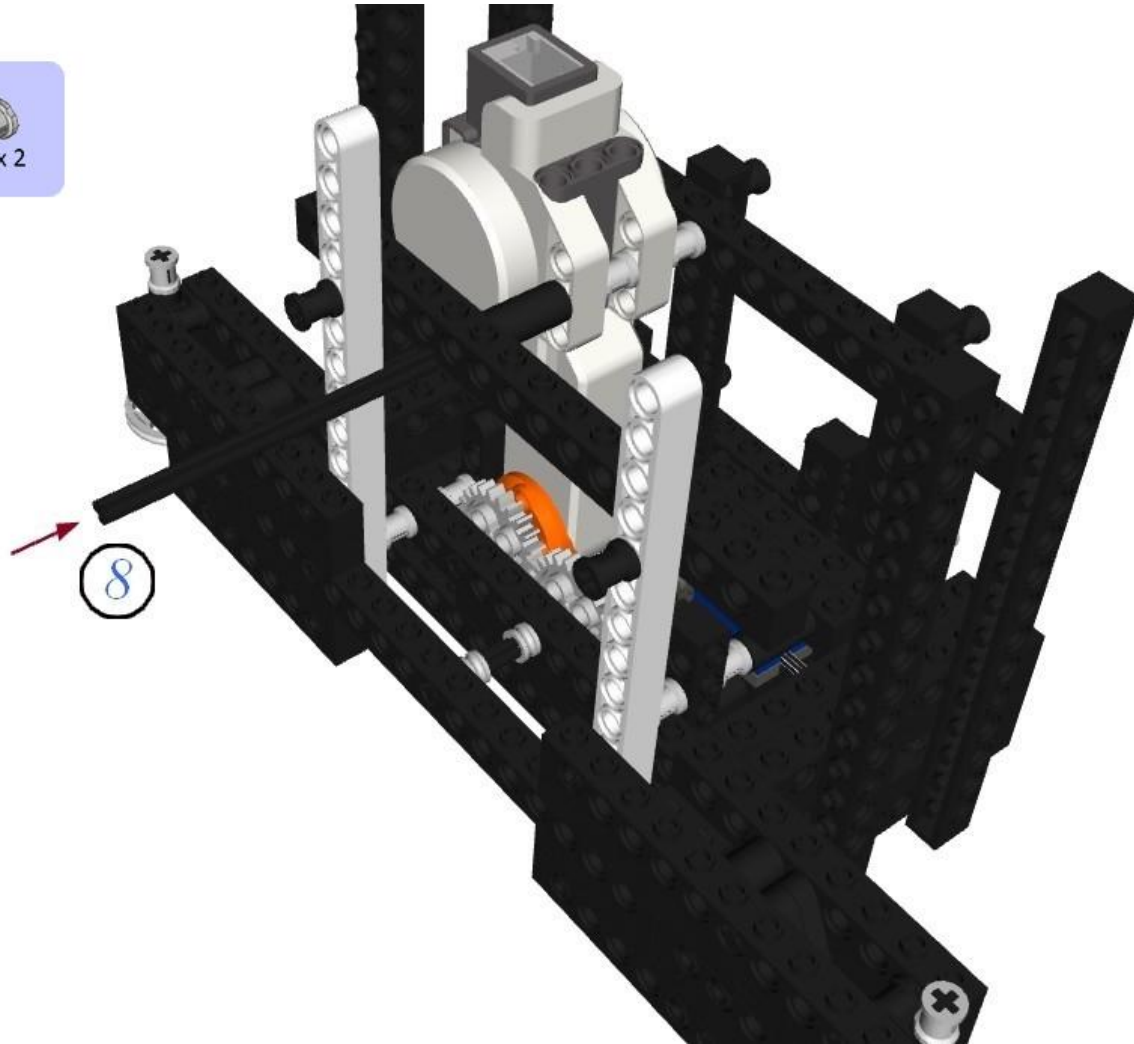

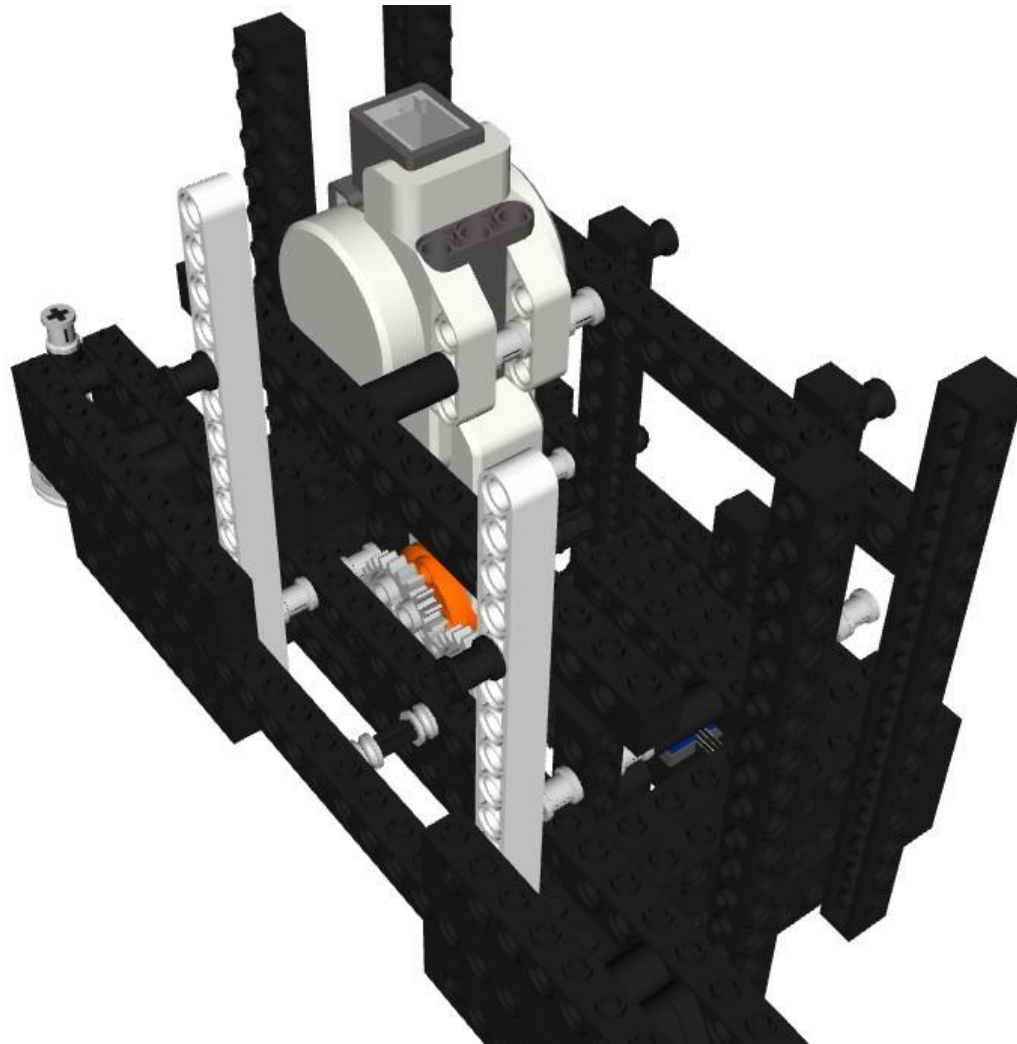

115/147

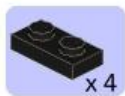

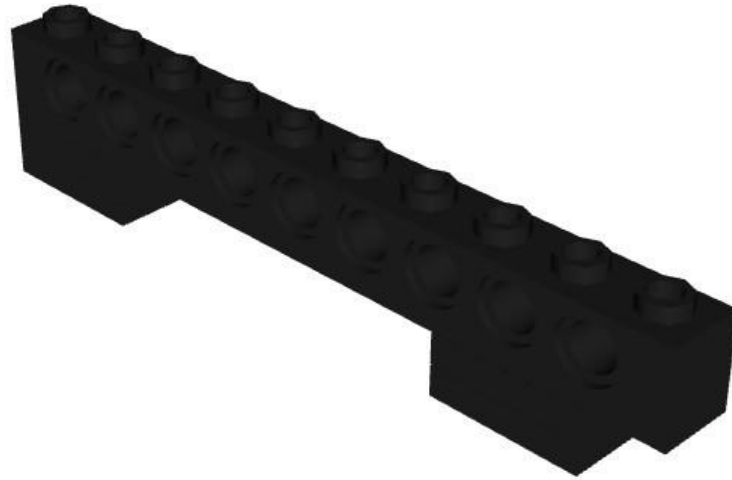
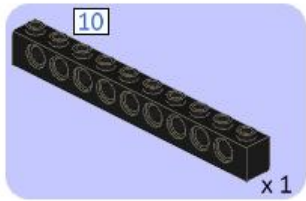

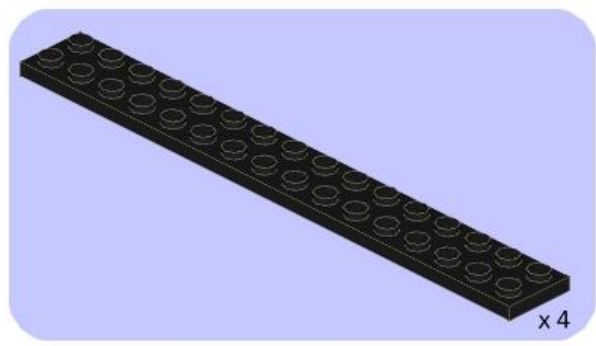
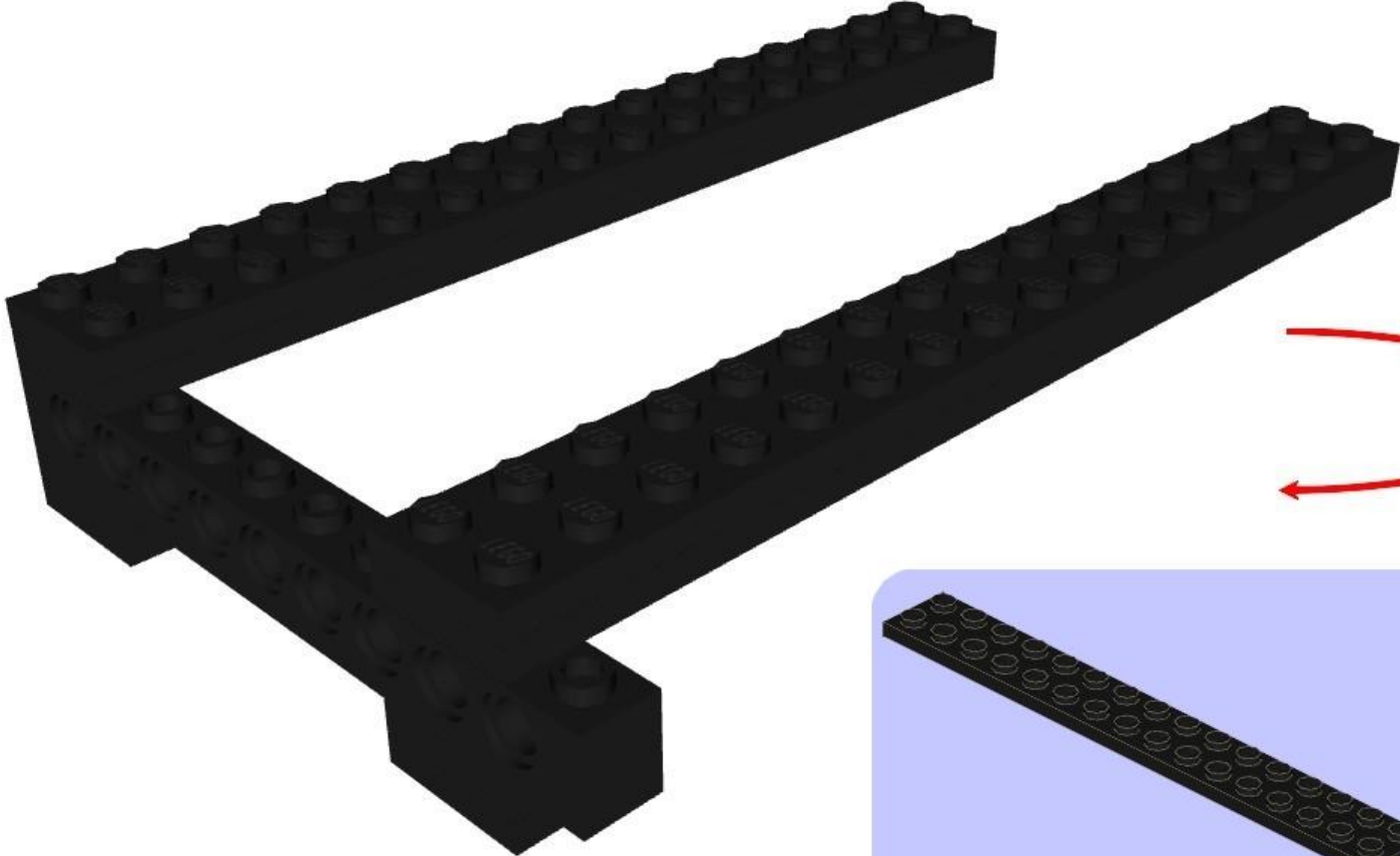

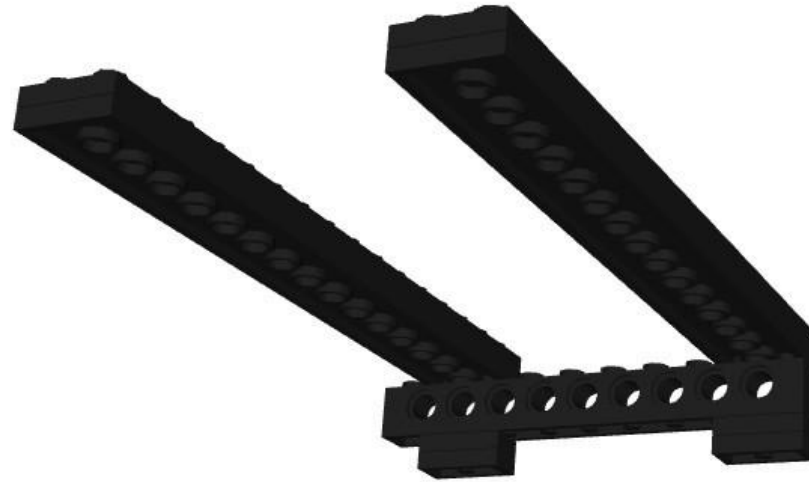

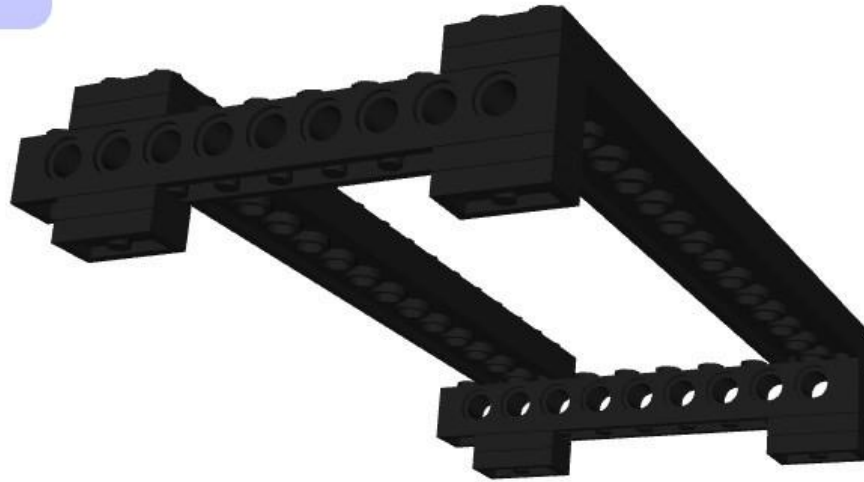
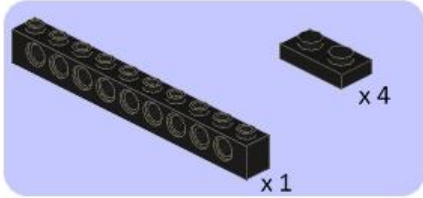

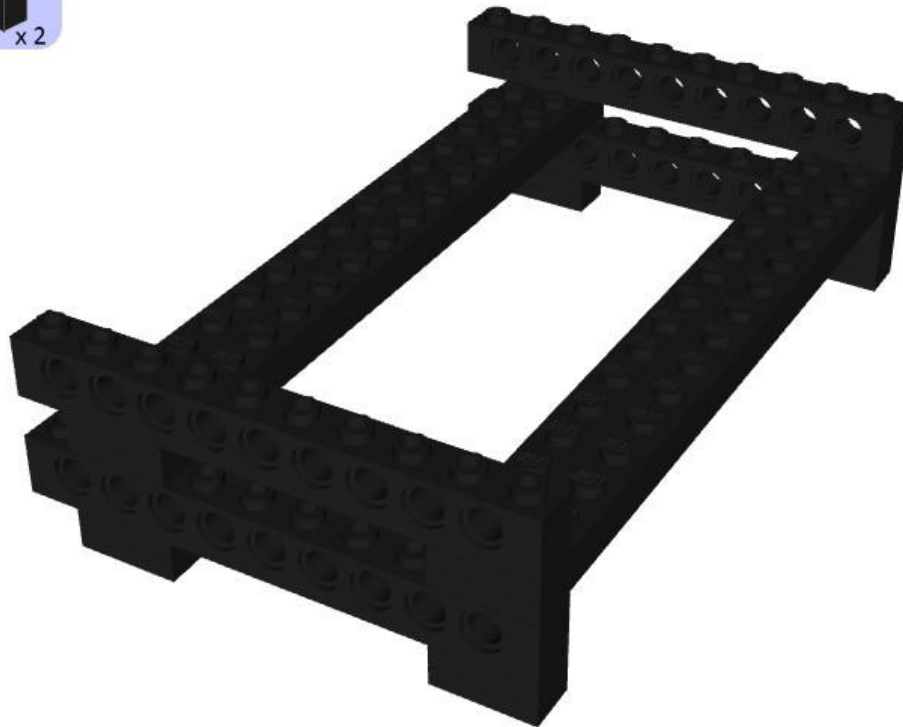

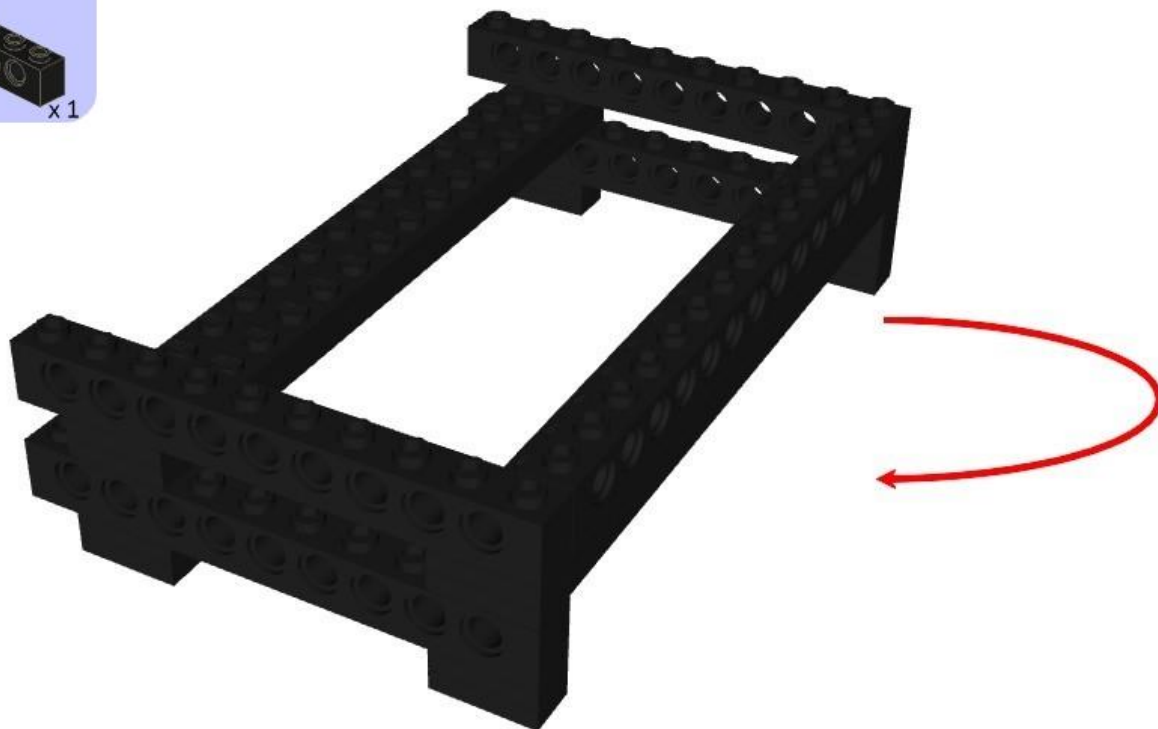
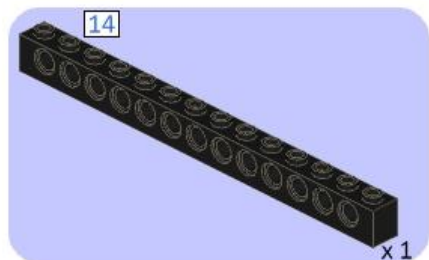



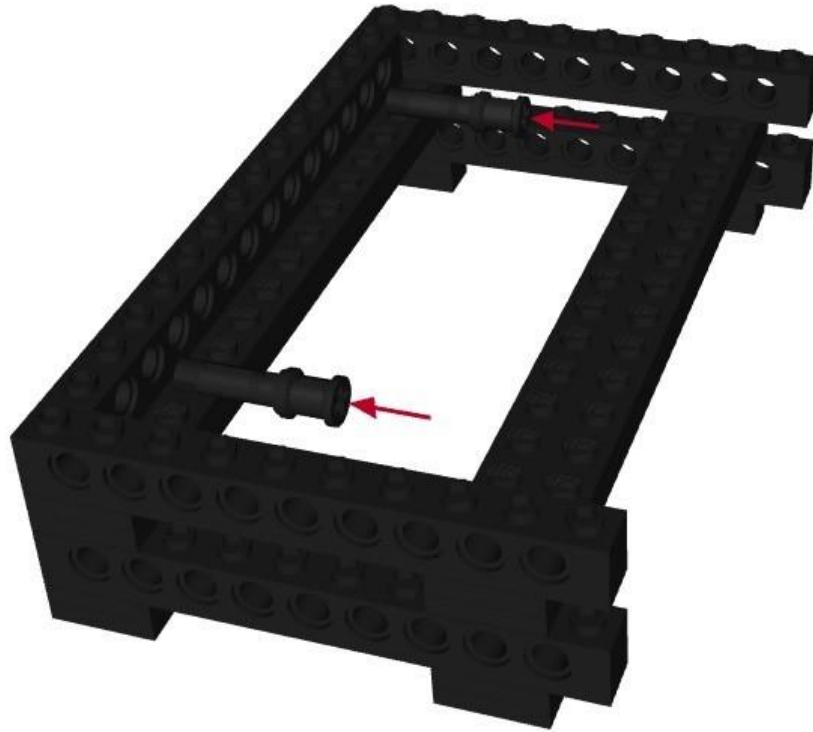

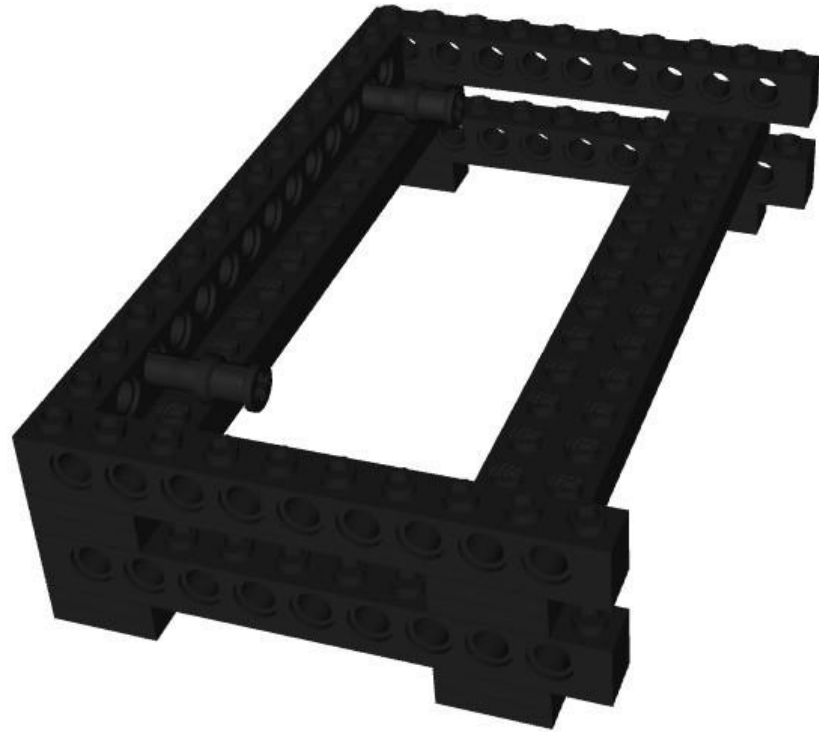

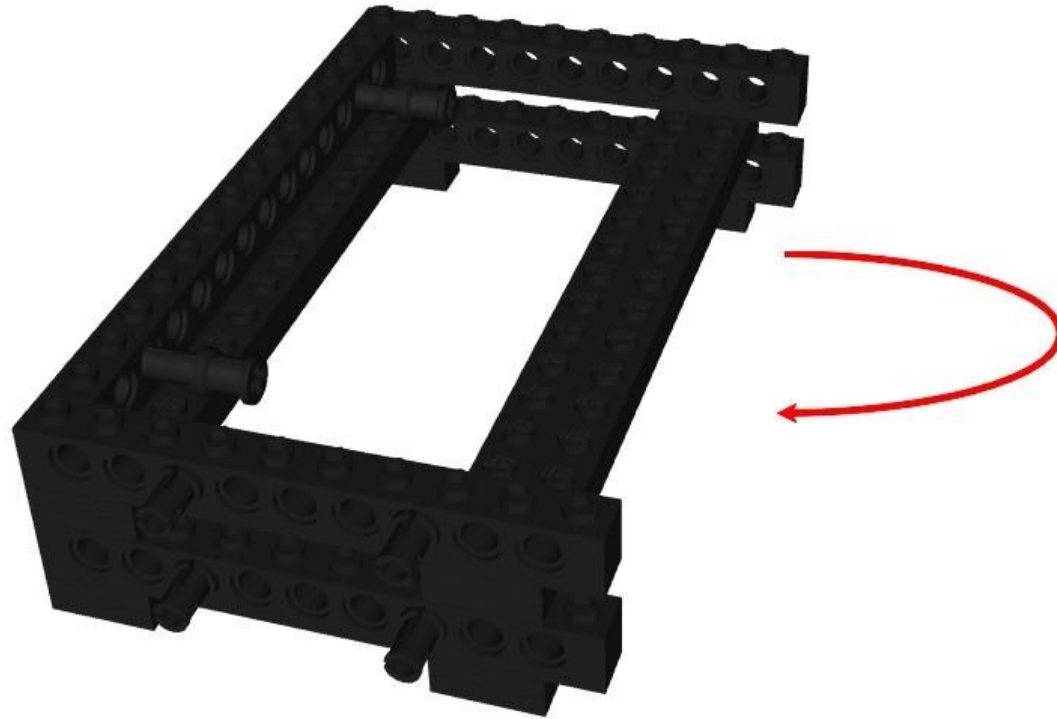

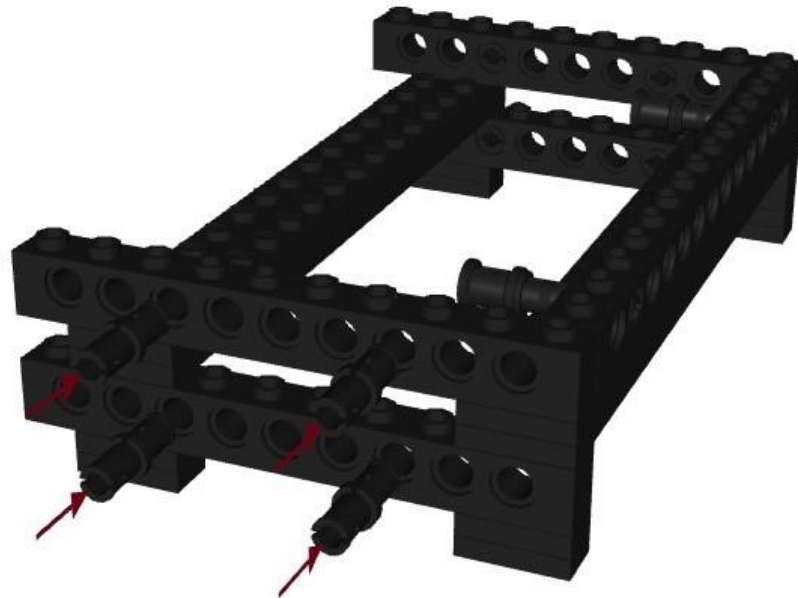

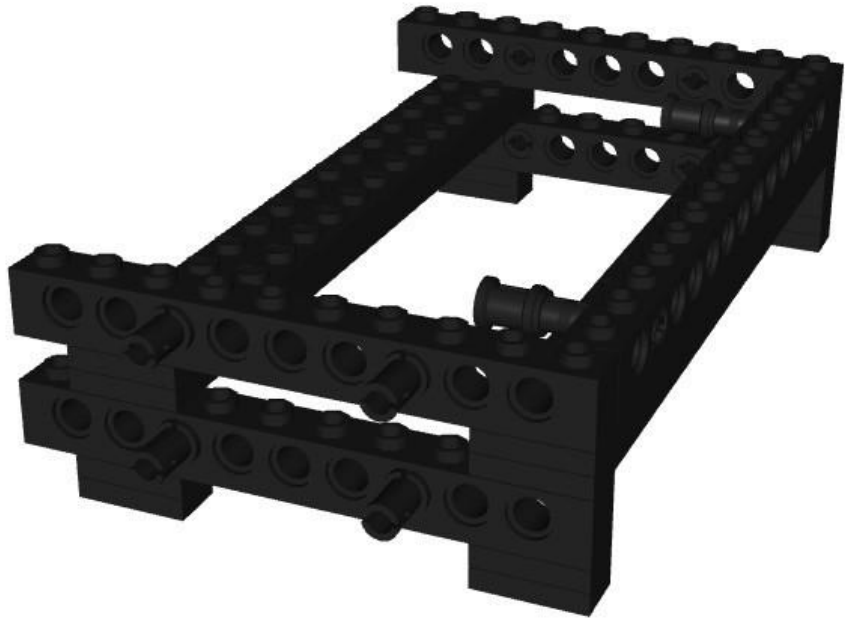

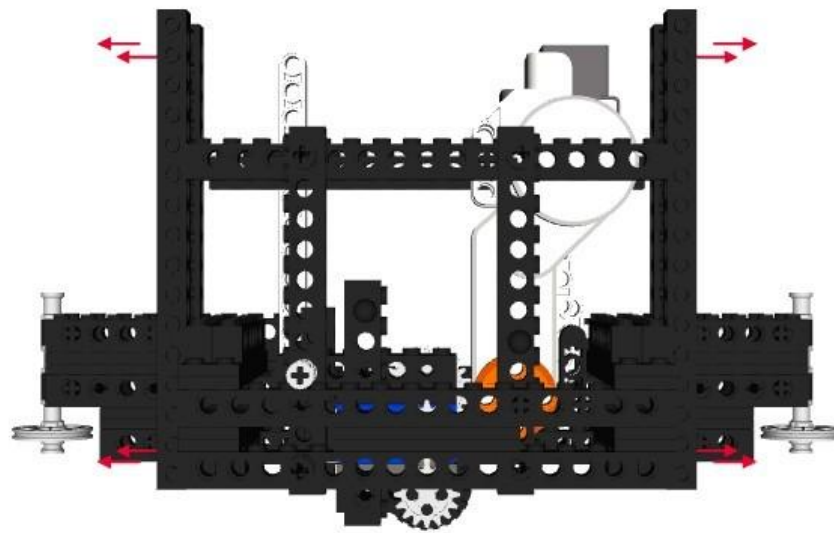

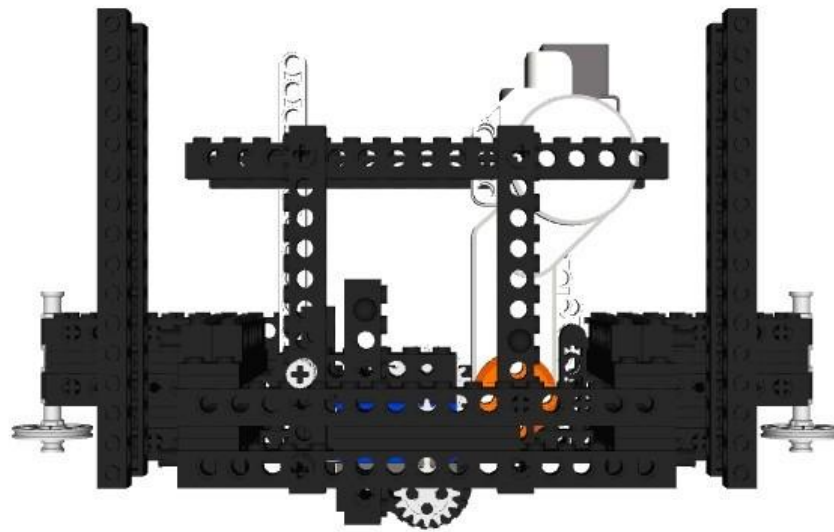

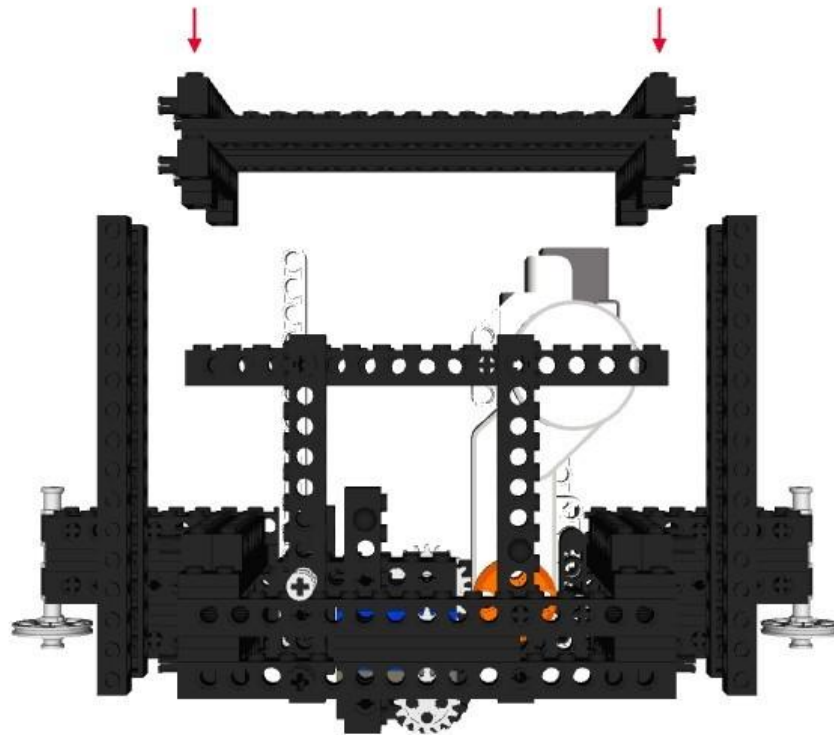

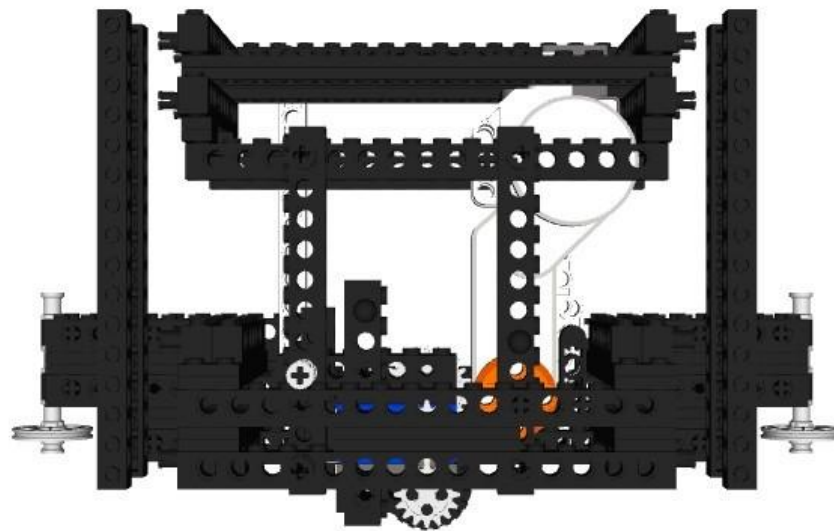

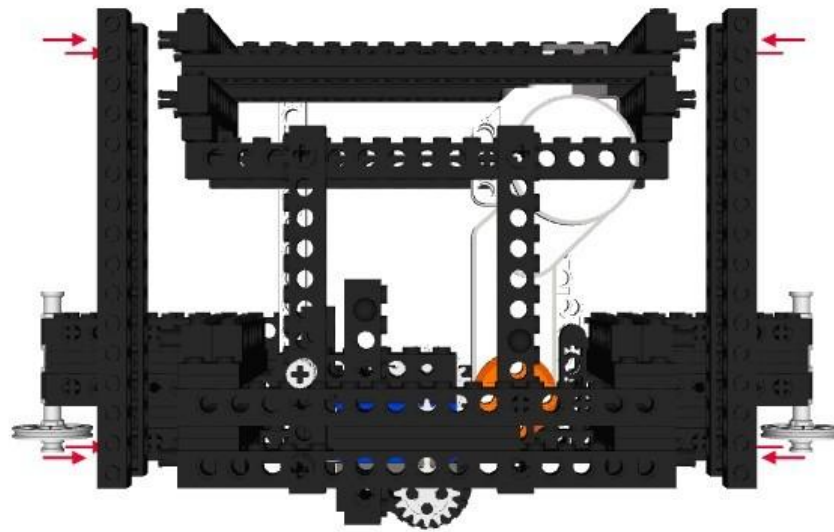

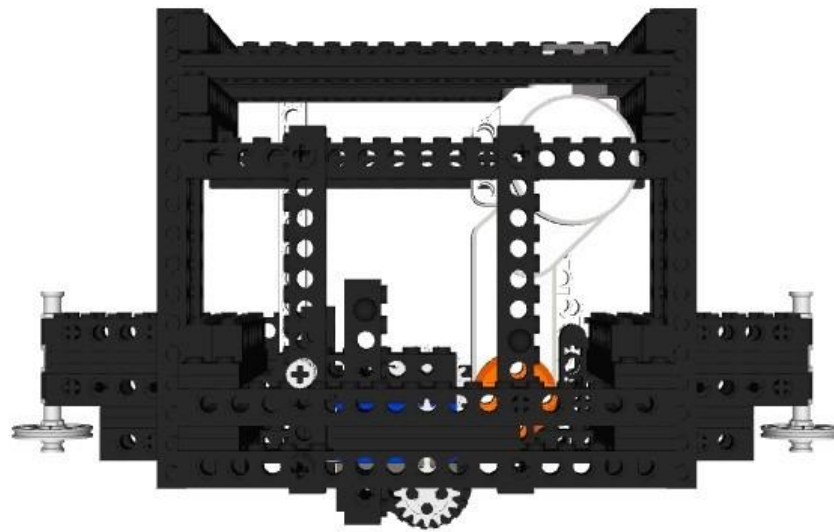

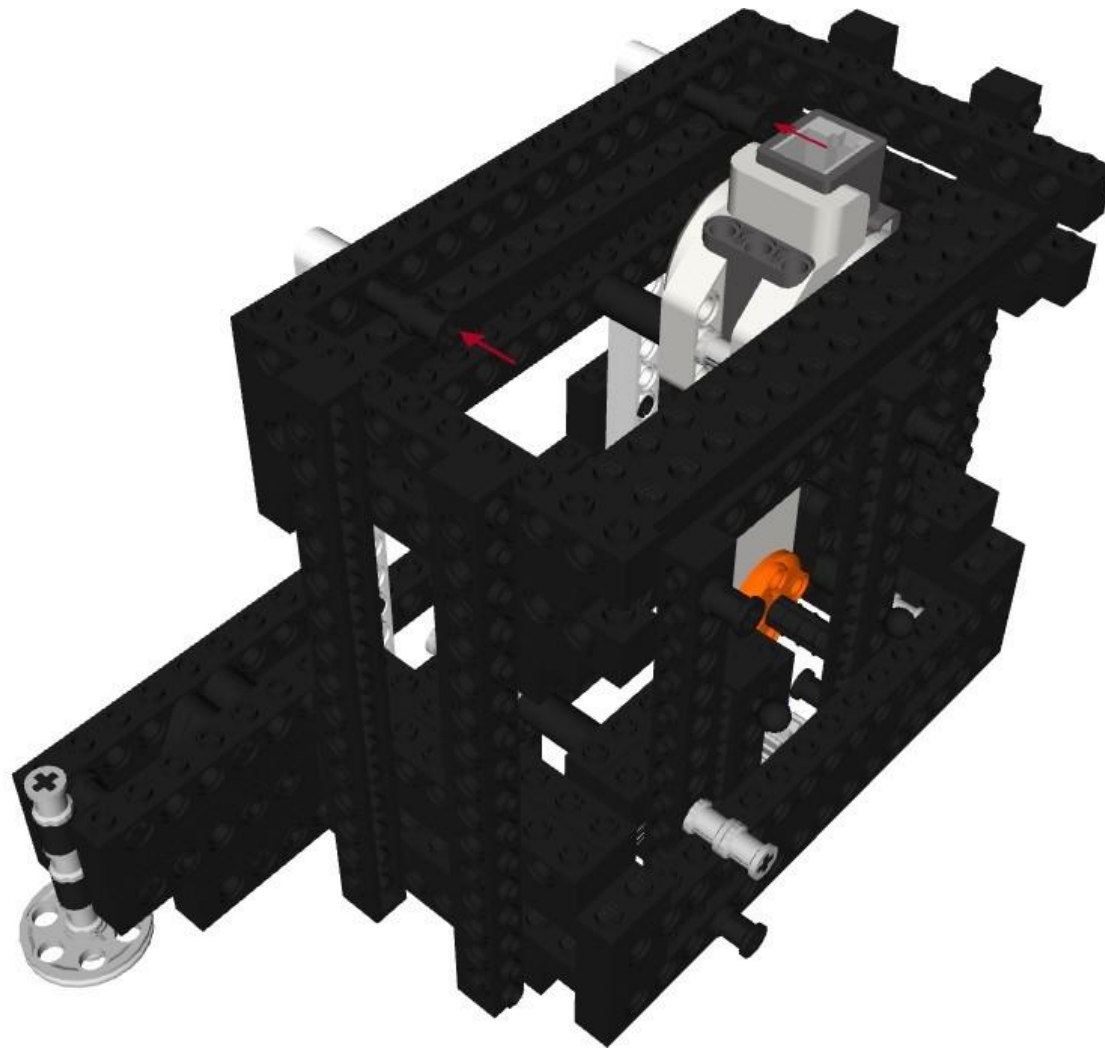

135/147

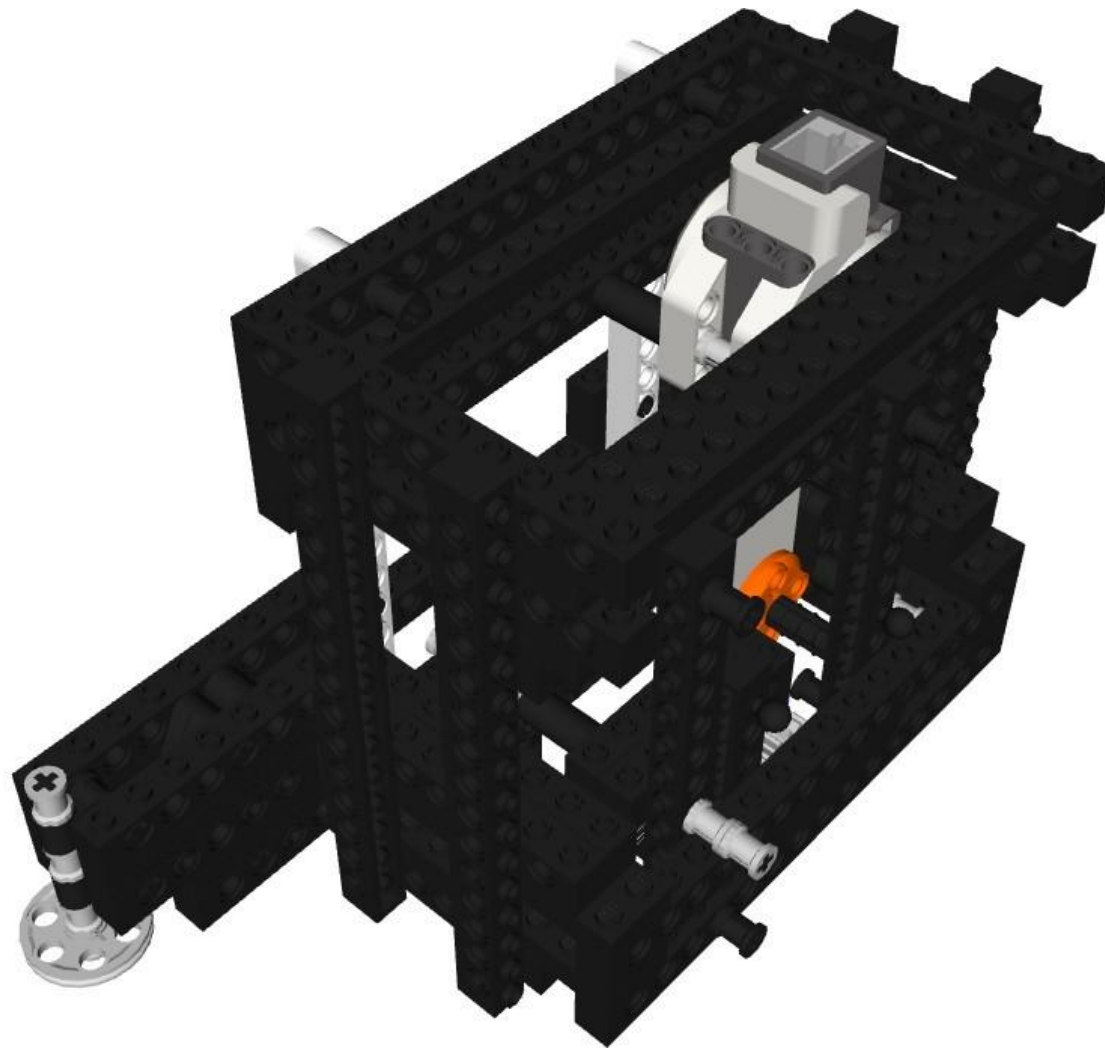

136/147

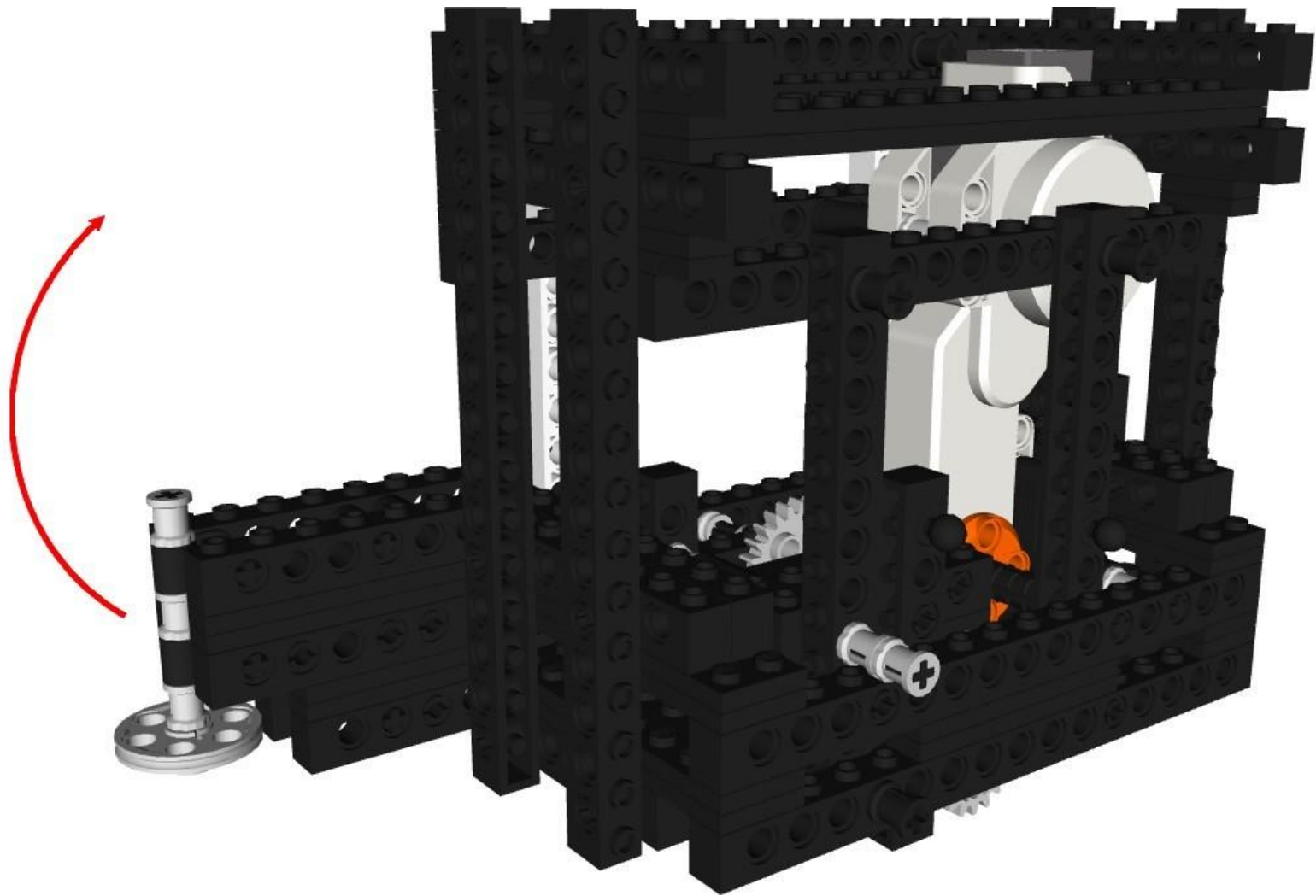

137/147

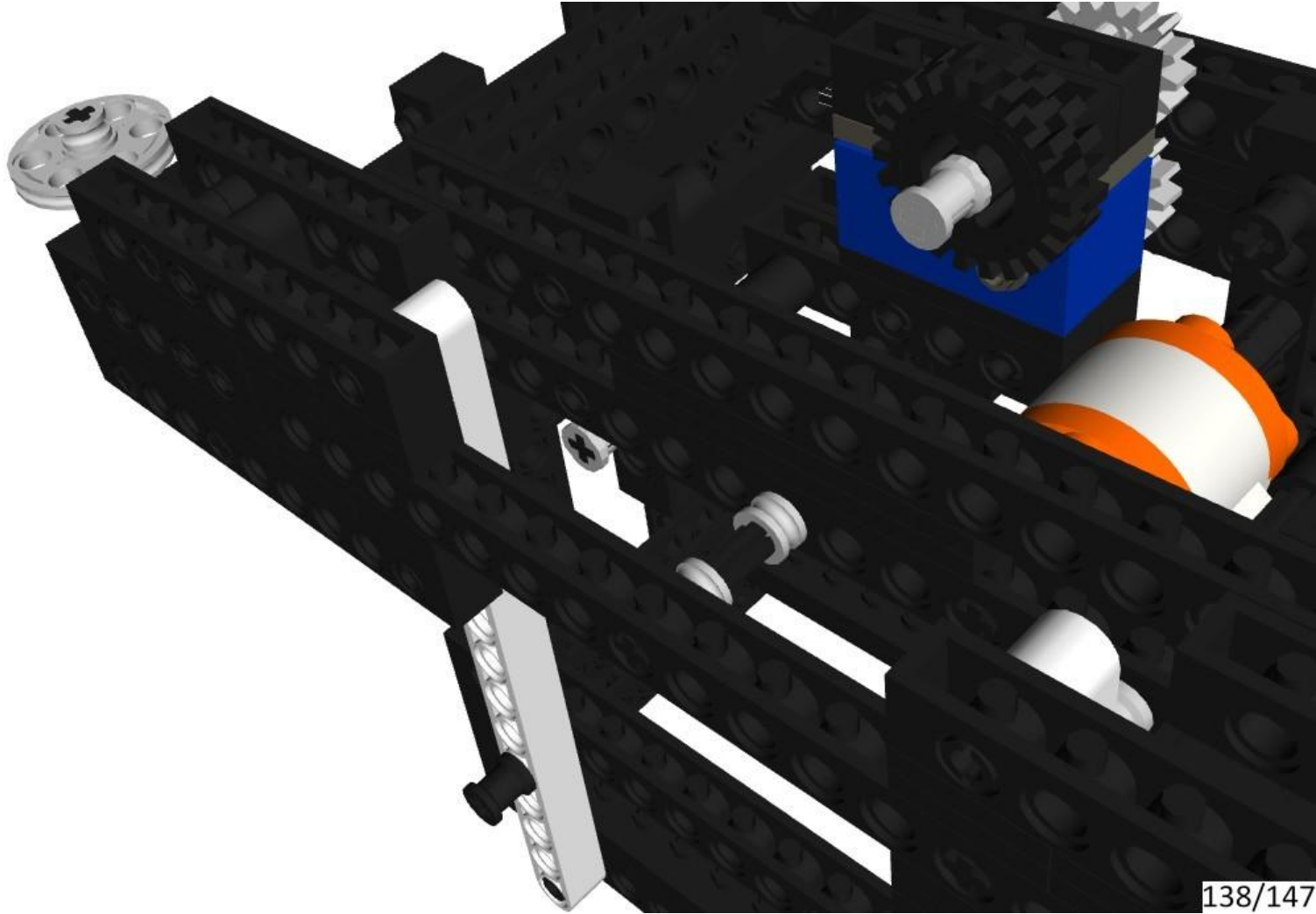

138/147

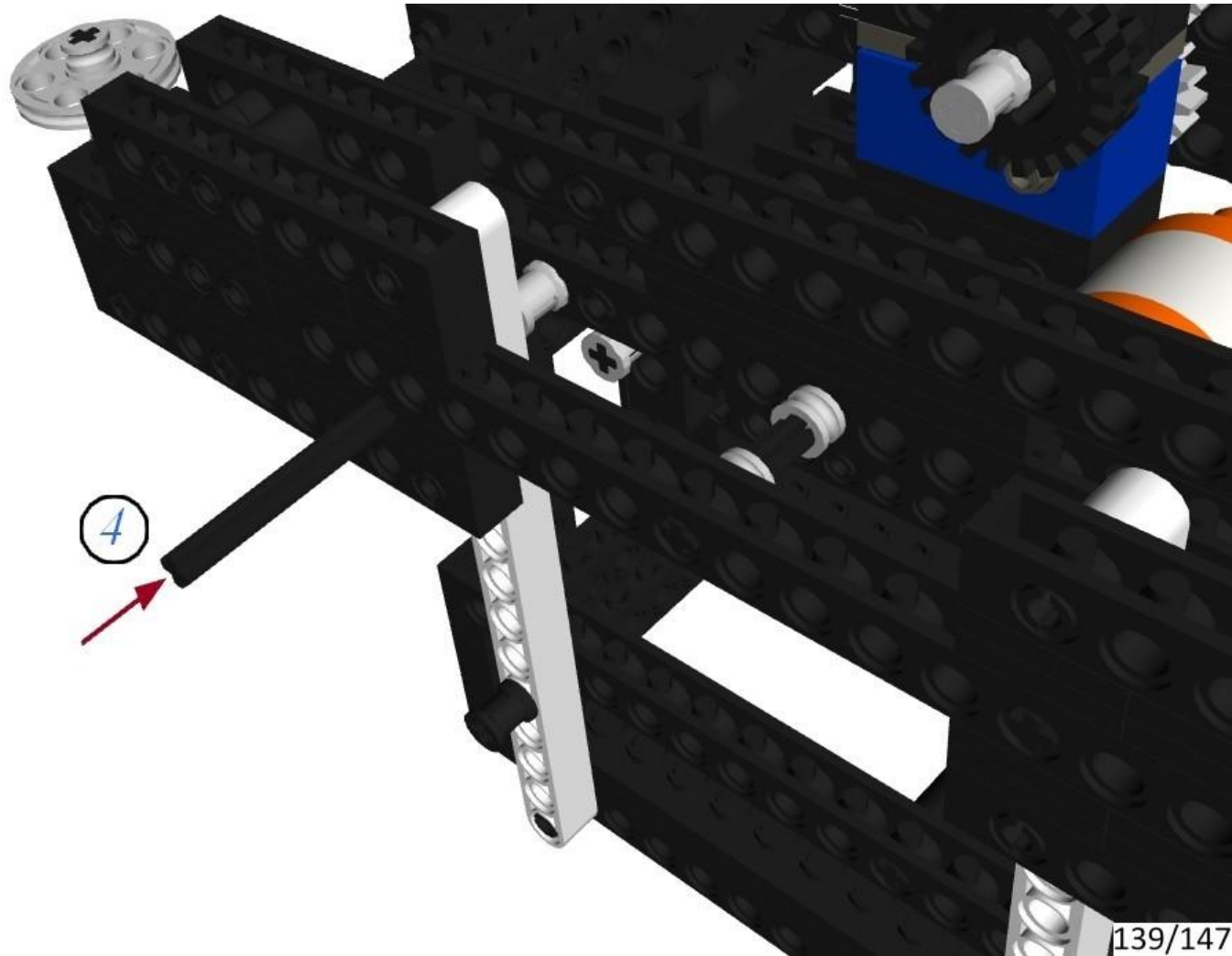
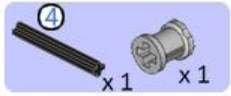

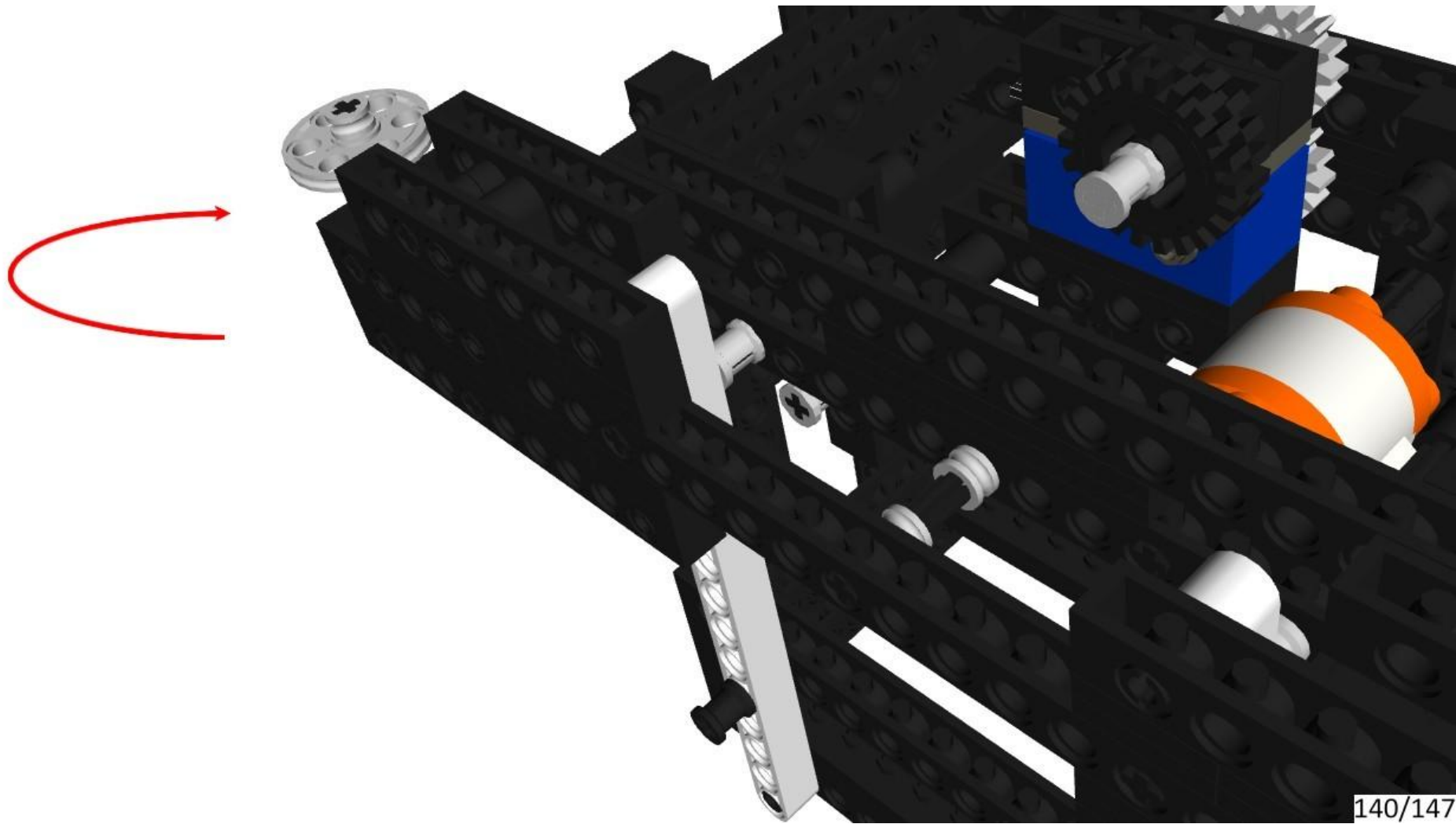

140/147

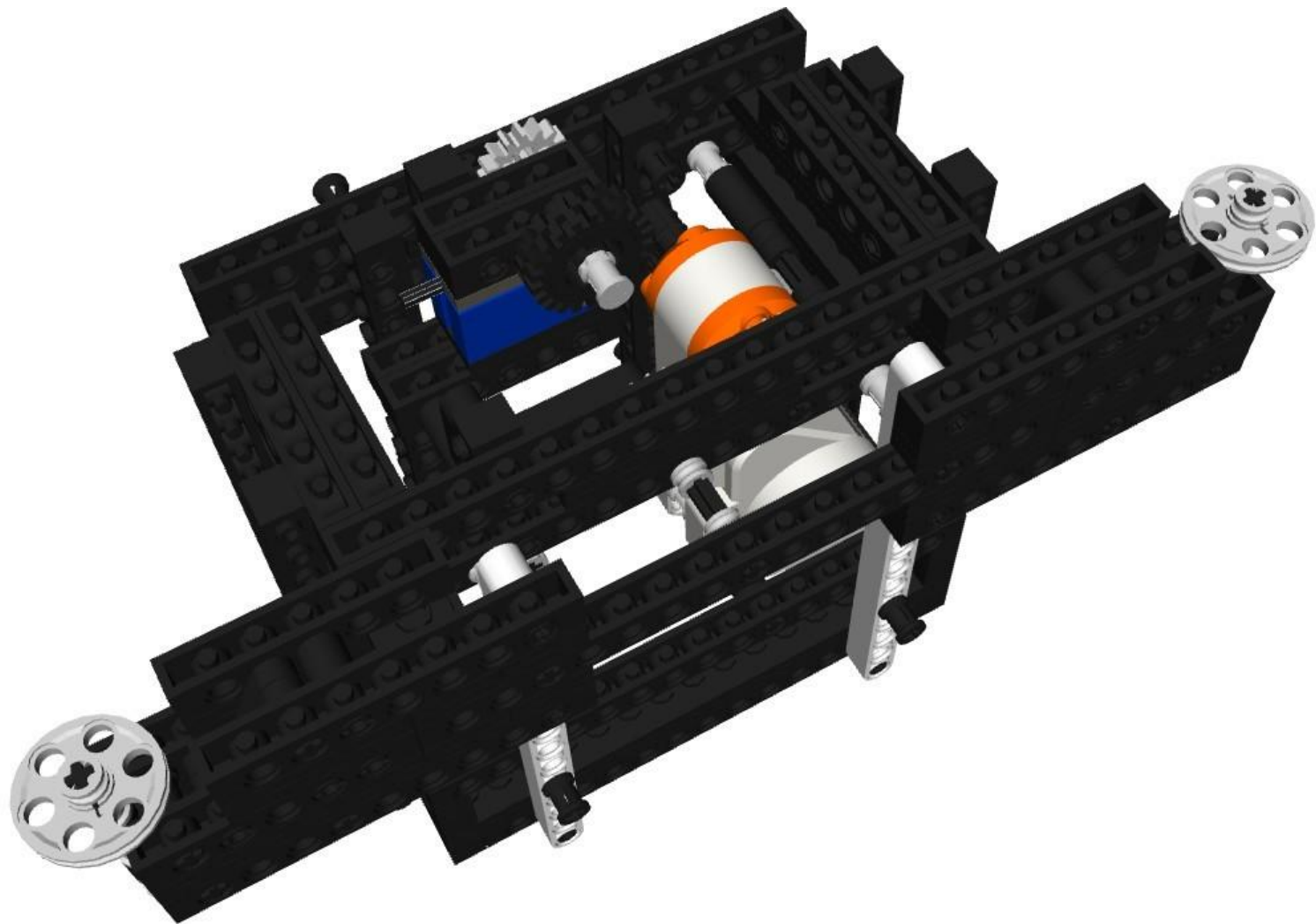

141/147

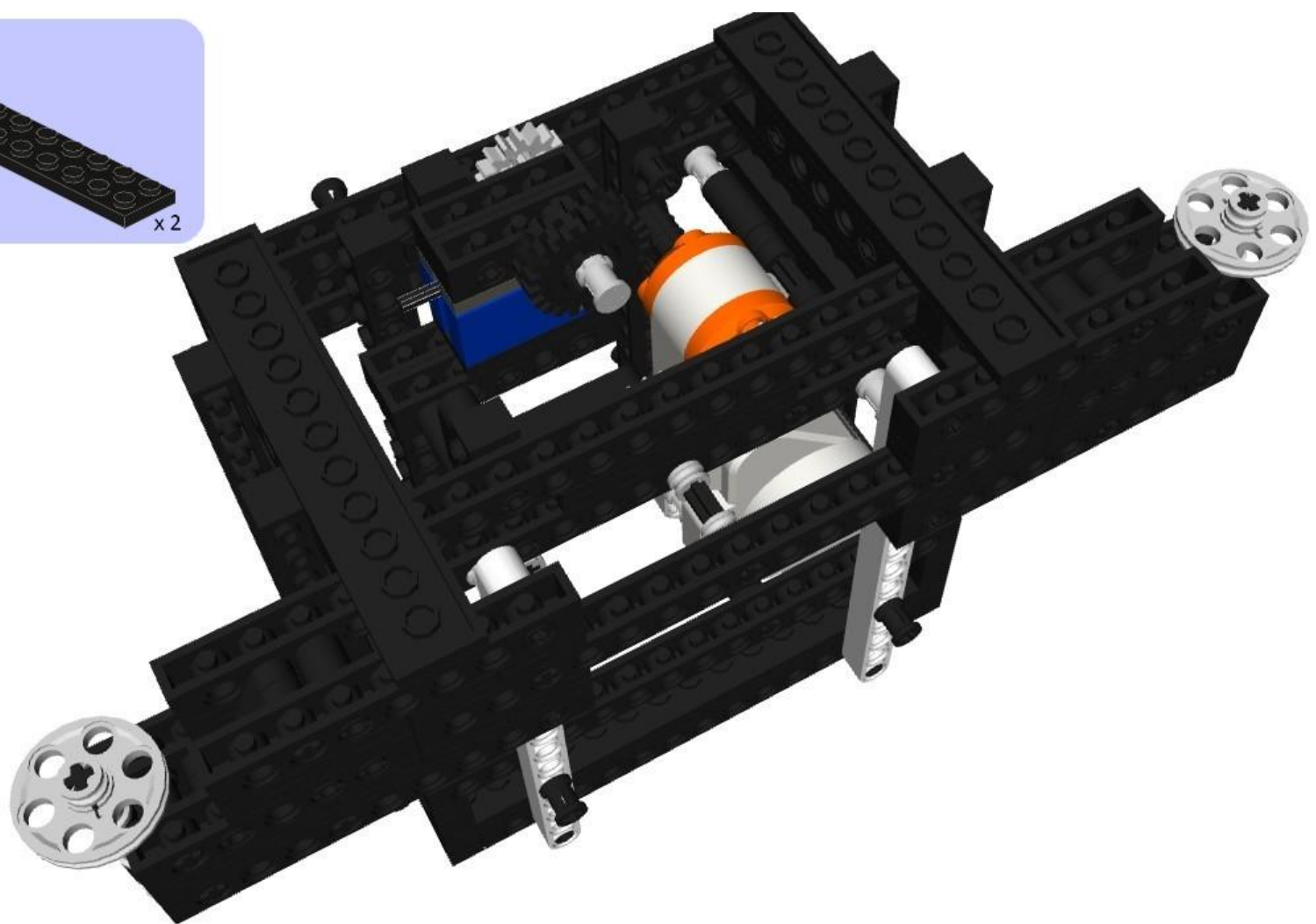
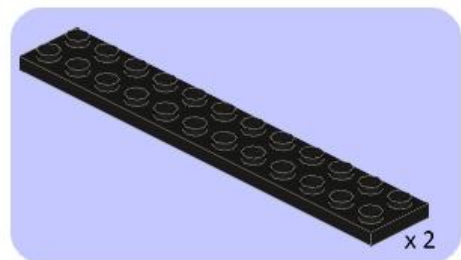

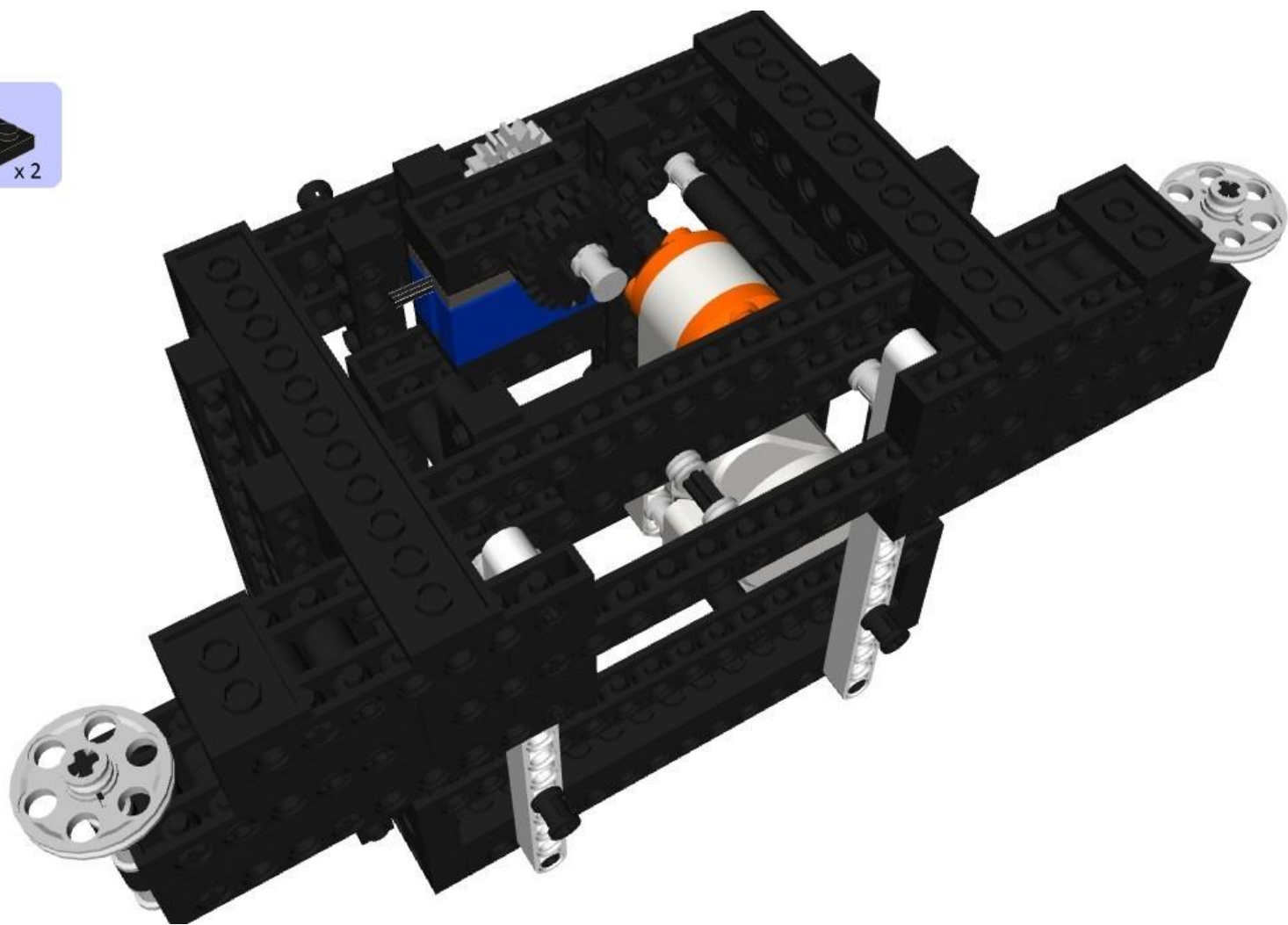
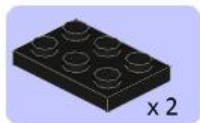

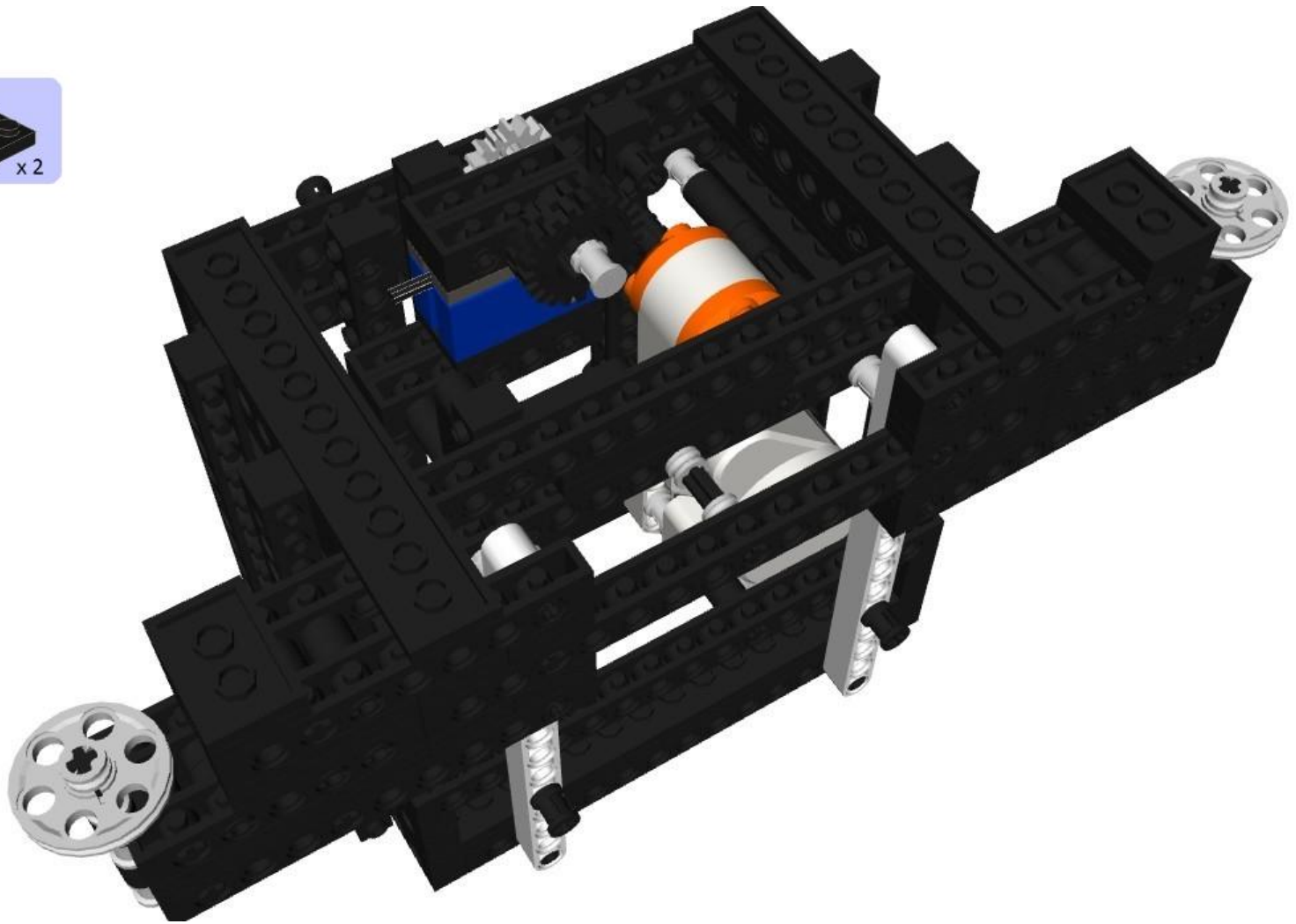
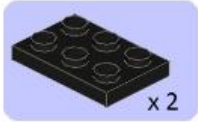

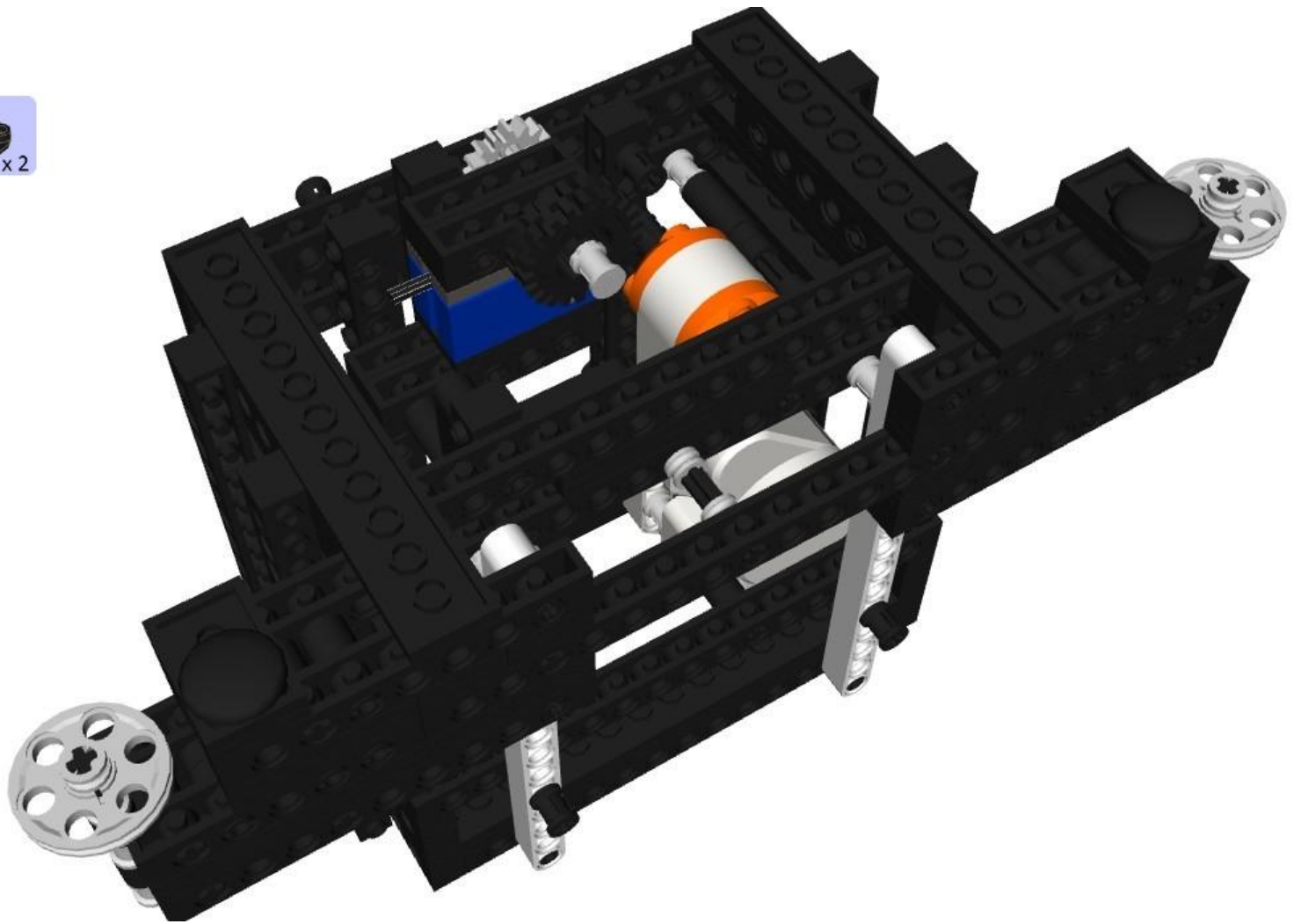

145/147

La base droite de votre robot est maintenant terminée.

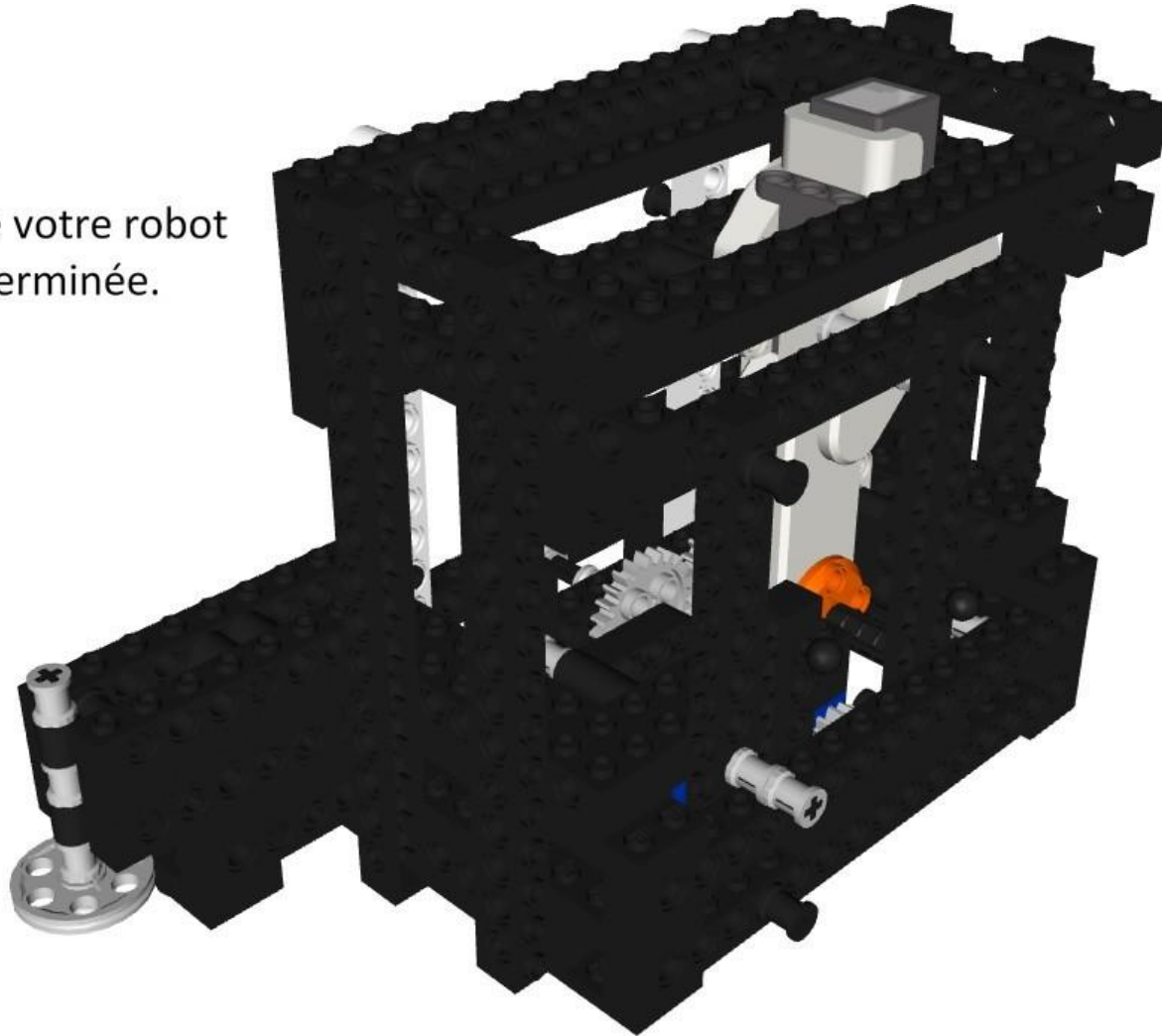

Pour terminer la base de votre robot, vous pouvez faire le symétrique de cette base par symétrie axiale. Pour assembler les deux parties, je vous conseille d'agrandir les pièces rouges des deux parties et de les attacher entre elles, par conséquent, il faudra changer la taille des pièces jaunes.

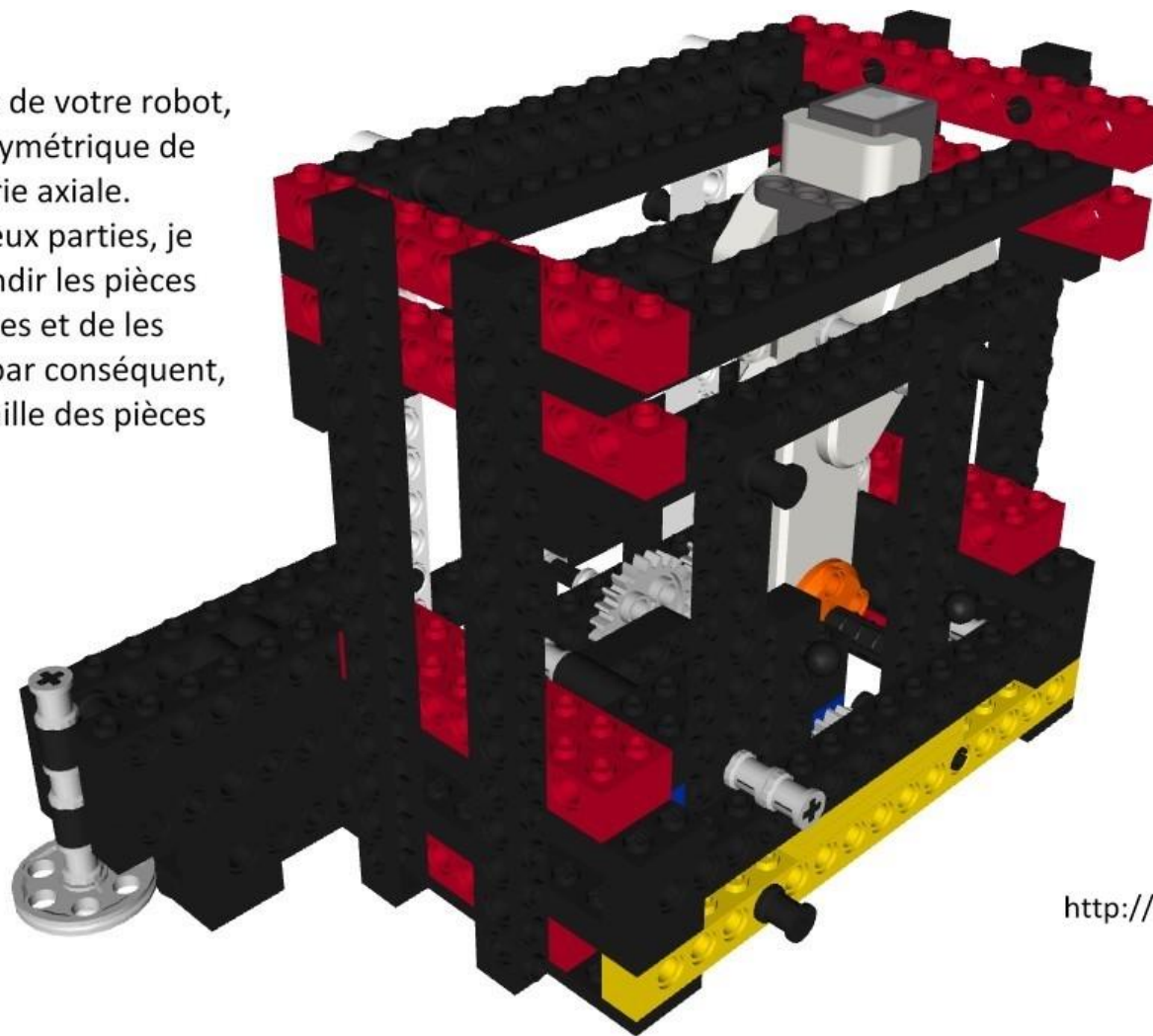

<http://www.perrinsteam.fr>

147/147